

Material Handling Machines

LH 40 Industry
Litronic®

LH 50 Industry
Litronic®

Operating Weight:
80,200 – 95,900 lb

Engine:
155 kW / 208 HP (SAE J1349)
155 kW / 211 HP (ISO 9249)

Stage Tier 4f

System Performance:
221 / 246 kW



LIEBHERR

LH 40 M Litronic Industry

Operating Weight:

80,200 – 85,300 lb*

Engine:

155 kW / 208 HP (SAE J1349)

155 kW / 211 HP (ISO 9249)

Stage Tier 4f

System Performance:

221 kW

LH 50 M Litronic Industry

Operating Weight:

82,900 – 90,200 lb*

Engine:

155 kW / 208 HP (SAE J1349)

155 kW / 211 HP (ISO 9249)

Stage Tier 4f

System Performance:

246 kW

LH 40 C Litronic Industry

Operating Weight:

88,200 – 95,900 lb*

Engine:

155 kW / 208 HP (SAE J1349)

155 kW / 211 HP (ISO 9249)

Stage Tier 4f

System Performance:

221 kW

Performance

Power plus speed –
Redefined performance



* Without working tool

Economy

Good investment –
Savings for long-term

Reliability

Durability and sustainability –
Quality down to the last detail

Comfort

Perfection at a glance –
When technology is comfortable

Maintainability

Efficiency bonus – Even with
maintenance and service



Performance



Power plus speed – Redefined performance

Liebherr has been designing and manufacturing successful machines for material handling for over 50 years. The new generation of Liebherr handlers, the LH 40 and LH 50 are high performance yet economical machines specially designed for using in scrap recycling, in timber yards and also for handling of bulk materials.

Maximum Handling Capacity

Increased Engine Output

Engine output has been increased from 140 kW to 155 kW compared to the predecessor models, giving the system more torque for more powerful and faster movement. Furthermore, load peaks are compensated cleverly, meaning maximum torque is available at all times for maximum handling capacity.

High Swing Torque

The separate hydraulic pump in the closed slewing circuit only supplies hydraulic fluid to the swing mechanism. The maximum delivery volume is thus available at any time for turning the uppercarriage for fast and dynamic rotational movements.

ERC System

The energy saved by lowering of the attachment in the ERC system is also available to the machine for the engine power, the resulting system performance for the material handling machines LH 40 and LH 50 is 221 kW respectively 246 kW. The result is more powerful, faster and more homogeneous operating cycles, which lead to increased handling capacity.

Precision Operation

LUDV Hydraulic System with Electrical Pilot Control

The new 2-circuit LUDV hydraulic system (flow distribution independent of load pressure) ensures faster working movements with up to 20% less fuel consumption in comparison to the predecessor models.

All work functions of the machine are controlled electrically, whereby the signals of the transmitters are only converted directly at the control block by hydraulic means. This technology enables end position damping of the attachment in order to protect the components and thus extend their service life. Simple, individual setting and adjustment of the working speed of boom, stick and slewing mechanism allow the driver to adjust the machine to each application and fully utilize the machine's capacity.

Firm and Stable Positioning

An essential prerequisite for precise working and maximum handling capacity is the firm and stable positioning of the machine. The design of the Liebherr undercarriage optimizes the way forces are induced on components and minimized stress. Together with the elaborate support geometry, maximum stability and durability are guaranteed.

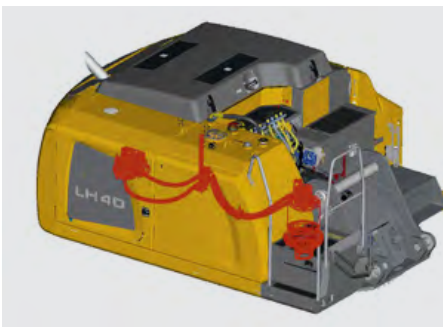

Liebherr Diesel Engine Compliant with Stage Tier 4f

- Powerful, robust and reliable
- Maximum torque even at low speeds to ensure fast movements with low fuel consumption
- Common rail injection system for maximum efficiency
- Emissions treatment with Liebherr SCR technology

Closed Slewing Circuit

- High torque for maximum acceleration and fast rotary movements
- Integrated speed sensor for controlling and monitoring braking movement for greater safety
- Greater fuel efficiency thanks to intelligent energy management in the closed system

Electrical Pilot Control

- Precision control irrespective of the ambient temperature for maximum precision
- Simpler and faster fault diagnostics for optimal availability
- Up to 5 individual driver profiles can be saved

Economy



Good investment – Savings for long-term

Liebherr material handling machines combine high productivity with excellent economy – all as standard. Liebherr manages to achieve this difficult goal through sophisticated engine technology from its own production and improved demand-controlled hydraulics.

Fuel Efficiency

Engine Idling and Engine Shut-down

The standard automatic idling function reduces the engine speed to idle as soon as the operator takes his hand from the joystick so that no hydraulic function is activated. Proximity sensors in the joystick levers restore the original engine speed as soon as the operator's hand is moved towards the lever again. This ensures that the set engine speed is available immediately. The result is a combination of fuel saving and reduced noise levels. Operating costs can be reduced even further with the optional automatic engine shut-down function.

Closed Hydraulic Circuit for the Swing Mechanism

The closed slewing circuit feeds the braking energy back into the system when the uppercarriage is braked. Here, new standards are set in terms of efficiency and economy. Simple yet effective.

Increased Productivity

ERC System

The ERC system not only brings about an enormous increase in performance and a higher handling capacity, but it also generates fuel savings of up to 30 %, lower operating costs, as well as reduced pollutant and noise emissions.

Efficient Management

LiDAT, Liebherr's own data transmission and positioning system, facilitates efficient management, monitoring and control of the entire fleet park in terms of machinery data recording, data analysis, fleet park management and service. All of the important machinery data can be viewed at any time in a web browser. LiDAT offers you comprehensive work deployment documentation, greater availability thanks to shorter downtimes, faster support from the manufacturer, quicker detection of strain/overload and subsequently a longer service life of the machine as well as greater planning efficiency in your company. This service includes 1 year of use without charge as standard for the material handlers LH 40 and LH 50.

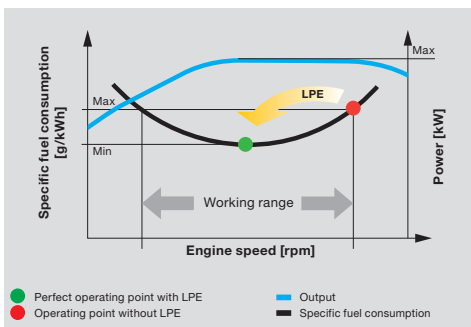

Low Fuel Consumption Thanks to Intelligent Machine Control

- Liebherr-Power Efficiency (LPE) optimizes the interaction of the drive components in terms of efficiency
- LPE enables machine operation in the area of the lowest specific fuel use for less consumption and greater efficiency with the same performance

Liebherr-Working Tools

- Robust and service-friendly slewing drive, can be turned 360°
- Optimum filling and clamping performance for effective material handling
- Finite element method (FEM) optimized for a perfect relationship between grapple weight, volume and a very long service life

ERC System

- Increased total power
- Higher handling capacity
- Fuel savings of up to 30 %
- Lower running costs
- Reduced pollutant and noise emissions

Reliability



Durability and sustainability – Quality down to the last detail

Every day Liebherr material handlers show their qualities in a very wide range of industrial applications all over the world. Years of experience, continuous development and the latest technologies provide maximum safety in use. Their robust design and the use of components produced in-house ensure that the material handling machines LH 40 and LH 50 are designed for a long service life.

More Safety

Pipe Fracture Safety Valves

The standard pipe fracture safety valves on the stick and hoist cylinders prevents the attachments from dropping in an unregulated way and ensure maximum safety during every operation.

Working Range Limiters

For operations in which the working range should be limited, the material handling machines can be equipped optional with a working range limitation feature. Hereby all types of dimensions can be set: height, depth, width and proximity. Collisions and resulting component damage can thus be avoided.

Overload Warning Device and Load Torque Limitation

The acoustic and visual overload warning system continuously tells the operator about the current load situation of the machine. Furthermore, load torque limitation automatically regulates the speed of the working hydraulics to allow the maximum load bearing capacity to be approached safely. In the event of an overload, the functions which could cause the machine to topple are disabled. Only movements back to the safe working range are then possible.

High Machine Availability

Quality and Competence

Our experience, understanding of customer needs and the technical implementation of these findings guarantee the success of the product. For decades, Liebherr has been inspirational with its depth of production and system solutions. Key components such as the diesel engine, electronic components, slewing ring, swivelling drive and hydraulic cylinders are developed and produced by Liebherr itself. The great depth of in-house manufacturing guarantees maximum quality and ensures that components are optimally configured to each other.

Robust Design

All steel components are designed and manufactured by Liebherr itself. High-strength steel plates configured for the toughest of requirements result in high torsional stiffness and optimum absorption of forces induced for a longer service life.

Intelligent Self Diagnostics

The clever control electronics permanently monitor the vital functions of the machine to guarantee a high level of machine availability. Components which are critical for safety are designed with redundancy to guarantee maximum reliability.



QPDM – Quality and Process Data Management

- QPDM allows production data to be logged, documented and evaluated
- Automation of documentation and test specifications
- Ability to handle large quantities with maintain uniform high quality

Piston Rod Protection

- Maximum protection of piston rod
- Robust construction of hot-dip galvanized steel for a long service life in tough applications
- Available for outriggers, hoist cylinders, ERC cylinder and tip cylinder as an option

Attachment

- Components enhanced using FEM for maximum service life even if subjected to heavy lateral stresses during demanding tasks
- Cables routed internally to protect them from damage
- High load capacities with long reaches
- Reaches up to 19 m

Comfort



Perfection at a glance – When technology is comfortable

The newly designed operator's work station sets new standards in comfort. The Liebherr deluxe cab is spacious, has an ergonomic design and is very quiet. This ensures that the operator remains intent and fully concentrated throughout the working day and enables him to deliver a constantly high performance.

Deluxe Cab

Ergonomic Design

The modern cab design provides excellent conditions for healthy, concentrated and productive work in maximum comfort. The colour touchscreen display, the controls and operator's seat Comfort are all coordinated to form a perfect ergonomic unit. In addition the ergonomic joysticks allow the machine operation to be both pleasant and precise.

Excellent All-Round Vision

The large areas of glass, different versions of cab elevations and the rear and side area monitoring systems provide the operator with an excellent view of his working area and the zone around the machine. This perfect view enhances the operator's safety and ensures that he can handle the machine safely at all times.

Low Noise Levels

The use of viscoelastic mounts, good insulation and low-noise diesel engines from Liebherr minimizes noise emissions and vibrations. The noise levels are just 71 dB(A) in the operator's cab and 103 dB(A) outside. This means that the material handlers LH 40 and LH 50 have low noise to preserve people and the environment.

Comfortable Operation

Proportional Control

Precision and fine control of the material handling machine are especially important in applications such as waste separation or scrap recycling. Thanks to the standard proportional control, even such demanding operations can be mastered in style.

Steering and Stabilizer on Joystick

The standard joystick steering gives the operator an additional comfort boost. The steering movement can be conveniently executed using the joystick, eliminating the need to reposition during the work cycle. Abandoning the steering wheel in favour of joystick steering provides additional legroom and a clear view of the working area. A new standard feature is the control of the outriggers with the joystick for more comfort and an increased productivity of the machine.

Colour Touchscreen Display and Operation Unit

The 7" colour touchscreen display is intuitive in its operation and provides continuous information about all important operating data. The shortcut keys can be individually assigned and are selected quickly and easily with the menu strip.



Safe Access

- Wide, non-slip steps, catwalks and platforms, and ergonomically positioned handles for an easy and safe access
- All access systems are designed to national guidelines and statutory regulations
- Sliding door for comfortable entry with narrow platforms is available as an option

Operator's Seat Comfort with Adjustable Armrests

- Greater seating comfort due to variable damper hardness, lockable horizontal suspension, pneumatic lumbar support, seat heating and passive seat air conditioning for concentrated working
- Individual adjustment options for armrests, seat cushion depth, seat angle and head restraint for healthful working

Joystick with Proportional Control

- Good functionality with streamlined, ergonomic design
- 4-way mini-joystick enables versatile possibilities of control without having to encompass, for example steering, outriggers or working tools
- Two buttons and a rocker switch also increase the number of functions

Maintainability



Efficiency bonus – Even with maintenance and service

The Liebherr material handling machines LH 40 and LH 50 are powerful, robust, precise and efficient. They also feature integral maintenance benefits as a result of their service-based machine design. The maintenance work for the Liebherr material handlers can be carried out quickly, easily and safely. This minimizes the material handling machine's maintenance costs and down times.

Elaborate Maintenance Concept Your Competent Service Partner

Service-Based Machine Design

The service-based machine design guarantees short servicing times, thus minimizing maintenance costs due to the time it saves. All the maintenance points are easily accessible from the ground or on catwalks and platforms, and easy to reach due to the large, wide-opening service doors. The enhanced service concept places the maintenance points close to each other and reduces their number to a minimum. This means that service work can be completed even more quickly and efficiently.

Integral Maintenance Benefits

Completing maintenance work helps keep the machine fully functional. Maintenance work does, however, mean machine down times which must be minimized. With change intervals of 2,000 hours for engine oil and up to 8,000 hours for hydraulic oil Liebherr reduce the amount of maintenance significantly and increase the productivity of the material handlers. In addition, central lubrication systems assist to optimize the daily amount of maintenance.

Remanufacturing

The Liebherr remanufacturing program offers cost-effective reconditioning of components to the highest quality standards. Various reconditioning levels are available: Replacement components, general overhaul or repair. The customer receives components with original part quality at a reduced cost.

Competent Advice and Service

Competent advice is a given at Liebherr. Experienced specialists provide decision guidance for your specific requirements: application-oriented sales support, service agreements, value-priced repair alternatives, original parts management, as well as remote data transmission for machine planning and fleet management.



Lubrication as it Works

- Fully automatic central lubrication system for uppercarriage and attachment
- Fully automatic central lubrication system for the undercarriage available as an option
- Lubricates without interrupting work to ensure better productivity and a long component service life

Excellent Service Access

- Large, wide-opening service doors
- Engine oil, fuel, air and cab air filters are easily and safely accessible from the ground or on catwalks and platforms
- The oil level in the hydraulic tank can be checked from the cab
- Short service times for more productivity

Rapid Spare Parts Service

- 24-hour delivery: Spare parts service is available for our dealers around the clock
- Electronic spare parts catalogue: Fast and reliable selection and ordering via the Liebherr online portal
- With online tracking, the current processing status of your order can be viewed at any time

Material Handling Machines Overview

Superbly Designed

Attachment for Maximum Reliability

- FEM-enhanced components
- Liebherr hydraulic cylinders
- Wide selection of Liebherr working tools (optional)
- Liebherr quick coupling systems (optional)
- Pipe fracture safety valves for hoisting and stick cylinders
- Overload warning device (optional)
- Working range limiters (optional)
- Load holding valve on stabilization cylinder
- Regeneration system for hoisting and stick cylinder

Ergonomic Operator's Work Station for Maximum Comfort

- Operator's seat Comfort
- Automatic air-conditioning system
- 7" large colour touchscreen display
- Direct access keys
- Adjustable armrests
- Ergonomic joysticks
- Joystick control
- Proportional control with mini-joystick
- Tool Control for working tools
- Large windows
- Easy radio control
- Hydraulic cab elevation with emergency lowering
- Front guard, adjustable (optional)
- Cab windows made of bullet-proof glass (optional)
- LED headlights (optional)
- Rear monitor
- Side monitor (optional)





Clever Technology for Maximum Performance and Economy

- Liebherr diesel engine compliant with stage Tier 4f
- Emissions treatment with Liebherr SCR technology
- Full power at just 1,800 rpm
- ERC system
- Load-sensing-control
- Liebherr-Power Efficiency (LPE)
- MODE selection (Sensitive, ECO, Power, Power-Plus)
- Preheating system for fuel, coolant, engine oil and hydraulic oil (optional)
- Sensor-controlled automatic idling system
- Automatic engine shut-down (optional)
- Close-mesh protective grid in front of cooler intake
- Electrical pilot control
- Closed hydraulic circuit for the swing mechanism

Elaborate Maintenance Concept for Maximum Productivity

- Fully automatic central lubrication system for uppercarriage and attachment
- Fully automatic central lubrication system for the undercarriage (optional)
- Large, wide-opening service doors
- Central maintenance points accessible from the ground or on catwalks and platforms
- Hydraulic shut-off cock
- Magnetic rod in the hydraulic system
- Liebherr hydraulic oil biologically degradable (optional)
- Retractable air-conditioning condenser
- Cab air filter can be replaced quickly and conveniently from outside
- Two lockable storage boxes
- Extended tool equipment (optional)

The Perfect Solution for Every Application

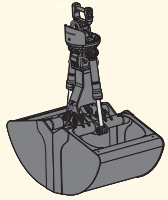

Shells for loose material

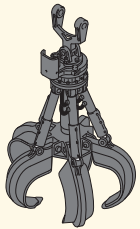

Multi-tine grab



Wood grab

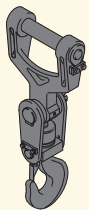

Load hook

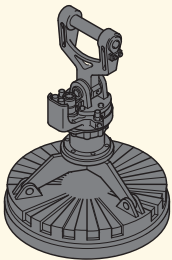

Magnet devices

Working Tools

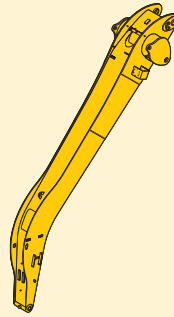

Angled stick

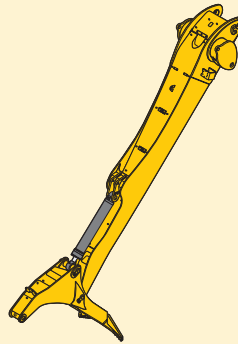

Stick with counterstay

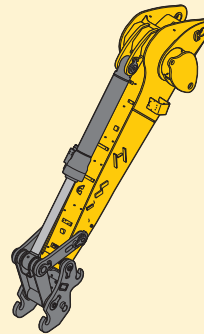

Stick for scrap shear

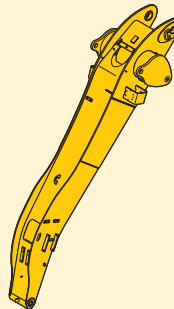

Flat angled stick

Sticks

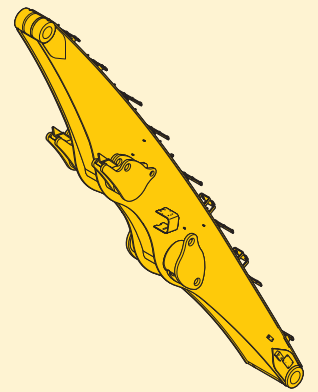

Straight boom

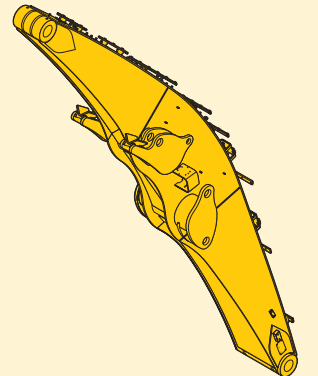

Angled boom

Booms

Cab Elevations

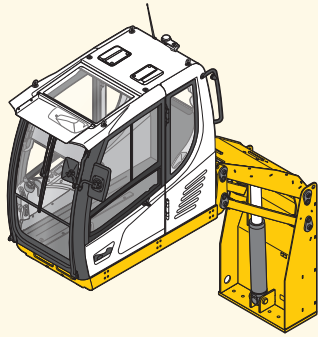

Hydraulic cab elevation

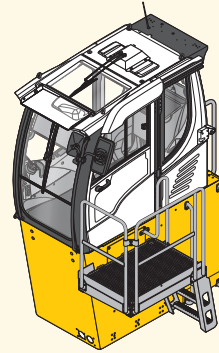

Rigid cab elevation

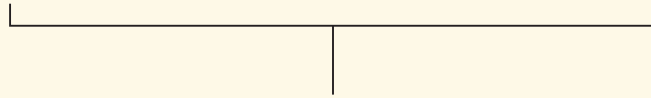

Uppercarriage

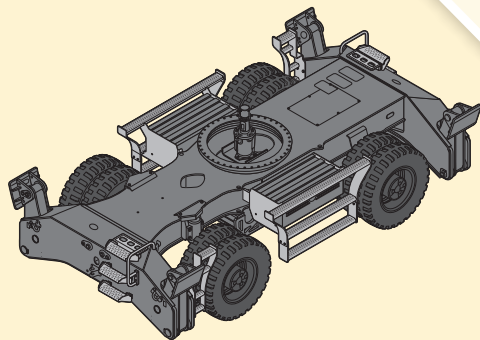

Mobile

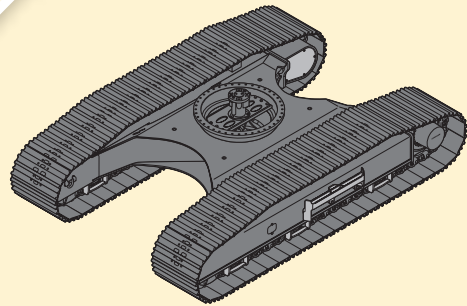

Crawler

Undercarriage

Experience the Progress

The invention of the mobile tower crane in 1949 also marked the birth of the Liebherr company. During its first decade the small construction company developed into an established manufacturer of construction machines and other technically advanced products. The R 353 and its first industrial attachment were launched in 1951 to lay the foundations for the

production of today's material handling machines. The A 911 mobile material handling machine a few years later enabled the company to make the breakthrough into material handling. Over the years the machines have been developed continually and today they are designed uncompromisingly for the industrial use.



First tower crane TK10

1949



Production plant in Kirchdorf

1970



First hydraulic cab elevation

1983

1961



R 353 with the first industrial attachment

1968

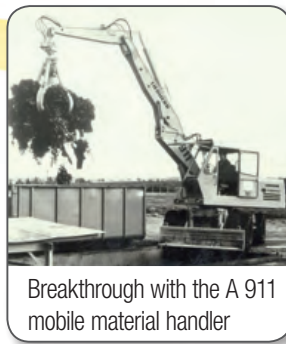

Breakthrough with the A 911 mobile material handler

1974



Silenced material handling machine

Liebherr has now been developing and manufacturing material handling machines for a very wide range of applications in the scrap, port and timber handling sectors and for the waste and recycling industry for over 50 years. In the development of its machines, Liebherr chooses quality, durability and reliability from the very outset, together with performance and economy.

Years of experience in design and construction are not only reflected in the end product but also in the components which are developed, designed and manufactured by Liebherr itself. This multiple sector expertise is used in product design from the early phase of the development process and thus allows high level technical innovations to be made.



Opening of the assembly building for material handling machines

2007



Launch of the lightweight stick

2011



Launch of the new LH series

2013

2010



Awarded the Bauma Design Prize for the LH 120



Awarded the Bauma Innovation Prize for the ERC cylinder

2014



Awarded the IF Award for the material handling machine LH 60

Technical Data



Diesel Engine

Rating	
per SAE J1349	208 HP (155 kW) at 1,800 rpm
per ISO 9249	211 HP (155 kW) at 1,800 rpm
Model	Liebherr D934
Type	4 cylinder in-line
Bore/Stroke	4.8/5.9 in
Displacement	427,17 in ³
Engine operation	4-stroke diesel Common-Rail turbo-charged and after-cooled reduced emissions
Air cleaner	dry-type air cleaner with pre-cleaner, primary and safety elements
Engine idling	sensor controlled
Electrical system	
Voltage	24 V
Batteries	2 x 180 Ah/12 V
Alternator	three-phase current 28 V/140 A
Stage Tier 4f	
Harmful emissions values	in accordance with EPA/CARB-40CFR stage Tier 4f
Emission control	Liebherr SCR technology
Fuel tank	122 gal
Urea tank	17 gal



Cooling System

Diesel engine	water-cooled compact cooling system consisting cooling unit for water, hydraulic oil and charge air with stepless thermostatically controlled fan
----------------------	--



Hydraulic Controls

Power distribution	via control valves with integrated safety valves, simultaneous actuation of chassis and attachment. Swing drive in separate closed circuit
Servo circuit	
Attachment and swing	with electro-hydraulic pilot control and proportional joystick levers
Chassis	
Mobile	electroproportional via foot pedal
Crawler	with electric proportionally functioning foot pedals or adjusted with plugable levers
Additional functions	via switch or electroproportional foot pedals
Proportional control	proportionally acting transmitters on the joysticks for additional hydraulic functions



Hydraulic System

Hydraulic pump	
for attachment and travel drive	2 Liebherr axial piston variable displacement pumps (double construction)
Max. flow	2 x 63 gpm
Max. pressure	5,076 psi
for swing drive	reversible axial piston variable displacement pump, closed-loop circuit
Max. flow	38 gpm
Max. pressure	5,366 psi
Hydraulic pump regulation and control	2 circuit Liebherr-Synchron-Comfort-system (LSC) with electronic engine speed sensing regulation, pressure and flow compensation, automatic oil flow optimizer
Hydraulic tank	75 gal
Hydraulic system	155 gal
Hydraulic oil filter	1 main return filter with integrated partial micro filtration (5 µm)
MODE selection	adjustment of engine and hydraulic performance via a mode pre-selector to match application, e.g. for especially economical and environmentally friendly operation or for maximum material handling and heavy-duty jobs
S (Sensitive)	mode for precision work and lifting through very sensitive movements
E (Eco)	mode for especially economical and environmentally friendly operation
P (Power)	mode for high performance with low fuel consumption
P+ (Power-Plus)	mode for highest performance and for very heavy duty applications, suitable for continuous operation
Engine speed and performance setting	stepless alignment of engine output and hydraulic power via engine speed
Option	Tool Control: ten preadjustable pump flows and pressures for add on tools



Swing Drive

Drive	Liebherr axial piston motor in a closed system, Liebherr planetary reduction gear
Swing ring	Liebherr, sealed race ball bearing swing ring, internal teeth
Swing speed	0 – 7.5 rpm stepless
Swing torque	61,955 lbf ft
Holding brake	wet multi-disc (spring applied, pressure released)
Option	pedal controlled positioning swing brake



Operator's Cab

Cab	TOPS safety cab structure (tip-over protection) with individual windscreens or featuring a slide-in subpart under the ceiling, work headlights integrated in the ceiling, a door with a sliding window (can be opened on both sides), large stowing and depositing possibilities, shock-absorbing suspension, sounddamping insulating, tinted laminated safety glass, separate shades for the sunroof window and windscreen
Operator's seat	
Comfort	air cushioned operator's seat with headrest, lap belt, seat heater, adjustable seat cushion inclination and length, lockable horizontal suspension, automatic weight adjustment, adjustable suspension stiffness, pneumatic lumbar vertebrae support and passive seat climatisation with active coal
Option	
Premium	in addition to operator's seat comfort: active electronic weight adjustment (automatic readjustment), pneumatic low frequency suspension and active seat climatisation with active coal and ventilator
Control system	joysticks with arm consoles and swivel seat
Operation and displays	large high-resolution operating unit, selfexplanatory, color display with touchscreen, video-compatible, numerous setting, control and monitoring options, e.g. air conditioning control, fuel consumption, machine and tool parameters
Air-conditioning	automatic air-conditioning, recirculated air function, fast de-icing and demisting at the press of a button, air vents can be operated via a menu; recirculated air and fresh air filters can be easily replaced and are accessible from the outside; heating-cooling unit, designed for extreme out-side temperatures, sensors for solar radiation, inside and outside temperatures



Attachment

Type	high-strength steel plates at highllystressed points for the toughest requirements. Complex and stable mountings of attachment and cylinders
Hydraulic cylinders	Liebherr cylinders with special seal system as well as shock absorption
Energy recovering cylinder	Liebherr gas cylinder with special sealing and control system
Bearings	sealed, low maintenance



Undercarriage

Mobile	
Drive	oversized two speed power shift transmission with additional creeper speed, Liebherr axial piston motor with functional brake valve on both sides
Travel speed	
Joystick steering	0 – 1.9 mph stepless (creeper speed + transmission stage 1) 0 – 3.1 mph stepless (transmission stage 1) 0 – 7.5 mph stepless (creeper speed + transmission stage 2) 0 – 7.5 mph stepless (transmission stage 2)
Option	
Wheel steering	0 – 1.9 mph stepless (creeper speed + transmission stage 1) 0 – 3.1 mph stepless (transmission stage 1) 0 – 7.5 mph stepless (creeper speed + transmission stage 2) 0 – 12.4 mph stepless (transmission stage 2)
Driving operation	automotive driving using accelerator pedal, cruise control function: storage of variable accelerator pedal positions
Axles	132,277 lb / 154,324 lb drive axles (LH 40 M / LH 50 M); manual or automatic hydraulically controlled front axle oscillation lock
Service brake	two circuit travel brake system with accumulator; wet and backlash-free disc brake
Holding brake	wet multi-disc (spring applied, pressure released)
Stabilization	4 point outriggers
Option	blade, at the front, for 4 point outriggers
Crawler	
Version	EW
Drive	Liebherr compact planetary reduction gear with Liebherr axial piston motor per side of undercarriage
Travel speed	0 – 1.9 mph stepless (creeper speed) 0 – 2.7 mph stepless
Brake	functional brake valves on both sides
Holding brake	wet multi-disc (spring applied, pressure released)
Track pads	triple grouser, flat
Tracks	sealed and greased



Complete Machine

Lubrication	Liebherr central lubrication system for uppercarriage and attachment, automatically
Option	
Mobile	Liebherr central lubrication system for undercarriage, automatically
Steps system	parts hot-dip galvanised, nonskid surface
Noise emission	
ISO 6396	L_{pA} (inside cab) = 71 dB(A)
2000/14/EC	L_{WA} (surround noise) = 103 dB(A)

LH 40 M - Dimensions

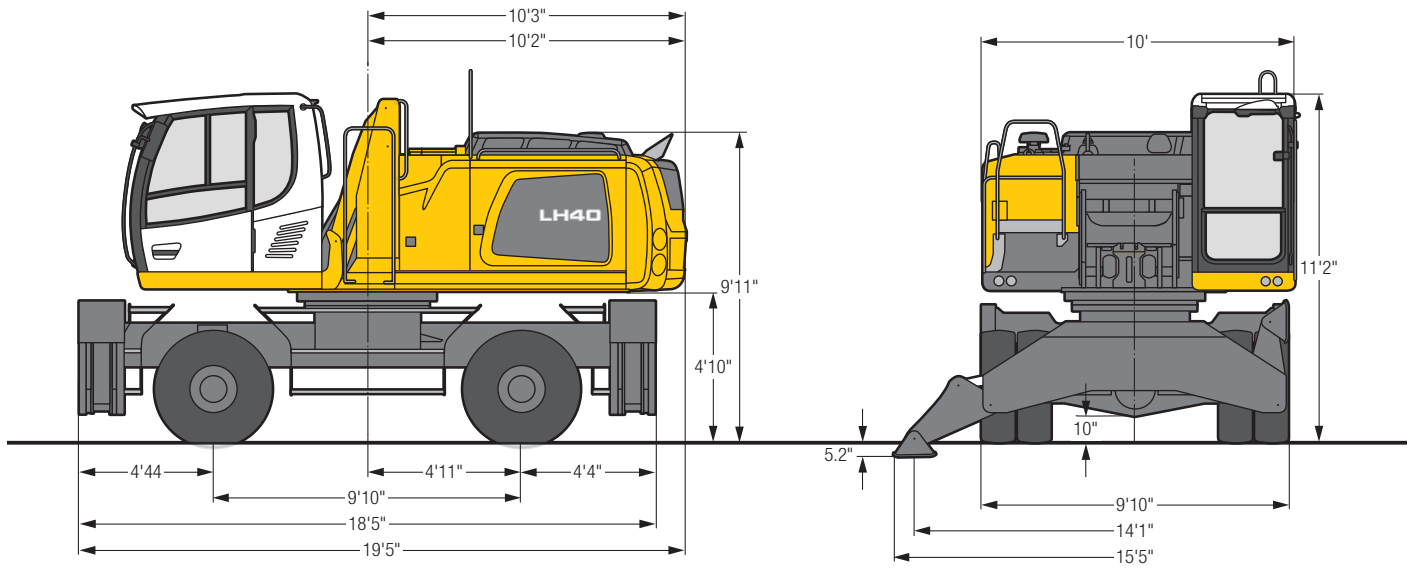

LH 40 M - Choice of Cab Elevation

Cab Elevation LFC (Rigid Elevation)

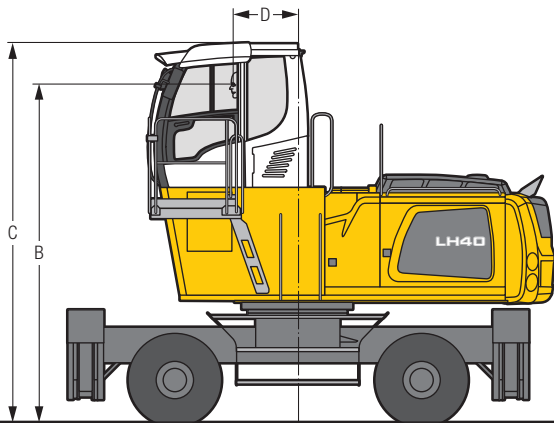

Increase type	LFC 120
Height	3'11"
B	13' 7"
C	15' 3"
D	2' 7"

A rigid cab elevation has a fixed eye level height. For a lower transport height, the shell of the cab can be removed and replaced by a transport device. The dimension C is in this machine design for all rigid cab elevations 12'3".

Cab Elevation LHC (Hydraulic Elevation)

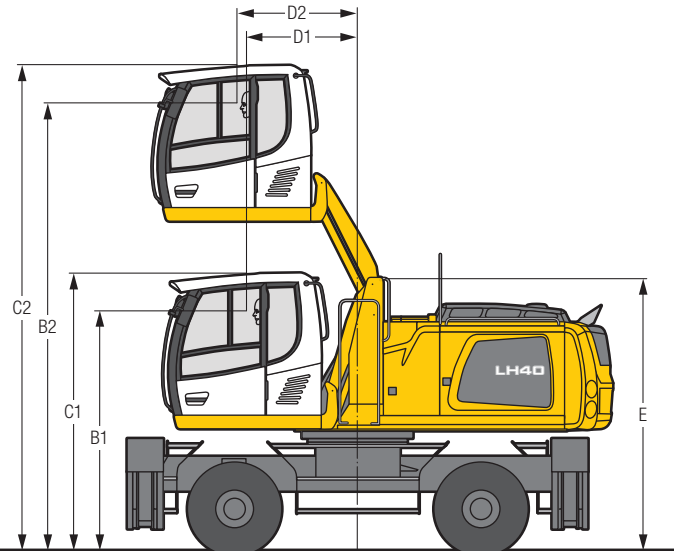

Increase type	LHC 255
B1	9' 8"
B2	18'
C1	11' 2"
C2	19' 6"
D1	4' 5"
D2	4'10"
E	11'

The hydraulically adjustable cab allows the driver, that he can choose his field of view freely and at any time within the stroke.

Tires 12.00-20

LH 50 M - Dimensions

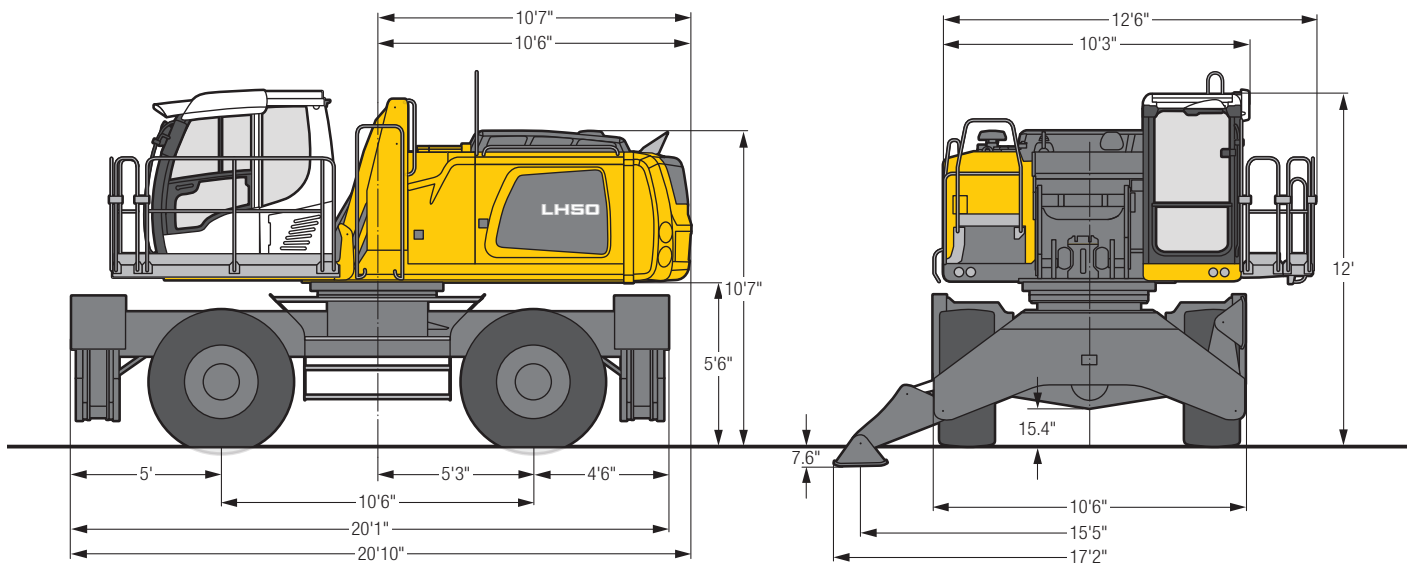

LH 50 M - Choice of Cab Elevation

Cab Elevation LFC (Rigid Elevation)

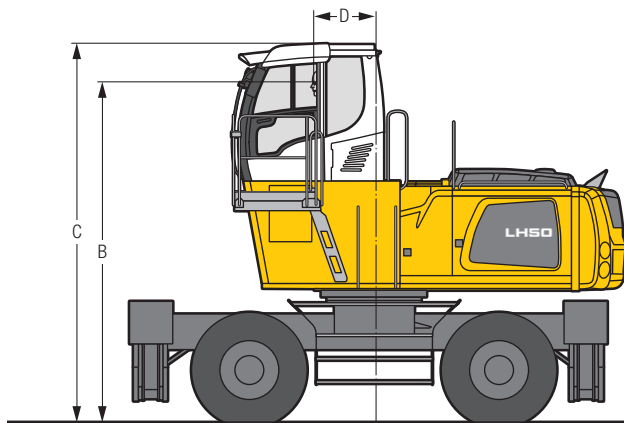

Increase type	LFC 120
Height	3'11"
B	14' 3"
C	15'11"
D	2' 7"

A rigid cab elevation has a fixed eye level height. For a lower transport height, the shell of the cab can be removed and replaced by a transport device. The dimension C is in this machine design for all rigid cab elevations 13'.

Cab Elevation LHC (Hydraulic Elevation)

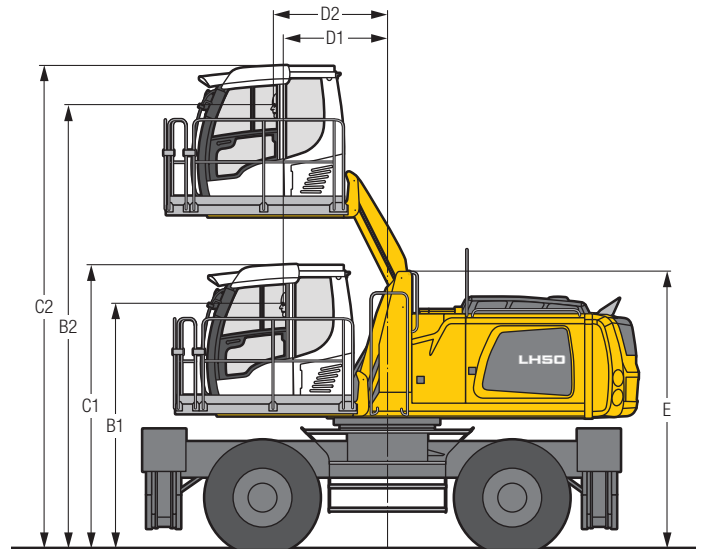

Increase type	LHC 255	LHC 340-35
B1	10' 4"	11' 6"
B2	18' 8"	22' 8"
C1	12'	13' 1"
C2	20' 4"	24' 4"
D1	4' 5"	8' 1"
D2	4'10"	8' 1"
E	11' 8"	12'11"

The hydraulically adjustable cab allows the driver, that he can choose his field of view freely and at any time within the stroke.

Tires 16.00-25

LH 40 C - Dimensions

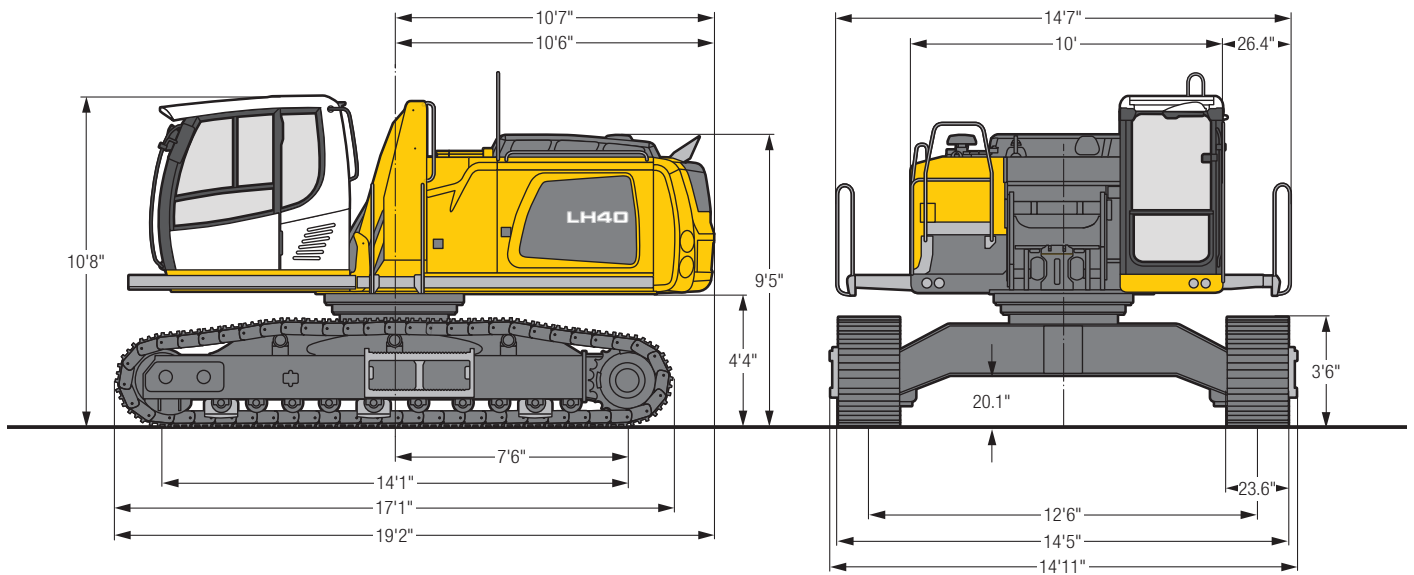

LH 40 C - Choice of Cab Elevation

Cab Elevation LFC (Rigid Elevation)

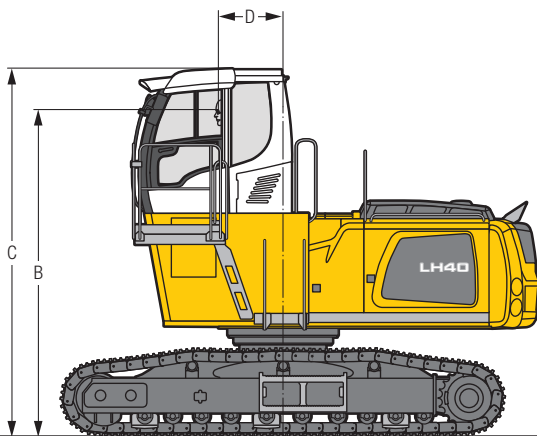

Increase type	LFC 120
Height	3'11"
B	13' 1"
C	14' 8"
D	2' 7"

A rigid cab elevation has a fixed eye level height. For a lower transport height, the shell of the cab can be removed and replaced by a transport device. The dimension C is in this machine design for all rigid cab elevations 11'9".

Cab Elevation LHC (Hydraulic Elevation)

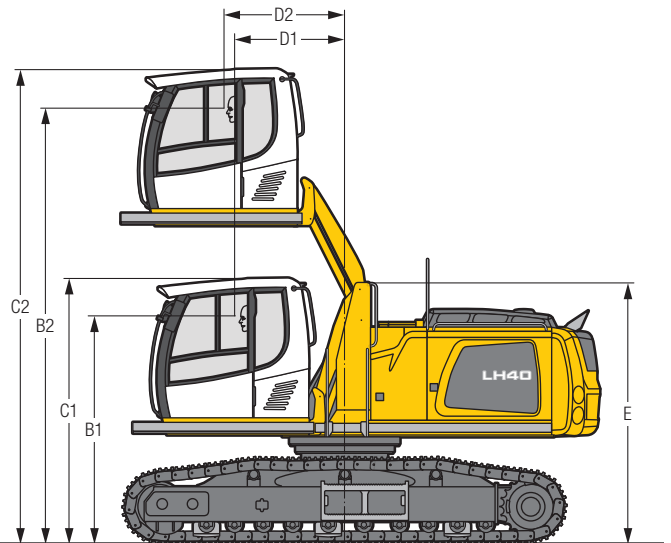

Increase type	LHC 255
B1	9' 1"
B2	17' 6"
C1	10' 8"
C2	19'
D1	4' 5"
D2	4'10"
E	10' 5"

The hydraulically adjustable cab allows the driver, that he can choose his field of view freely and at any time within the stroke.

Kinematic Variant 2A

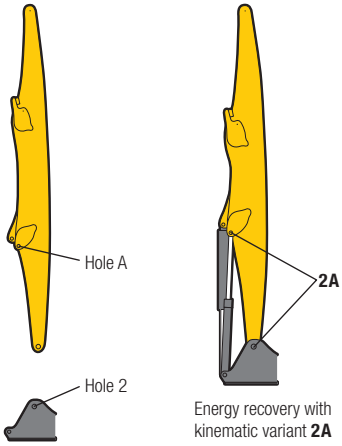

Kinematic Variant 2D/2C

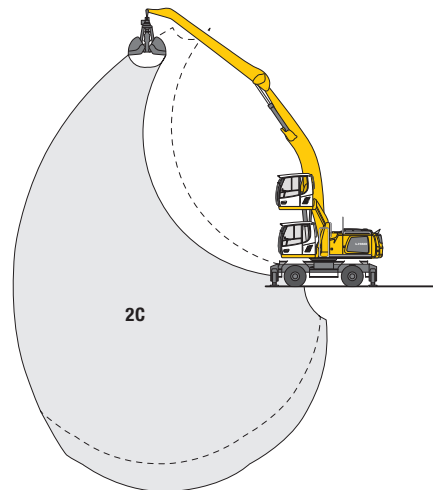
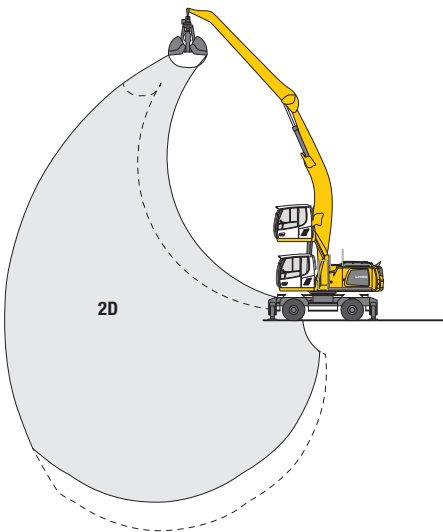
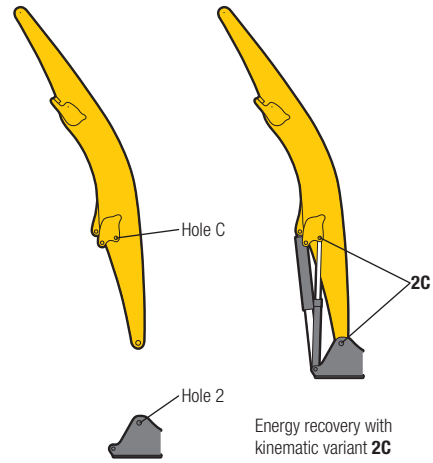
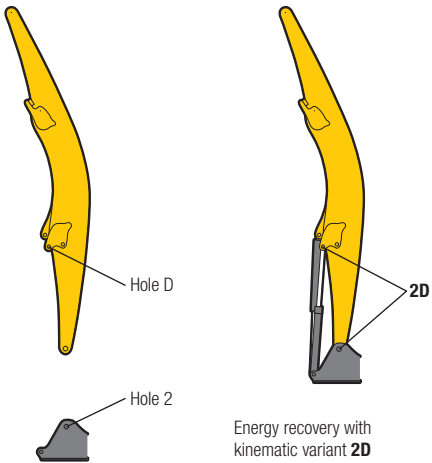

Altered range curve with additional reach depth, e.g. for unloading from ships

LH 40 M - Attachment GA13

Industry – Kinematic 2A

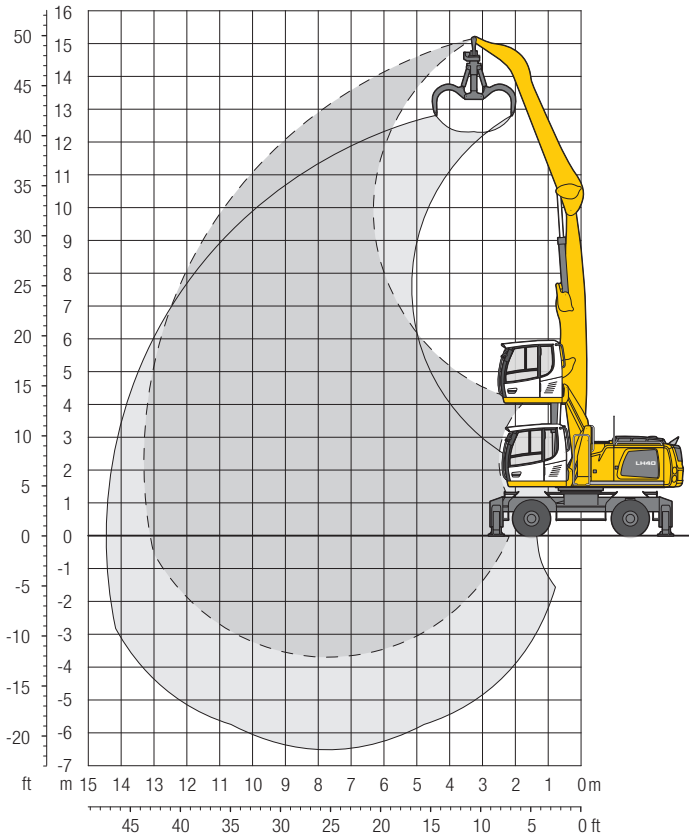

Operating Weight

The operating weight includes the basic machine with 4 point outriggers, hydr. cab elevation, 8 solid tires plus intermediate rings, straight boom 24'11", angled stick 19'8" and grab model GM 70C/1.05 yd³ semi-closed tines.

Weight 84,200 lb

Dimensions

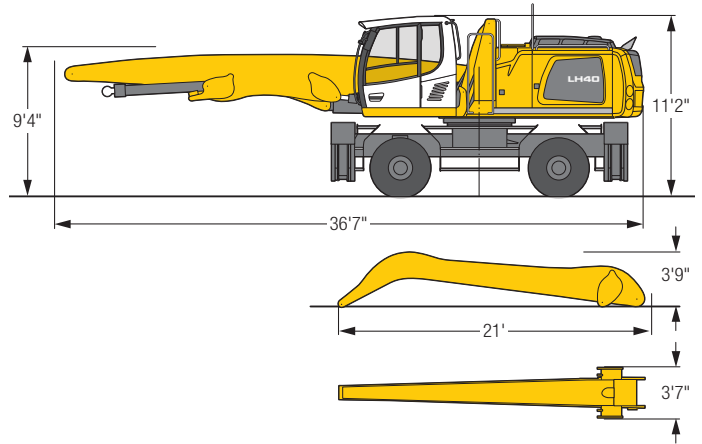

ft	Undercarriage	15 ft		20 ft		25 ft		30 ft		35 ft		40 ft		45 ft		50 ft		55 ft		ft in	
		Stabilizers raised	4 pt. outriggers down	Stabilizers raised	4 pt. outriggers down	Stabilizers raised	4 pt. outriggers down	Stabilizers raised	4 pt. outriggers down	Stabilizers raised	4 pt. outriggers down	Stabilizers raised	4 pt. outriggers down	Stabilizers raised	4 pt. outriggers down	Stabilizers raised	4 pt. outriggers down	Stabilizers raised	4 pt. outriggers down	Stabilizers raised	4 pt. outriggers down
50																					
45				18,3*	18,3*															15,3*	15,3*
40				18,3*	18,3*															10,6	12,9*
35				20,5	21,5*	14,1	17,9													12,9*	12,9*
30				21,5*	21,5*	18,3*	18,3*													8,1	10,6
25						14,5	18,3*	10,5	13,4											11,7*	11,7*
20						18,3*	18,3*	16,5*	16,5*											6,8	8,9
15						14,5	18,2*	10,5	13,5	7,9	10,2									11,1*	11,1*
10						18,2*	18,2*	16,3*	16,3*	14,9*	14,9*									5,9	7,9
5												5,9	7,9							10,7*	10,7*
0												10,8*	10,8*							5,3	7,2
-5												12,4	13,4*							10,6*	10,6*
-10												15,0*	15,0*	12,4	13,4*					5,0	6,7
												17,4*	17,4*	12,3	13,4*					10,6*	10,6*
												17,4*	17,4*	12,3	13,4*					4,8	6,5
												17,9*	17,9*	12,1	13,2*					10,6	10,8*
												14,8	15,4*	12,1	13,2*					4,7	6,4
												7,0	9,3	5,6	7,5					10,5	10,6*
												6,2	8,5	5,2	7,1					4,7	6,5
												6,2	8,5	5,2	7,1					9,6*	9,6*
												13,6*	13,6*	10,1*	10,1*					6,3	8,7
												14,5*	14,5*							11,7*	11,7*

Height **Can be slewed through 360°** **In longitudinal position of undercarriage** **Max. reach** * Limited by hydr. capacity

The lift capacities on the stick end without attachment are stated in lb x 1,000 and are valid on a firm, level supporting surface with blocked oscillating axle. These capacities can be slewed through 360° with the undercarriage in the transverse position. Capacities in the longitudinal position of the undercarriage (+/- 15°) are specified over the steering axle with the stabilizers raised and over the rigid axle with the stabilizers down. Indicated loads based on the ISO 10567 standard and do not exceed 75% of tipping or 87% of hydraulic capacity. The lift capacity values indicated are attained at the corresponding operating temperature. This operating temperature is ensured by continuous movement of the boom. Weights of fitted working tools (grabs, load hooks, etc.) and load accommodation equipment are to be deducted from the lift capacity values. The lift capacity of the unit is limited by its stability, the lifting capability of the hydraulic elements, or the maximum permissible lifting capacity of the load hook.

LH 40 M - Attachment GA14

Industry – Kinematic 2A

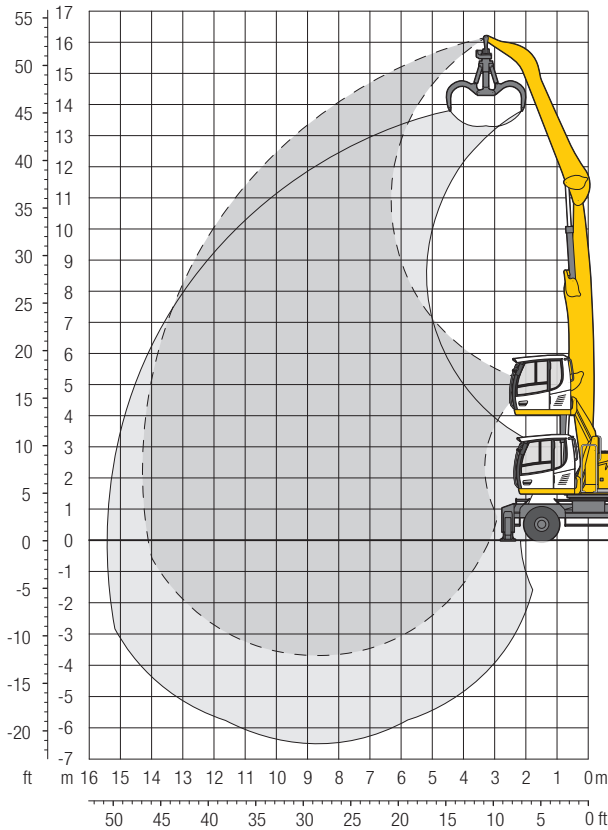

Operating Weight

The operating weight includes the basic machine with 4 point outriggers, hydr. cab elevation, 8 solid tires plus intermediate rings, straight boom 28'3" angled stick 19'8" and grab model GM 70C/ 1.05 yd³ semi-closed tines.

Weight 84,900 lb

Dimensions

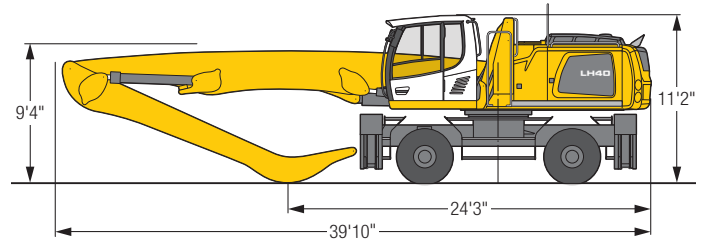

ft	15 ft		20 ft		25 ft		30 ft		35 ft		40 ft		45 ft		50 ft		55 ft		ft in		
	Stabilizers raised	4 pt. outriggers down	Stabilizers raised	4 pt. outriggers down	Stabilizers raised	4 pt. outriggers down	Stabilizers raised	4 pt. outriggers down	Stabilizers raised	4 pt. outriggers down	Stabilizers raised	4 pt. outriggers down	Stabilizers raised	4 pt. outriggers down	Stabilizers raised	4 pt. outriggers down	Stabilizers raised	4 pt. outriggers down	Stabilizers raised	4 pt. outriggers down	
50	21,6*	21,6*																	17,0*	17,0*	19' 6"
45			20,2	21,1*	13,8	17,5*													11,1	13,6*	28'
40					14,4	18,0*	10,3	13,3											8,0	10,5	33' 8"
35					14,5	17,8*	10,5	13,5	7,8	10,1									6,4	8,5	38'
30			20,6	21,0*	14,3	17,9*	10,4	13,3	7,8	10,1	5,8	7,8						5,4	7,3	41' 1"	
25			19,8	21,8*	13,7	17,6	10,1	13,0	7,6	10,0	5,8	7,8						4,8	6,5	43' 6"	
20	28,0*	28,0*	18,4	23,1*	12,9	16,8	9,6	12,5	7,3	9,6	5,7	7,6	4,4	6,0				4,3	6,0	45' 2"	
15	25,6	32,5*	16,7	22,0	11,9	15,7	8,9	11,8	6,9	9,2	5,4	7,4	4,3	6,0				4,0	5,6	46' 4"	
10	21,6	30,2	14,7	19,9	10,8	14,5	8,2	11,1	6,5	8,8	5,2	7,1	4,1	5,8				3,8	5,4	46' 10"	
5	13,0*	13,0*	13,0	18,1	9,8	13,4	7,6	10,4	6,1	8,4	4,9	6,8	4,0	5,7				3,8	5,3	46' 10"	
0	11,5*	11,5*	11,9	17,0	9,0	12,6	7,1	9,9	5,7	8,0	4,7	6,6	3,9	5,6				3,0	5,4	46' 4"	
-5	13,1*	13,1*	23,6*	23,6*	19,3*	19,3*	15,9*	15,9*	13,1*	13,1*	10,5*	10,5*						4,1	5,8	43' 8"	
-10			11,2	16,2	8,4	11,9	6,6	9,4	5,4	7,7								5,0	7,0	37' 6"	

Height Can be slewed through 360° In longitudinal position of undercarriage Max. reach * Limited by hydr. capacity

The lift capacities on the stick end without attachment are stated in lb x 1,000 and are valid on a firm, level supporting surface with blocked oscillating axle. These capacities can be slewed through 360° with the undercarriage in the transverse position. Capacities in the longitudinal position of the undercarriage (+/- 15°) are specified over the steering axle with the stabilizers raised and over the rigid axle with the stabilizers down. Indicated loads based on the ISO 10567 standard and do not exceed 75% of tipping or 87% of hydraulic capacity. The lift capacity values indicated are attained at the corresponding operating temperature. This operating temperature is ensured by continuous movement of the boom. Weights of fitted working tools (grabs, load hooks, etc.) and load accommodation equipment are to be deducted from the lift capacity values. The lift capacity of the unit is limited by its stability, the lifting capability of the hydraulic elements, or the maximum permissible lifting capacity of the load hook.

LH 40 M - Attachment GA16

Industry – Kinematic 2A

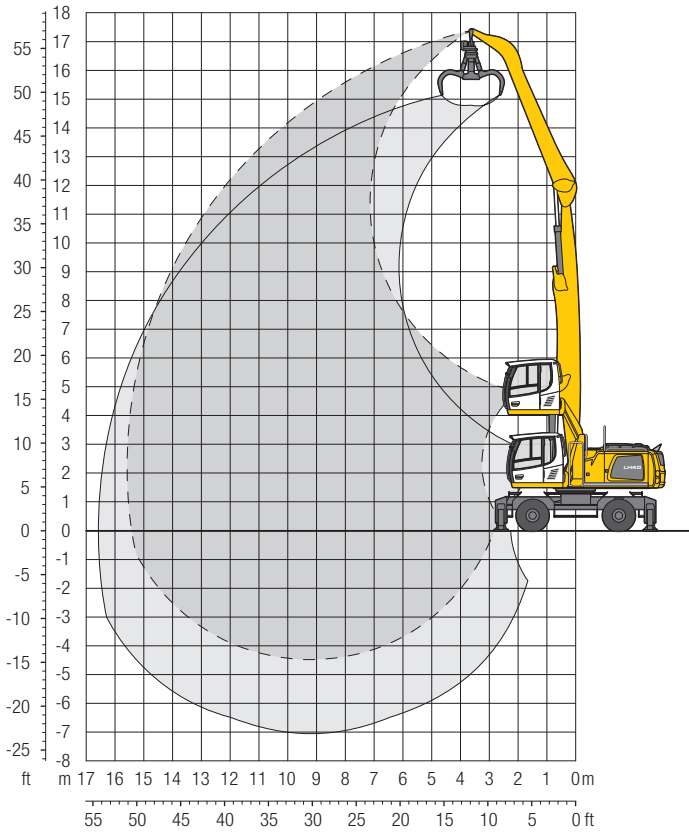

Operating Weight

The operating weight includes the basic machine with 4 point outriggers, hydr. cab elevation, 8 solid tires plus intermediate rings, straight boom 29'10", angled stick 22'4" and grab model GM 65/0.78 yd³ semi-closed tines.

Weight 84,900 lb

Dimensions

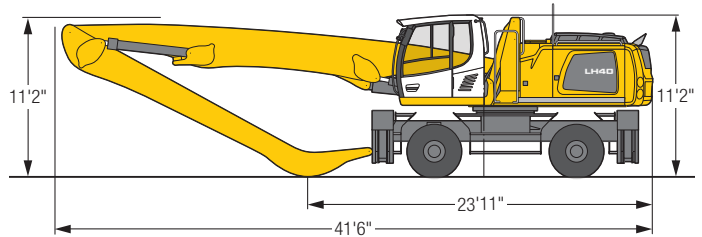

ft	Undercarriage	15 ft		20 ft		25 ft		30 ft		35 ft		40 ft		45 ft		50 ft		55 ft		ft in				
		Stabilizers raised	4 pt. outriggers down	Stabilizers raised	4 pt. outriggers down	Stabilizers raised	4 pt. outriggers down	Stabilizers raised	4 pt. outriggers down	Stabilizers raised	4 pt. outriggers down	Stabilizers raised	4 pt. outriggers down	Stabilizers raised	4 pt. outriggers down	Stabilizers raised	4 pt. outriggers down	Stabilizers raised	4 pt. outriggers down	Stabilizers raised	4 pt. outriggers down	ft in		
55	Stabilizers raised			19,5*	19,5*																16,3*	16,3*	18' 4"	
55	4 pt. outriggers down			19,5*	19,5*																16,3*	16,3*	18' 4"	
50	Stabilizers raised					18,9*	18,9*	14,1	15,9*												11,1	12,6*	28' 2"	
50	4 pt. outriggers down					18,9*	18,9*	15,9*	15,9*												12,6*	12,6*	28' 2"	
45	Stabilizers raised							14,8	17,3*	10,6	13,6										7,7	10,1	34' 7"	
45	4 pt. outriggers down							17,3*	17,3*	15,2*	15,2*										11,0*	11,0*	34' 7"	
40	Stabilizers raised							15,2	16,9*	10,9	13,9	8,0	10,4								6,0	8,0	39' 5"	
40	4 pt. outriggers down							16,9*	16,9*	14,9*	14,9*	13,4*	13,4*								10,1*	10,1*	39' 5"	
35	Stabilizers raised							15,1	16,9*	11,0	14,0	8,1	10,5	6,0	8,0						4,9	6,7	43'	
35	4 pt. outriggers down							16,9*	16,9*	14,8*	14,8*	13,2*	13,2*	12,0*	12,0*						9,6*	9,6*	43'	
30	Stabilizers raised							14,8	17,1*	10,7	13,7	8,0	10,4	6,0	8,0	4,5	6,2				4,2	5,9	45'11"	
30	4 pt. outriggers down							17,1*	17,1*	14,9*	14,9*	13,3*	13,3*	12,0*	12,0*	10,1	10,8*				9,3*	9,3*	45'11"	
25	Stabilizers raised			20,5	20,9*	14,1	17,6*	10,3	13,3	7,7	10,1	5,9	7,9	4,5	6,2						3,7	5,3	48'	
25	4 pt. outriggers down			20,9*	20,9*	17,6*	17,6*	15,2*	15,2*	13,4*	13,4*	12,0*	12,0*	10,1	10,8*						8,9	9,1*	48'	
20	Stabilizers raised					19,0	22,1*	13,2	17,1	9,7	12,6	7,3	9,7	5,6	7,6	4,3	6,0				3,4	4,9	49' 6"	
20	4 pt. outriggers down					22,1*	22,1*	18,3*	18,3*	15,6*	15,6*	13,7*	13,7*	12,1*	12,1*	10,0	10,8*				8,3	9,1*	49' 6"	
15	Stabilizers raised			26,3	31,2*	16,9	22,4	12,0	15,8	8,9	11,8	6,8	9,2	5,3	7,3	4,1	5,8	3,2	4,7		3,1	4,6	50' 6"	
15	4 pt. outriggers down			31,2*	31,2*	23,6*	23,6*	19,1*	19,1*	16,1*	16,1*	13,9*	13,9*	11,9	12,2*	9,8	10,7*	8,1	9,2*	7,9	8,9*	7,9	8,9*	50' 6"
10	Stabilizers raised			21,7	30,3	14,7	19,9	10,7	14,4	8,1	11,0	6,3	8,6	5,0	6,9	3,9	5,6	3,1	4,6		3,0	4,4	51'	
10	4 pt. outriggers down			34,0*	34,0*	25,0*	25,0*	19,9*	19,9*	16,5*	16,5*	14,1*	14,1*	11,5	12,2*	9,5	10,6*	8,0	8,9*	7,7	8,4*	7,7	8,4*	51'
5	Stabilizers raised			11,9*	11,9*	12,6	17,7	9,4	13,1	7,3	10,1	5,8	8,1	4,6	6,5	3,7	5,4	3,0	4,5		2,9	4,3	51'	
5	4 pt. outriggers down			11,9*	11,9*	25,8*	25,8*	20,3*	20,3*	16,7*	16,7*	13,6	14,1*	11,1	12,1*	9,3	10,3*	7,9	8,4*	7,6	7,8*	7,6	7,8*	51'
0	Stabilizers raised			9,7*	9,7*	11,2	16,2	8,5	12,1	6,7	9,5	5,3	7,6	4,3	6,2	3,5	5,2	2,9	4,4		2,9	4,3	50' 6"	
0	4 pt. outriggers down			9,7*	9,7*	25,3*	25,3*	20,1*	20,1*	16,3	16,5*	13,1	13,8*	10,8	11,7*	9,1	9,8*	7,4*	7,4*	7,0*	7,0*	7,0*	7,0*	50' 6"
-5	Stabilizers raised			10,8*	10,8*	10,4	15,4	7,9	11,4	6,2	9,0	5,0	7,3	4,1	6,0	3,4	5,1				3,0	4,6	48' 8"	
-5	4 pt. outriggers down			10,8*	10,8*	22,4*	22,4*	19,0*	19,0*	15,7*	15,7*	12,7	13,1*	10,6	10,9*	8,8*	8,8*				6,8*	6,8*	48' 8"	
-10	Stabilizers raised					10,1	15,0	7,5	11,1	5,9	8,7	4,8	7,1	4,0	5,9						3,5	5,2	44'	
-10	4 pt. outriggers down					20,2*	20,2*	16,9*	16,9*	14,1*	14,1*	11,7*	11,7*	9,5*	9,5*						7,6*	7,6*	44'	
-15	Stabilizers raised																							
-15	4 pt. outriggers down																							

Height **Can be slewed through 360°** **In longitudinal position of undercarriage** **Max. reach** *** Limited by hydr. capacity**

The lift capacities on the stick end without attachment are stated in lb x 1,000 and are valid on a firm, level supporting surface with blocked oscillating axle. These capacities can be slewed through 360° with the undercarriage in the transverse position. Capacities in the longitudinal position of the undercarriage (+/- 15°) are specified over the steering axle with the stabilizers raised and over the rigid axle with the stabilizers down. Indicated loads based on the ISO 10567 standard and do not exceed 75% of tipping or 87% of hydraulic capacity. The lift capacity values indicated are attained at the corresponding operating temperature. This operating temperature is ensured by continuous movement of the boom. Weights of fitted working tools (grabs, load hooks, etc.) and load accommodation equipment are to be deducted from the lift capacity values. The lift capacity of the unit is limited by its stability, the lifting capability of the hydraulic elements, or the maximum permissible lifting capacity of the load hook.

LH 40 M - Attachment AF15

Industry – Kinematic 2D

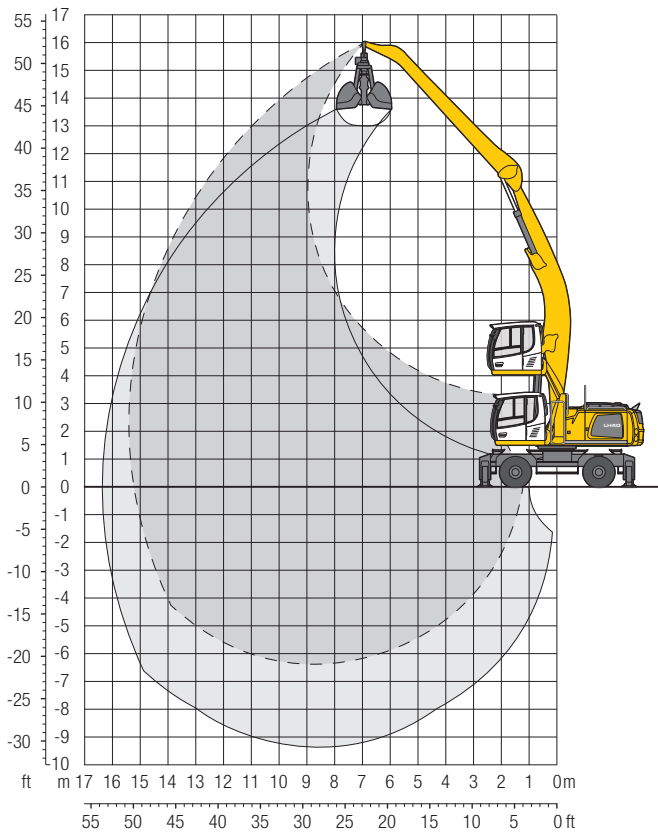

Operating Weight

The operating weight includes the basic machine with 4 point outriggers, hydr. cab elevation, 8 solid tires plus intermediate rings, angled boom 28'3", flat angled stick 24'7" and grab model GM 20C/1.96 yd³ shells for loose material.

Weight 86,200 lb

Dimensions

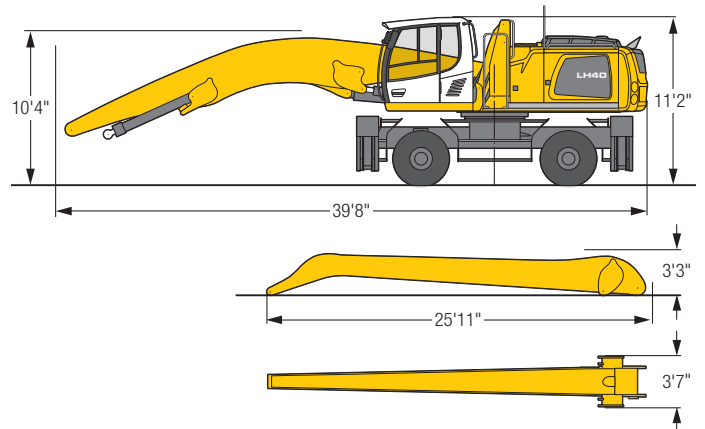

ft	Undercarriage	15 ft		20 ft		25 ft		30 ft		35 ft		40 ft		45 ft		50 ft		55 ft		ft in		
		Stabilizers raised	4 pt. outriggers down	Stabilizers raised	4 pt. outriggers down	Stabilizers raised	4 pt. outriggers down	Stabilizers raised	4 pt. outriggers down	Stabilizers raised	4 pt. outriggers down	Stabilizers raised	4 pt. outriggers down	Stabilizers raised	4 pt. outriggers down	Stabilizers raised	4 pt. outriggers down	Stabilizers raised	4 pt. outriggers down	Stabilizers raised	4 pt. outriggers down	Stabilizers raised
50				12,3*	12,3*															10,7*	10,7*	26'11"
45						11,4	12,5*													9,0	9,4*	33' 7"
40						11,8	12,6*	8,7	11,1											6,9	8,8*	38' 6"
35						11,9	12,5*	8,8	11,2	6,5	8,5									5,7	7,5	42' 2"
30						11,7	12,6*	8,7	11,2	6,6	8,6	4,8	6,6							4,8	6,5	45' 1"
25						11,3	12,9*	8,5	10,9	6,4	8,4	4,8	6,6							4,2	5,8	47' 4"
20						12,9*	12,9*	11,7*	11,7*	10,7*	10,7*	9,9*	9,9*							8,1*	8,1*	
15						14,7	15,2*	10,7	13,4*	8,1	10,5	6,2	8,2	4,7	6,4					3,8	5,3	48'10"
10						17,1	21,5*	12,1	16,0	9,1	12,0	6,9	9,3	5,4	7,4	4,2	5,9	3,3	4,8	3,2	4,7	
5		26,3	28,4*	17,1	21,5*	17,1	21,5*	12,1	16,0	9,1	12,0	6,9	9,3	5,4	7,4	4,2	5,9	3,3	4,8	3,2	4,7	
0		28,4*	28,4*	21,5*	21,5*	17,4*	17,4*	14,8*	14,8*	12,8*	12,8*	11,4*	11,4*	9,9	10,2*	8,2	9,1*			8,1	8,5*	50' 5"
-5		21,6	30,3	14,7	20,0	10,7	14,5	8,1	11,0	6,3	8,7	5,0	7,0	4,0	5,7	3,1	4,6			3,1	4,6	50' 4"
-10		31,7*	31,7*	23,3*	23,3*	18,5*	18,5*	15,4*	15,4*	13,2*	13,2*	11,6*	11,6*	9,6	10,2*	8,1	8,9*			8,0	8,8*	
-15		18,1	20,7*	12,7	17,8	9,5	13,2	7,3	10,2	5,8	8,1	4,6	6,6	3,7	5,4					3,0	4,5	49'10"
-20		20,7*	20,7*	24,4*	24,4*	19,2*	19,2*	15,8*	15,8*	13,5*	13,5*	11,2	11,7*	9,3	10,1*					8,0	8,6*	
		16,3	16,9*	11,3	16,4	8,5	12,2	6,7	9,5	5,3	7,6	4,3	6,3	3,5	5,2					3,1	4,6	48'10"
		16,9*	16,9*	24,7*	24,7*	19,4*	19,4*	16,0*	16,0*	13,1	13,4*	10,8	11,5*	9,1	9,8*					8,1	8,3*	
		15,4	16,8*	10,5	15,5	7,9	11,5	6,2	9,0	5,0	7,3	4,1	6,0	3,4	5,1					3,2	4,8	47' 2"
		16,8*	16,8*	23,8*	23,8*	19,0*	19,0*	15,6*	15,6*	12,8	13,0*	10,6	11,0*	9,0*	9,0*					7,9*	7,9*	
		15,2	17,8*	10,2	15,2	7,6	11,2	5,9	8,7	4,8	7,1	4,0	5,9							3,5	5,2	44' 5"
		17,8*	17,8*	21,7*	21,7*	17,6*	17,6*	14,5*	14,5*	12,0*	12,0*	9,8*	9,8*							7,7*	7,7*	
						7,5	11,1	5,9	8,7	4,8	7,1									4,8	7,1	35' 1"
						15,1*	15,1*	12,4*	12,4*	10,1*	10,1*									10,0*	10,0*	

↑ Height ↻ Can be slewed through 360° ⬆ In longitudinal position of undercarriage 🚛 Max. reach * Limited by hydr. capacity

The lift capacities on the stick end without attachment are stated in lb x 1,000 and are valid on a firm, level supporting surface with blocked oscillating axle. These capacities can be slewed through 360° with the undercarriage in the transverse position. Capacities in the longitudinal position of the undercarriage (+/- 15°) are specified over the steering axle with the stabilizers raised and over the rigid axle with the stabilizers down. Indicated loads based on the ISO 10567 standard and do not exceed 75% of tipping or 87% of hydraulic capacity. The lift capacity values indicated are attained at the corresponding operating temperature. This operating temperature is ensured by continuous movement of the boom. Weights of fitted working tools (grabs, load hooks, etc.) and load accommodation equipment are to be deducted from the lift capacity values. The lift capacity of the unit is limited by its stability, the lifting capability of the hydraulic elements, or the maximum permissible lifting capacity of the load hook.

LH 40 M - Attachment GS11

Industry – Kinematic 2A

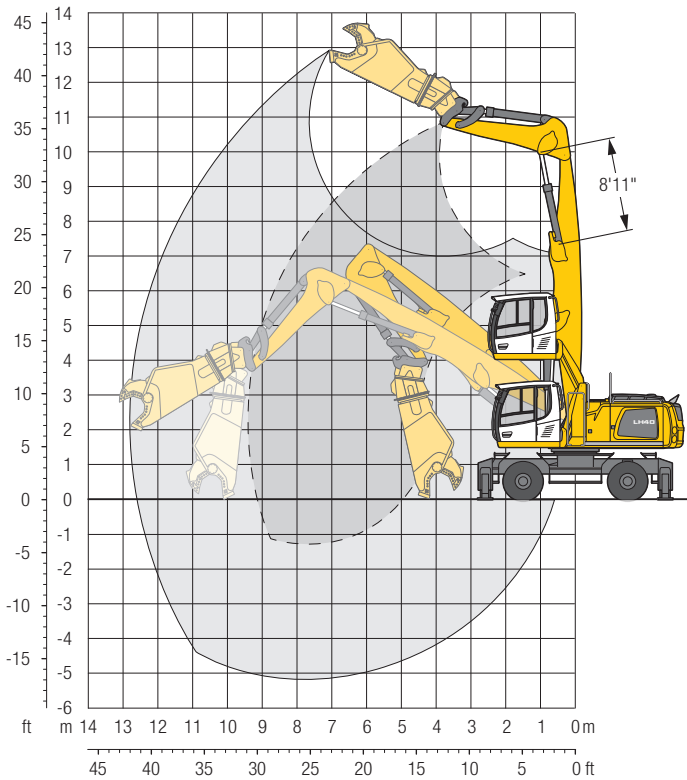

Operating Weight

The operating weight includes the basic machine with 4 point outriggers, hydr. cab elevation, 8 solid tires plus intermediate rings, straight boom 24'11", stick HD with tipping kinematics special 11'10", quick coupler SW66 and scrap shear Genesis GTX 445R.

Weight 95,000 lb

The stick cylinder must be limited to the measure of 8'11".

Dimensions

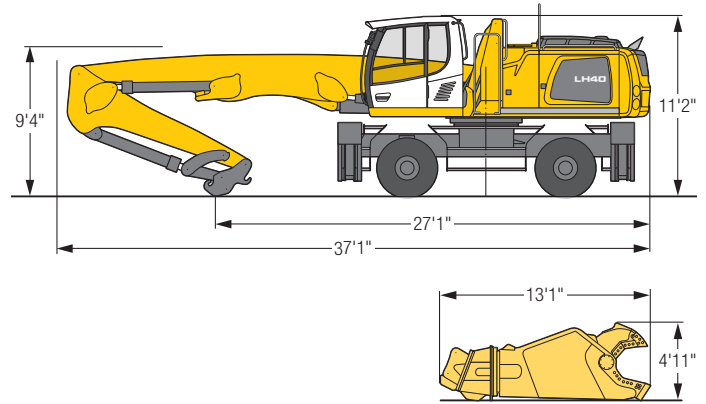

ft	Undercarriage	15 ft		20 ft		25 ft		30 ft		35 ft		40 ft		45 ft		50 ft		55 ft		ft in		
		Stabilizers raised	4 pt. outriggers down	Stabilizers raised	4 pt. outriggers down	Stabilizers raised	4 pt. outriggers down	Stabilizers raised	4 pt. outriggers down	Stabilizers raised	4 pt. outriggers down	Stabilizers raised	4 pt. outriggers down	Stabilizers raised	4 pt. outriggers down	Stabilizers raised	4 pt. outriggers down	Stabilizers raised	4 pt. outriggers down	Stabilizers raised	4 pt. outriggers down	
45	Stabilizers raised																					
45	4 pt. outriggers down					8,8*	8,8*														7,4	8,1*
40	Stabilizers raised																				8,1*	8,1*
40	4 pt. outriggers down																				3,1	5,7*
35	Stabilizers raised							4,3	6,3*												5,7*	5,7*
35	4 pt. outriggers down							6,3*	6,3*												0,7	3,2
30	Stabilizers raised							4,3	6,2*	0,9	3,4										4,3*	4,3*
30	4 pt. outriggers down							6,2*	6,2*	4,4*	4,4*										4,3*	4,3*
25	Stabilizers raised					8,6*	8,6*	3,9	6,2*	0,7	3,2										1,4	1,4
25	4 pt. outriggers down					8,6*	8,6*	6,2*	6,2*	4,4*	4,4*										3,4*	3,4*
20	Stabilizers raised					7,8	8,9*	3,2	6,3	0,2	2,7										–	0,2
20	4 pt. outriggers down					8,9*	8,9*	6,4*	6,4*	4,4*	4,4*	2,8*	2,8*								2,8*	2,8*
15	Stabilizers raised			8,8*	8,8*	6,3	9,3*	2,3	5,3	–	2,1	–	–								–	–
15	4 pt. outriggers down			8,8*	8,8*	9,3*	9,3*	6,5*	6,5*	4,5*	4,5*	2,7*	2,7*								2,3*	2,3*
10	Stabilizers raised	6,3*	6,3*	10,0	14,0*	4,5	8,4	1,1	4,1	–	1,3	–	–								–	–
10	4 pt. outriggers down	6,3*	6,3*	14,0*	14,0*	9,6*	9,6*	6,7*	6,7*	4,4*	4,4*	2,6*	2,6*								1,9*	1,9*
5	Stabilizers raised	13,9	22,4*	6,6	12,0	2,5	6,3	–	2,9	–	0,5	–	–								–	–
5	4 pt. outriggers down	22,4*	22,4*	14,5*	14,5*	9,8*	9,8*	6,6*	6,6*	4,2*	4,2*	2,3*	2,3*								1,6*	1,6*
0	Stabilizers raised	8,5	16,8	3,7	8,9	0,8	4,5	–	1,7	–	–	–	–								–	–
0	4 pt. outriggers down	18,9*	18,9*	14,3*	14,3*	9,5*	9,5*	6,2*	6,2*	3,8*	3,8*	1,7*	1,7*								1,2*	1,2*
-5	Stabilizers raised	5,3	10,0*	1,6	6,7	–	3,1	–	0,8	–	–	–	–								–	–
-5	4 pt. outriggers down	10,0*	10,0*	13,0*	13,0*	8,6*	8,6*	5,4*	5,4*	2,9*	2,9*	–	–								0,6*	0,6*
-10	Stabilizers raised	3,8	10,6*	0,5	5,4	–	2,2	–	0,2	–	–	–	–								–	–
-10	4 pt. outriggers down	10,6*	10,6*	10,4*	10,4*	6,7*	6,7*	3,8*	3,8*	1,3*	1,3*	–	–								–	–
-15	Stabilizers raised					–	4,9	–	1,8	–	–	–	–								–	–
-15	4 pt. outriggers down			6,1*	6,1*	3,5*	3,5*	1,1*	1,1*	–	–	–	–								–	–

Height
 Can be slewed through 360°
 In longitudinal position of undercarriage
 Max. reach
 * Limited by hydr. capacity

The lift capacities on the stick end without attachment are stated in lb x 1,000 and are valid on a firm, level supporting surface with blocked oscillating axle. These capacities can be slewed through 360° with the undercarriage in the transverse position. Capacities in the longitudinal position of the undercarriage (+/- 15°) are specified over the steering axle with the stabilizers raised and over the rigid axle with the stabilizers down. Indicated loads based on the ISO 10567 standard and do not exceed 75% of tipping or 87% of hydraulic capacity. The lift capacity values indicated are attained at the corresponding operating temperature. This operating temperature is ensured by continuous movement of the boom. Weights of fitted working tools (grabs, load hooks, etc.) and load accommodation equipment are to be deducted from the lift capacity values. The lift capacity of the unit is limited by its stability, the lifting capability of the hydraulic elements, or the maximum permissible lifting capacity of the load hook.

LH 40 M - Attachment GSV14

Industry – Kinematic 2A

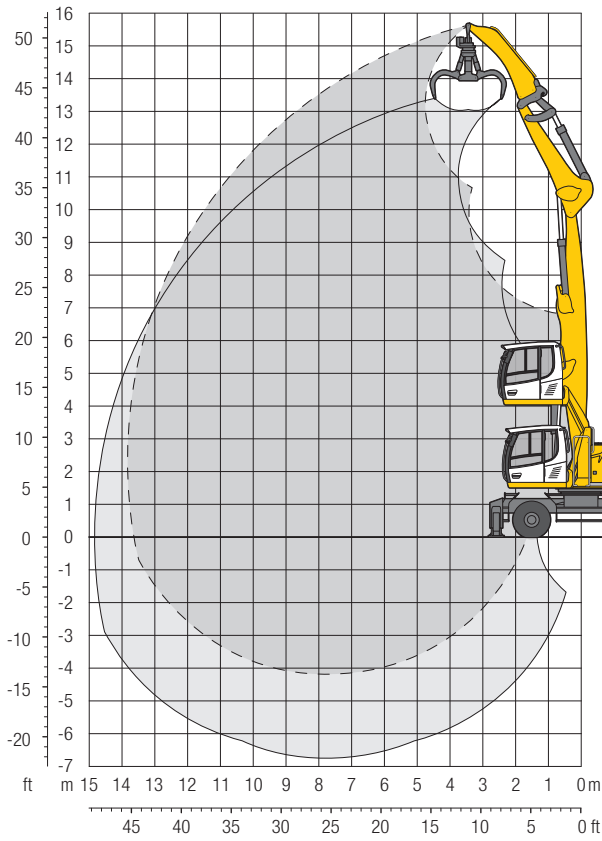

Operating Weight

The operating weight includes the basic machine with 4 point outriggers, hydr. cab elevation, 8 solid tires plus intermediate rings, straight boom 24'11", stick HD with tipping kinematics special 11'10", quick coupler SW66, stick extension 8'10" and grab model GM 65/0.78 yd³ semi-closed tines.

Weight 88,600 lb

Dimensions

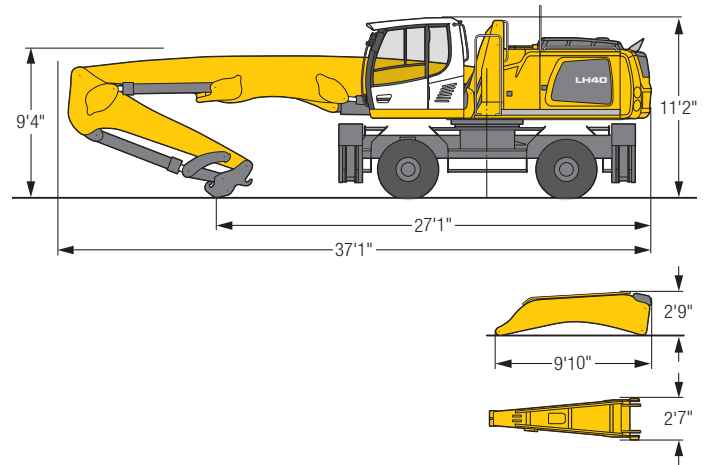

ft	Undercarriage	15 ft		20 ft		25 ft		30 ft		35 ft		40 ft		45 ft		50 ft		55 ft		ft in	
		Stabilizers raised	4 pt. outriggers down	Stabilizers raised	4 pt. outriggers down	Stabilizers raised	4 pt. outriggers down	Stabilizers raised	4 pt. outriggers down	Stabilizers raised	4 pt. outriggers down	Stabilizers raised	4 pt. outriggers down	Stabilizers raised	4 pt. outriggers down	Stabilizers raised	4 pt. outriggers down	Stabilizers raised	4 pt. outriggers down	Stabilizers raised	4 pt. outriggers down
50		17,3*	17,3*																	17,1*	17,1*
45		17,3*	17,3*																	17,1*	17,1*
40				17,4*	17,4*	11,9	12,3*													11,6	12,0*
35				17,4*	17,4*	12,3*	12,3*	8,4	11,4											12,0*	12,0*
30						13,0	16,1*	8,4	11,4											7,3	10,1*
25						16,1*	16,1*	12,3*	12,3*											10,1*	10,1*
20						13,4	15,6*	8,9	11,9	5,7	8,1									5,2	7,5
15						15,6*	15,6*	13,6*	13,6*	10,8*	10,8*									9,0*	9,0*
10						13,3	15,4*	8,9	11,9	5,9	8,3									3,9	6,0
5						15,4*	15,4*	13,4*	13,4*	11,8*	11,8*									8,4*	8,4*
0						12,8	15,6*	8,6	11,6	5,8	8,2	3,7	5,7							3,1	5,0
-5						15,6*	15,6*	13,4*	13,4*	11,7*	11,7*	10,3*	10,3*							8,1*	8,1*
-10				18,3	19,4*	11,9	15,8	8,0	11,0	5,4	7,8	3,6	5,6							2,5	4,3
				19,4*	19,4*	16,0*	16,0*	13,6*	13,6*	11,8*	11,8*	10,3*	10,3*							7,9*	7,9*
		23,2*	23,2*	16,3	20,6*	10,6	14,5	7,2	10,2	4,9	7,3	3,3	5,3							2,1	3,9
		23,2*	23,2*	20,6*	20,6*	16,7*	16,7*	13,9*	13,9*	11,9*	11,9*	10,0	10,2*							7,9	7,9*
		22,4	29,6*	13,8	19,2	9,2	13,0	6,3	9,3	4,4	6,7	3,0	5,0	1,9	3,6					1,9	3,6
		29,6*	29,6*	21,9*	21,9*	17,3*	17,3*	14,2*	14,2*	12,0*	12,0*	9,6	10,1*	7,6	7,9*					7,5	7,8*
		17,6	26,2	11,4	16,6	7,8	11,5	5,5	8,3	3,8	6,2	2,6	4,6	1,8	3,5					1,8	3,4
		31,6*	31,6*	22,9*	22,9*	17,8*	17,8*	14,4*	14,4*	11,7	11,9*	9,2	9,7*	7,2*	7,2*					7,0*	7,0*
		14,4	22,6	9,5	14,6	6,6	10,3	4,7	7,6	3,4	5,7	2,4	4,3							1,7	3,4
		25,0*	25,0*	22,9*	22,9*	17,7*	17,7*	14,1*	14,1*	11,2	11,4*	8,9	9,0*							6,0*	6,0*
		12,8	20,4*	8,3	13,3	5,8	9,4	4,2	7,0	3,0	5,3	2,2	4,1							1,9	3,7
		20,4*	20,4*	21,6*	21,6*	16,7*	16,7*	13,2*	13,2*	10,4*	10,4*	7,6*	7,6*							5,8*	5,8*
		12,3	20,2	7,8	12,7	5,4	8,9	3,9	6,7	2,9	5,1									2,5	4,6
		21,1*	21,1*	18,4*	18,4*	14,5*	14,5*	11,3*	11,3*	8,4*	8,4*									6,9*	6,9*

Height Can be slewed through 360° In longitudinal position of undercarriage Max. reach * Limited by hydr. capacity

The lift capacities on the stick end without attachment are stated in lb x 1,000 and are valid on a firm, level supporting surface with blocked oscillating axle. These capacities can be slewed through 360° with the undercarriage in the transverse position. Capacities in the longitudinal position of the undercarriage (+/- 15°) are specified over the steering axle with the stabilizers raised and over the rigid axle with the stabilizers down. Indicated loads based on the ISO 10567 standard and do not exceed 75% of tipping or 87% of hydraulic capacity. The lift capacity values indicated are attained at the corresponding operating temperature. This operating temperature is ensured by continuous movement of the boom. Weights of fitted working tools (grabs, load hooks, etc.) and load accommodation equipment are to be deducted from the lift capacity values. The lift capacity of the unit is limited by its stability, the lifting capability of the hydraulic elements, or the maximum permissible lifting capacity of the load hook.

LH 50 M - Attachment GA16

Industry – Kinematic 2A

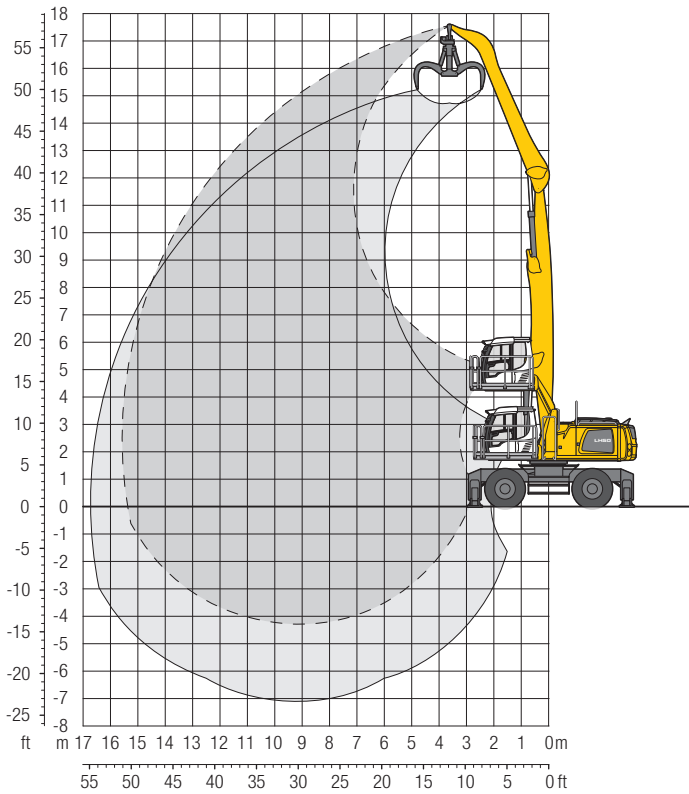

Operating Weight

The operating weight includes the basic machine with 4 point outriggers, hydr. cab elevation, 4 solid tires, straight boom 29'10", angled stick 22'4" and grab model GM 70C/ 1.44 yd³ semi-closed tines.

Weight 97,000 lb

Dimensions

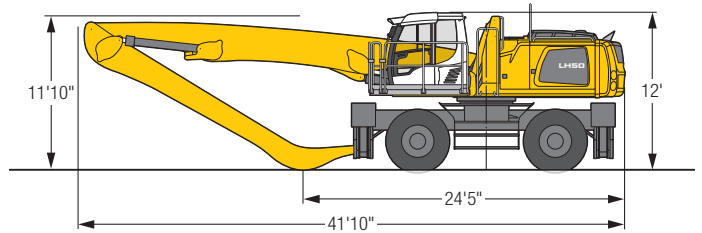

ft	Undercarriage	15 ft		20 ft		25 ft		30 ft		35 ft		40 ft		45 ft		50 ft		55 ft		ft in			
		Stabilizers raised	4 pt. outriggers down	Stabilizers raised	4 pt. outriggers down	Stabilizers raised	4 pt. outriggers down	Stabilizers raised	4 pt. outriggers down	Stabilizers raised	4 pt. outriggers down	Stabilizers raised	4 pt. outriggers down	Stabilizers raised	4 pt. outriggers down	Stabilizers raised	4 pt. outriggers down	Stabilizers raised	4 pt. outriggers down	Stabilizers raised	4 pt. outriggers down	ft in	
60	Stabilizers raised 4 pt. outriggers down																						
55	Stabilizers raised 4 pt. outriggers down			15,9*	15,9*																15,3*	15,3*	20' 6"
50	Stabilizers raised 4 pt. outriggers down					16,5*	16,5*														15,3*	15,3*	29' 6"
45	Stabilizers raised 4 pt. outriggers down					18,3	18,4*	13,4	16,2*	9,9	11,7*										9,6	10,8*	35' 6"
40	Stabilizers raised 4 pt. outriggers down					18,4*	18,4*	18,0*	18,0*	10,3	13,2	7,7	10,1								10,8*	10,8*	40' 1"
35	Stabilizers raised 4 pt. outriggers down					18,0*	18,0*	18,0*	18,0*	16,0*	16,0*	14,5*	14,5*	10,2*	10,2*						7,7	10,0*	43' 7"
30	Stabilizers raised 4 pt. outriggers down					18,0*	18,0*	18,0*	18,0*	13,6	15,9*	10,4	13,2	8,0	10,3						6,5	8,6	46' 4"
25	Stabilizers raised 4 pt. outriggers down					18,0*	18,0*	18,0*	18,0*	15,9*	15,9*	14,4*	14,4*	13,1*	13,1*						9,6*	9,6*	48' 4"
20	Stabilizers raised 4 pt. outriggers down					18,1	18,4*	18,4*	18,4*	16,1*	16,1*	14,5*	14,5*	13,1*	13,1*	6,2	8,2				5,7	7,7	49' 10"
15	Stabilizers raised 4 pt. outriggers down					18,4*	18,4*	18,4*	18,4*	16,1*	16,1*	14,5*	14,5*	13,1*	13,1*	11,6*	11,6*				9,3*	9,3*	50' 8"
10	Stabilizers raised 4 pt. outriggers down					22,5*	22,5*	22,5*	22,5*	19,0*	19,0*	16,5*	16,5*	14,7*	14,7*	13,2*	13,2*	12,0*	12,0*		5,2	7,0	51' 1"
5	Stabilizers raised 4 pt. outriggers down	22,9*	22,9*	23,2	24,0*	17,4	19,0*	12,9	16,5	9,9	12,7	7,8	10,1	6,1	8,1					9,1*	9,1*	51'	
0	Stabilizers raised 4 pt. outriggers down	22,9*	22,9*	24,0*	24,0*	16,4	19,9*	12,2	15,8	9,5	12,3	7,5	9,8	6,0	8,0					4,8	6,6	50' 5"	
-5	Stabilizers raised 4 pt. outriggers down	32,3	34,2*	21,0	25,9*	15,1	19,7	11,5	14,9	9,0	11,8	7,2	9,5	5,8	7,8	4,7	6,4			9,1*	9,1*	48'	
-10	Stabilizers raised 4 pt. outriggers down	34,2*	34,2*	25,9*	25,9*	21,0*	21,0*	17,7*	17,7*	15,4*	15,4*	13,6*	13,6*	12,0*	12,0*	10,4*	10,4*			4,6	6,3	42' 10"	
-15	Stabilizers raised 4 pt. outriggers down	27,6	31,4*	18,7	25,2	13,8	18,3	10,6	14,1	8,4	11,2	6,8	9,1	5,6	7,6	4,6	6,3			9,2*	9,2*		
	Stabilizers raised 4 pt. outriggers down	31,4*	31,4*	27,6*	27,6*	22,0*	22,0*	18,3*	18,3*	15,7*	15,7*	13,7*	13,7*	12,0*	12,0*	10,1*	10,1*			4,4	6,1		
	Stabilizers raised 4 pt. outriggers down	11,0*	11,0*	16,8	23,0	12,6	17,0	9,8	13,3	7,9	10,7	6,5	8,8	5,3	7,3	4,5	6,2			9,4*	9,4*		
	Stabilizers raised 4 pt. outriggers down	11,0*	11,0*	28,6*	28,6*	22,6*	22,6*	18,6*	18,6*	15,8*	15,8*	13,6*	13,6*	11,7*	11,7*	9,6*	9,6*			4,3	6,0		
	Stabilizers raised 4 pt. outriggers down	9,7*	9,7*	15,4	21,6	11,7	16,1	9,2	12,6	7,5	10,2	6,2	8,5	5,2	7,2	4,4	6,2			8,9*	8,9*		
	Stabilizers raised 4 pt. outriggers down	11,1*	11,1*	14,7	20,8	11,1	15,4	8,8	12,1	7,2	9,9	6,0	8,3	5,1	7,0					4,4	6,1		
	Stabilizers raised 4 pt. outriggers down	11,1*	11,1*	22,2*	22,2*	21,4*	21,4*	17,7*	17,7*	14,8*	14,8*	12,4*	12,4*	10,0*	10,0*					8,1*	8,1*		
	Stabilizers raised 4 pt. outriggers down	14,5	20,6	10,8	15,1	8,5	11,9	7,0	9,7	5,9	8,2									4,6	6,5		
	Stabilizers raised 4 pt. outriggers down	22,5*	22,5*	19,0*	19,0*	15,9*	15,9*	13,2*	13,2*	10,7*	10,7*									8,2*	8,2*		
	Stabilizers raised 4 pt. outriggers down																			5,4	7,5		
	Stabilizers raised 4 pt. outriggers down																			9,3*	9,3*		

Height Can be slewed through 360° In longitudinal position of undercarriage Max. reach * Limited by hydr. capacity

The lift capacities on the stick end without attachment are stated in lb x 1,000 and are valid on a firm, level supporting surface with blocked oscillating axle. These capacities can be slewed through 360° with the undercarriage in the transverse position. Capacities in the longitudinal position of the undercarriage (+/- 15°) are specified over the steering axle with the stabilizers raised and over the rigid axle with the stabilizers down. Indicated loads based on the ISO 10567 standard and do not exceed 75% of tipping or 87% of hydraulic capacity. The lift capacity values indicated are attained at the corresponding operating temperature. This operating temperature is ensured by continuous movement of the boom. Weights of fitted working tools (grabs, load hooks, etc.) and load accommodation equipment are to be deducted from the lift capacity values. The lift capacity of the unit is limited by its stability, the lifting capability of the hydraulic elements, or the maximum permissible lifting capacity of the load hook.

LH 50 M - Attachment GA17

Industry – Kinematic 2A

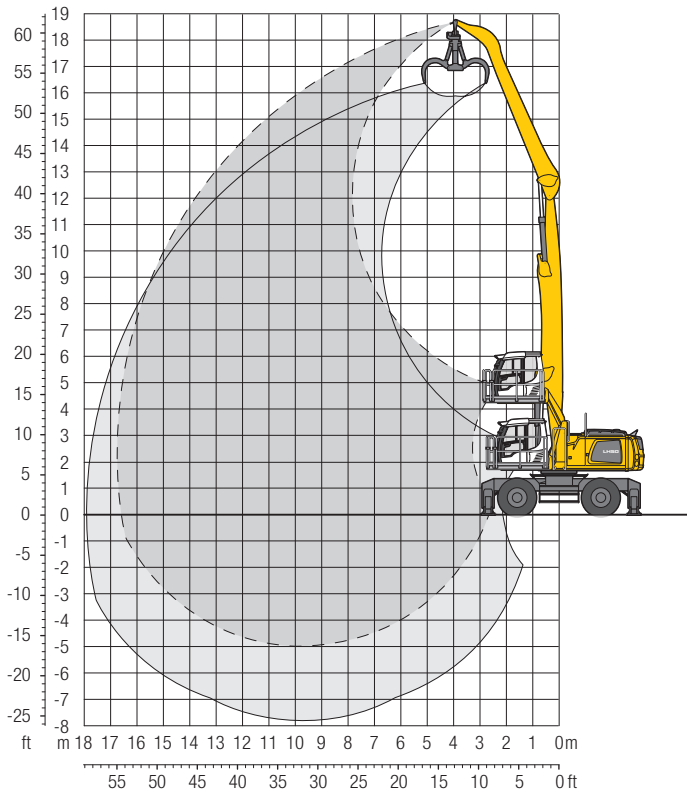

Operating Weight

The operating weight includes the basic machine with 4 point outriggers, hydr. cab elevation, 4 solid tires, straight boom 31'6", angled stick 24'7" and grab model GM 70C / 1.05 yd³ semi-closed tines.

Weight 97,400 lb

Dimensions

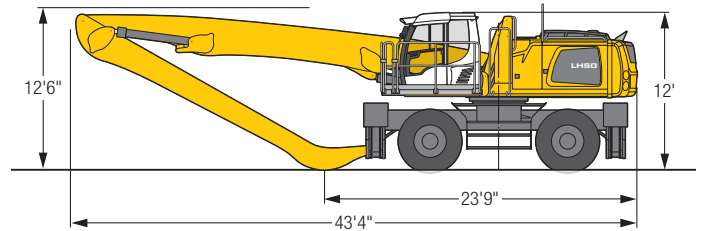

ft	Undercarriage	15 ft		20 ft		25 ft		30 ft		35 ft		40 ft		45 ft		50 ft		55 ft		ft in						
		Stabilizers raised	4 pt. outriggers down	Stabilizers raised	4 pt. outriggers down	Stabilizers raised	4 pt. outriggers down	Stabilizers raised	4 pt. outriggers down	Stabilizers raised	4 pt. outriggers down	Stabilizers raised	4 pt. outriggers down	Stabilizers raised	4 pt. outriggers down	Stabilizers raised	4 pt. outriggers down	Stabilizers raised	4 pt. outriggers down	Stabilizers raised	4 pt. outriggers down	ft	in			
60	Stabilizers raised																				15,4"	15,4"	18'	5"		
	4 pt. outriggers down																					15,4"	15,4"			
55	Stabilizers raised					15,0"	15,0"															11,7"	11,7"	28'	11"	
	4 pt. outriggers down					15,0"	15,0"															11,7"	11,7"			
50	Stabilizers raised					16,9"	16,9"	13,6	14,8"	10,0	11,1"											9,5	10,1"	35'	10"	
	4 pt. outriggers down					16,9"	16,9"	14,8"	14,8"	11,1"	11,1"											10,1"	10,1"			
45	Stabilizers raised							14,0	15,3"	10,5	13,4		7,9	10,2								7,4	9,3"	40'	11"	
	4 pt. outriggers down							15,3"	15,3"	13,8"	13,8"	10,5"	10,5"									9,3"	9,3"			
40	Stabilizers raised							14,1	15,1"	10,7	13,5		8,2	10,5								6,2	8,2	44'	11"	
	4 pt. outriggers down							15,1"	15,1"	13,6"	13,6"	12,4"	12,4"									8,7"	8,7"			
35	Stabilizers raised							14,0	15,2"	10,6	13,5		8,2	10,6	6,3	8,4						5,3	7,2	48'	1"	
	4 pt. outriggers down							15,2"	15,2"	13,6"	13,6"	12,4"	12,4"		11,4"	11,4"						8,4"	8,4"			
30	Stabilizers raised					17,6"	17,6"	13,6	15,4"	10,4	13,3		8,1	10,4	6,3	8,3	4,9	6,6				4,7	6,5	50'	6"	
	4 pt. outriggers down					17,6"	17,6"	15,4"	15,4"	13,8"	13,8"	12,4"	12,4"		11,3"	11,3"	9,1"	9,1"				8,2"	8,2"			
25	Stabilizers raised					17,7	18,3"	13,1	15,8"	10,0	12,9		7,8	10,2	6,2	8,2	4,9	6,6				4,3	6,0	52'	5"	
	4 pt. outriggers down					18,3"	18,3"	15,8"	15,8"	14,0"	14,0"	12,6"	12,6"	11,4"	11,4"	10,3"	10,3"						8,1"	8,1"		
20	Stabilizers raised			22,9"	22,9"	16,5	19,2"	12,3	15,9	9,5	12,3		7,5	9,8	6,0	8,0	4,8	6,5				4,0	5,6	53'	8"	
	4 pt. outriggers down			22,9"	22,9"	19,2"	19,2"	16,4"	16,4"	14,4"	14,4"	12,8"	12,8"	11,5"	11,5"	10,3"	10,3"						8,1"	8,1"		
15	Stabilizers raised	32,7	33,0"	21,2	25,0"	15,1	19,7	11,4	14,9	8,9	11,7		7,1	9,4	5,7	7,7	4,6	6,4				3,8	5,4	54'	7"	
	4 pt. outriggers down	33,0"	33,0"	25,0"	25,0"	20,2"	20,2"	17,0"	17,0"	14,7"	14,7"	13,0"	13,0"	11,6"	11,6"	10,3"	10,3"						8,1"	8,1"		
10	Stabilizers raised	27,5	33,3"	18,6	25,1	13,6	18,2	10,5	13,9	8,3	11,1		6,6	9,0	5,4	7,4	4,4	6,2				3,6	5,2	54'	11"	
	4 pt. outriggers down	33,3"	33,3"	26,7"	26,7"	21,2"	21,2"	17,6"	17,6"	15,1"	15,1"	13,1"	13,1"	11,6"	11,6"	10,2"	10,2"						8,3"	8,3"		
5	Stabilizers raised	9,6"	9,6"	16,4	22,6	12,3	16,7	9,6	13,0	7,7	10,4		6,2	8,6	5,1	7,1	4,3	6,0				3,6	5,2	54'	10"	
	4 pt. outriggers down	9,6"	9,6"	27,7"	27,7"	21,8"	21,8"	18,0"	18,0"	15,3"	15,3"	13,2"	13,2"	11,5"	11,5"	9,9"	9,9"						7,9"	7,9"		
0	Stabilizers raised	8,2"	8,2"	14,8	21,0	11,2	15,6	8,9	12,2	7,2	9,9		5,9	8,2	4,9	6,9	4,1	5,9				3,6	5,2	54'	4"	
	4 pt. outriggers down	8,2"	8,2"	21,5"	21,5"	21,9"	21,9"	18,0"	18,0"	15,2"	15,2"	13,0"	13,0"	11,1"	11,1"	9,3"	9,3"						7,2"	7,2"		
-5	Stabilizers raised	9,2"	9,2"	14,0	18,3"	10,5	14,9	8,3	11,7	6,8	9,5		5,6	7,9	4,7	6,7	4,0	5,8				3,8	5,4	52'	6"	
	4 pt. outriggers down	9,2"	9,2"	18,3"	18,3"	21,1"	21,1"	17,4"	17,4"	14,6"	14,6"	12,4"	12,4"	10,4"	10,4"	8,4"	8,4"						7,0"	7,0"		
-10	Stabilizers raised			13,6	18,4"	10,1	14,5	8,0	11,4	6,5	9,3		5,5	7,7	4,6	6,6						4,2	6,1	48'	1"	
	4 pt. outriggers down			18,4"	18,4"	19,2"	19,2"	16,1"	16,1"	13,5"	13,5"	11,3"	11,3"	9,2"	9,2"								7,7"	7,7"		
-15	Stabilizers raised					10,0	14,3	7,9	11,2	6,5	9,2											5,5	7,9	39'	4"	
	4 pt. outriggers down					16,1"	16,1"	13,7"	13,7"	11,5"	11,5"											9,7"	9,7"			

Height **Can be slewed through 360°** **In longitudinal position of undercarriage** **Max. reach** *** Limited by hydr. capacity**

The lift capacities on the stick end without attachment are stated in lb x 1,000 and are valid on a firm, level supporting surface with blocked oscillating axle. These capacities can be slewed through 360° with the undercarriage in the transverse position. Capacities in the longitudinal position of the undercarriage (+/- 15°) are specified over the steering axle with the stabilizers raised and over the rigid axle with the stabilizers down. Indicated loads based on the ISO 10567 standard and do not exceed 75% of tipping or 87% of hydraulic capacity. The lift capacity values indicated are attained at the corresponding operating temperature. This operating temperature is ensured by continuous movement of the boom. Weights of fitted working tools (grabs, load hooks, etc.) and load accommodation equipment are to be deducted from the lift capacity values. The lift capacity of the unit is limited by its stability, the lifting capability of the hydraulic elements, or the maximum permissible lifting capacity of the load hook.

LH 50 M - Attachment GA18

Industry – Kinematic 2A

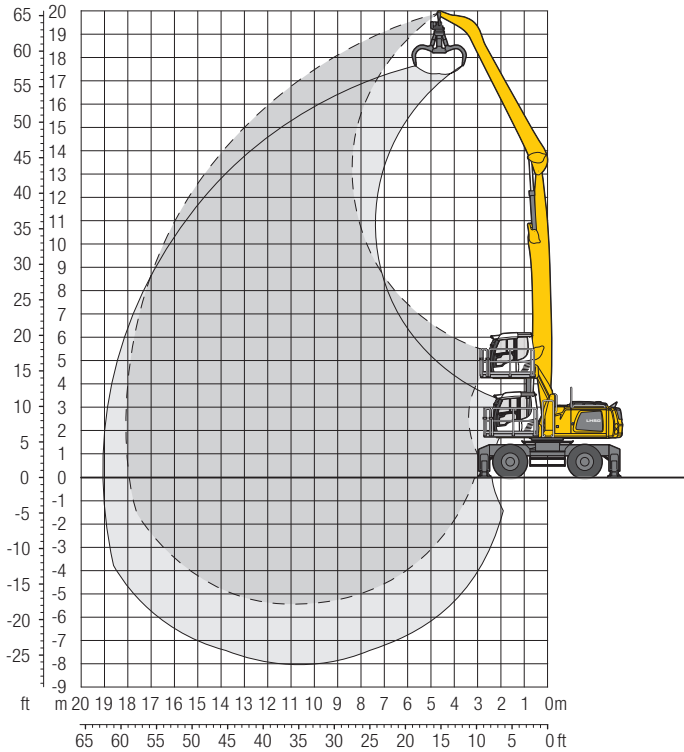

Operating Weight

The operating weight includes the basic machine with 4 point outriggers, hydr. cab elevation, 4 solid tires, straight boom 34'9", angled stick 26'3" and grab model GM 65/ 0.78 yd³ semi-closed tines.

Weight 98,100 lb

Dimensions

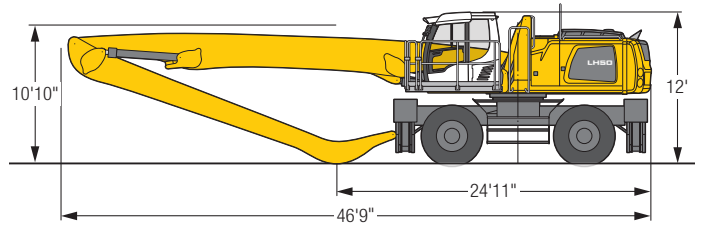

ft	Undercarriage	15 ft	20 ft	25 ft	30 ft	35 ft	40 ft	45 ft	50 ft	55 ft	ft in	
65	Stabilizers raised 4 pt. outriggers down										14,5* 14,5* 14,5* 14,5*	16'11"
60	Stabilizers raised 4 pt. outriggers down			13,4* 13,4* 13,4* 13,4*							10,8* 10,8* 10,8* 10,8*	28'11"
55	Stabilizers raised 4 pt. outriggers down			15,3* 15,3* 15,3* 15,3*	13,4* 13,4* 13,4* 13,4*	10,0 10,6* 10,6* 10,6*					9,1 9,3* 9,3* 9,3*	36' 6"
50	Stabilizers raised 4 pt. outriggers down				14,2 14,6* 14,6* 14,6*	10,6 12,9* 12,9* 12,9*	7,9 10,3 10,4* 10,4*				6,9 8,5* 8,5* 8,5*	42' 1"
45	Stabilizers raised 4 pt. outriggers down				14,4 14,4* 14,4* 14,4*	10,8 12,7* 12,7* 12,7*	8,2 10,6 11,4* 11,4*	6,1 8,2 9,6* 9,6*			5,5 7,5 8,0* 8,0*	46' 7"
40	Stabilizers raised 4 pt. outriggers down				14,3 14,4* 14,4* 14,4*	10,8 12,7* 12,7* 12,7*	8,2 10,6 11,4* 11,4*	6,3 8,3 10,3* 10,3*	4,6 6,4 7,8* 7,8*		4,6 6,4 7,7* 7,7*	50' 1"
35	Stabilizers raised 4 pt. outriggers down				14,0 14,5* 14,5* 14,5*	10,5 12,8* 12,8* 12,8*	8,1 10,5 11,4* 11,4*	6,2 8,3 10,3* 10,3*	4,7 6,5 9,4* 9,4*		4,0 5,6 7,4* 7,4*	53'
30	Stabilizers raised 4 pt. outriggers down			17,2* 17,2* 17,2* 17,2*	13,5 14,8* 14,8* 14,8*	10,2 12,9* 12,9* 12,9*	7,8 10,2 11,5* 11,5*	6,1 8,1 10,3* 10,3*	4,7 6,5 9,4* 9,4*	3,5 5,1 7,6* 7,6*	3,5 5,0 7,3* 7,3*	55' 2"
25	Stabilizers raised 4 pt. outriggers down			17,3 17,8* 17,8* 17,8*	12,7 15,1* 15,1* 15,1*	9,6 12,5 13,1* 13,1*	7,4 9,8 11,6* 11,6*	5,8 7,8 10,4* 10,4*	4,5 6,3 9,4* 9,4*	3,5 5,1 8,4* 8,4*	3,1 4,6 7,3* 7,3*	56'11"
20	Stabilizers raised 4 pt. outriggers down	21,1* 21,1* 21,1* 21,1*	22,7 22,8* 22,8* 22,8*	15,8 18,5* 18,5* 18,5*	11,7 15,3 15,6* 15,6*	8,9 11,8 13,4* 13,4*	7,0 9,3 11,8* 11,8*	5,5 7,5 10,5* 10,5*	4,3 6,1 9,4* 9,4*	3,4 4,9 8,4* 8,4*	2,8 4,3 7,3* 7,3*	58' 1"
15	Stabilizers raised 4 pt. outriggers down	30,2 32,5* 32,5* 32,5*	19,7 24,2* 24,2* 24,2*	14,1 18,7 19,3* 19,3*	10,6 14,1 16,0* 16,0*	8,2 11,0 13,7* 13,7*	6,4 8,8 12,0* 12,0*	5,1 7,1 10,6* 10,6*	4,1 5,8 9,4* 9,4*	3,2 4,8 8,3* 8,3*	2,6 4,1 7,3* 7,3*	58'11"
10	Stabilizers raised 4 pt. outriggers down	13,0* 13,0* 13,0* 13,0*	16,6 23,0 25,3* 25,3*	12,3 16,8 19,9* 19,9*	9,4 12,9 16,4* 16,4*	7,4 10,2 13,9* 13,9*	5,9 8,2 12,1* 12,1*	4,7 6,7 10,6* 10,6*	3,8 5,6 9,3* 9,3*	3,1 4,6 8,1* 8,1*	2,5 4,0 6,9* 6,9*	59' 2"
5	Stabilizers raised 4 pt. outriggers down	6,2* 6,2* 6,2* 6,2*	14,1 20,3 21,1* 21,1*	10,7 15,1 20,2* 20,2*	8,4 11,8 16,6* 16,6*	6,7 9,4 14,0* 14,0*	5,4 7,7 12,1* 12,1*	4,4 6,4 10,5* 10,5*	3,6 5,3 9,1* 9,1*	2,9 4,5 7,8* 7,8*	2,4 3,9 6,5* 6,5*	59' 2"
0	Stabilizers raised 4 pt. outriggers down	5,9* 5,9* 5,9* 5,9*	12,4 14,2* 14,2* 14,2*	9,5 13,8 20,0* 20,0*	7,5 10,9 16,5* 16,5*	6,1 8,8 13,9* 13,9*	4,9 7,2 11,9* 11,9*	4,1 6,0 10,2* 10,2*	3,3 5,1 8,8* 8,8*	2,8 4,3 7,3* 7,3*	2,4 3,9 5,9* 5,9*	58' 8"
-5	Stabilizers raised 4 pt. outriggers down	7,0* 7,0* 7,0* 7,0*	11,5 13,1* 13,1* 13,1*	8,7 13,0 19,1* 19,1*	6,9 10,2 15,8* 15,8*	5,6 8,3 13,3* 13,3*	4,6 6,9 11,4* 11,4*	3,8 5,8 9,7* 9,7*	3,2 4,9 8,2* 8,2*	2,7 4,2 6,5* 6,5*	2,5 4,0 5,2* 5,2*	57' 8"
-10	Stabilizers raised 4 pt. outriggers down		11,2 13,6* 13,6* 13,6*	8,3 12,5 17,2* 17,2*	6,5 9,8 14,6* 14,6*	5,3 8,0 12,4* 12,4*	4,4 6,6 10,5* 10,5*	3,6 5,6 8,8* 8,8*	3,1 4,8 7,2* 7,2*		2,7 4,3 5,7* 5,7*	53'10"
-15	Stabilizers raised 4 pt. outriggers down			8,2 12,4 14,5* 14,5*	6,3 9,7 12,6* 12,6*	5,1 7,8 10,7* 10,7*	4,2 6,5 9,0* 9,0*	3,6 5,6 7,4* 7,4*			3,4 5,2 6,7* 6,7*	46'11"

Height
 Can be slewed through 360°
 In longitudinal position of undercarriage
 Max. reach
 * Limited by hydr. capacity

The lift capacities on the stick end without attachment are stated in lb x 1,000 and are valid on a firm, level supporting surface with blocked oscillating axle. These capacities can be slewed through 360° with the undercarriage in the transverse position. Capacities in the longitudinal position of the undercarriage (+/- 15°) are specified over the steering axle with the stabilizers raised and over the rigid axle with the stabilizers down. Indicated loads based on the ISO 10567 standard and do not exceed 75% of tipping or 87% of hydraulic capacity. The lift capacity values indicated are attained at the corresponding operating temperature. This operating temperature is ensured by continuous movement of the boom. Weights of fitted working tools (grabs, load hooks, etc.) and load accommodation equipment are to be deducted from the lift capacity values. The lift capacity of the unit is limited by its stability, the lifting capability of the hydraulic elements, or the maximum permissible lifting capacity of the load hook.

LH 50 M - Attachment AF16

Industry – Kinematic 2D

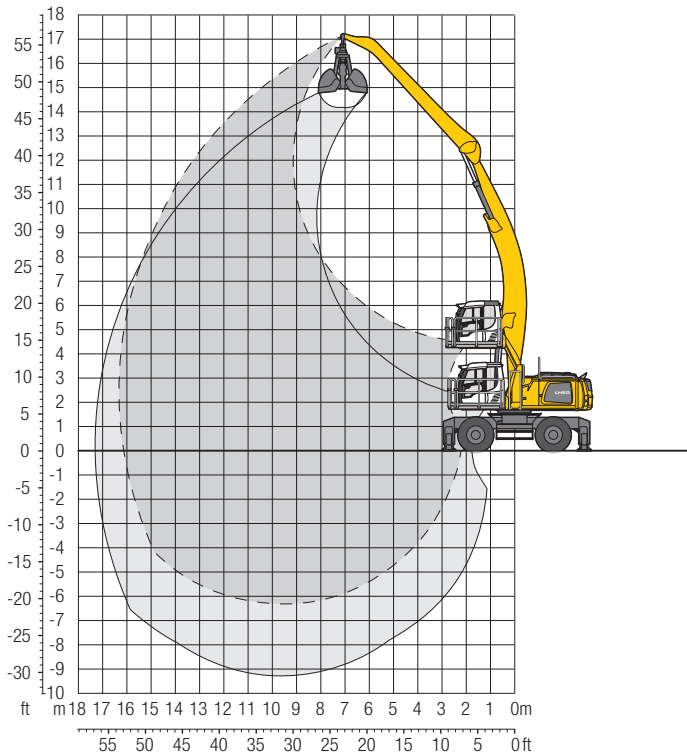

Operating Weight

The operating weight includes the basic machine with 4 point outriggers, hydr. cab elevation, 4 solid tires, angled boom 31'6", flat angled stick 24'7" and grab model GM 20C/1.96 yd³ shells for loose material.

Weight 98,100 lb

Dimensions

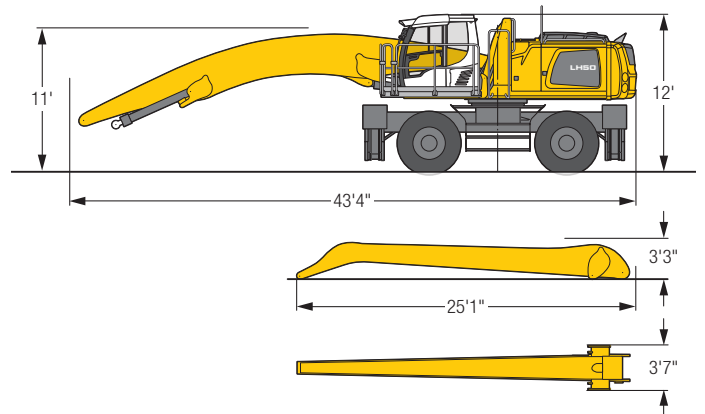

ft	Undercarriage	15 ft		20 ft		25 ft		30 ft		35 ft		40 ft		45 ft		50 ft		55 ft		ft in		
		Stabilizers raised	4 pt. outriggers down	Stabilizers raised	4 pt. outriggers down	Stabilizers raised	4 pt. outriggers down	Stabilizers raised	4 pt. outriggers down	Stabilizers raised	4 pt. outriggers down	Stabilizers raised	4 pt. outriggers down	Stabilizers raised	4 pt. outriggers down	Stabilizers raised	4 pt. outriggers down	Stabilizers raised	4 pt. outriggers down	Stabilizers raised	4 pt. outriggers down	ft in
60	Stabilizers raised																					
60	4 pt. outriggers down																					
55	Stabilizers raised					11,3*	11,3*													10,9*	10,9*	25' 5"
55	4 pt. outriggers down					11,3*	11,3*													10,9*	10,9*	
50	Stabilizers raised							11,9*	11,9*											9,5*	9,5*	33' 1"
50	4 pt. outriggers down							11,9*	11,9*											9,5*	9,5*	
45	Stabilizers raised							13,2*	13,2*	10,9	11,7*									8,8*	8,8*	38' 7"
45	4 pt. outriggers down							13,2*	13,2*	11,7*	11,7*									8,8*	8,8*	
40	Stabilizers raised							13,0*	13,0*	11,1	11,9*									7,2	8,4*	42'10"
40	4 pt. outriggers down							13,0*	13,0*	11,9*	11,9*	8,4	10,9							8,4*	8,4*	
35	Stabilizers raised							13,1*	13,1*	11,0	11,9*			6,5	8,6					6,1	8,1	46' 1"
35	4 pt. outriggers down							13,1*	13,1*	11,9*	11,9*	8,5	10,9	9,4*	9,4*					8,2*	8,2*	
30	Stabilizers raised							13,3*	13,3*	10,8	12,0*			6,5	8,5					5,3	7,2	48' 8"
30	4 pt. outriggers down							13,3*	13,3*	12,0*	12,0*	8,3	10,7	10,2*	10,2*					8,1*	8,1*	
25	Stabilizers raised							13,6	13,8*	10,4	12,3*			6,3	8,4	4,9	6,7			4,8	6,5	50' 7"
25	4 pt. outriggers down							13,8*	13,8*	12,3*	12,3*	8,1	10,5	10,2*	10,2*	8,9*	8,9*			8,1*	8,1*	
20	Stabilizers raised					16,7*	16,7*	12,8	14,4*	9,8	12,7			6,1	8,1	4,8	6,6			4,4	6,1	52'
20	4 pt. outriggers down					16,7*	16,7*	14,4*	14,4*	12,7*	12,7*	7,7	10,1	10,4*	10,4*	9,5*	9,5*			8,2*	8,2*	
15	Stabilizers raised	28,8*	28,8*	21,9*	21,9*	15,7	17,8*	11,8	15,1*	9,1	12,0			5,8	7,8	4,6	6,4			4,1	5,7	52'10"
15	4 pt. outriggers down	28,8*	28,8*	21,9*	21,9*	17,8*	17,8*	15,1*	15,1*	13,2*	13,2*	7,2	9,6	10,6*	10,6*	9,6*	9,6*			8,3*	8,3*	
10	Stabilizers raised	28,3	32,5*	19,1	23,8*	14,0	18,6	10,7	14,2	8,5	11,3			5,5	7,5	4,4	6,2			3,9	5,5	53' 2"
10	4 pt. outriggers down	32,5*	32,5*	23,8*	23,8*	18,9*	18,9*	15,8*	15,8*	13,6*	13,6*	12,0*	12,0*	10,7*	10,7*	9,6*	9,6*			8,6*	8,6*	
5	Stabilizers raised	15,3*	15,3*	16,7	23,0	12,5	17,0	9,7	13,2	7,8	10,6			5,1	7,2	4,2	6,0			3,7	5,4	53' 1"
5	4 pt. outriggers down	15,3*	15,3*	25,4*	25,4*	19,9*	19,9*	16,4*	16,4*	14,0*	14,0*	6,3	8,6	10,8*	10,8*	9,6*	9,6*			8,8*	8,8*	
0	Stabilizers raised	11,9*	11,9*	14,9	21,1	11,3	15,7	8,9	12,3	7,2	10,0			4,9	6,9	4,0	5,8			3,7	5,3	52' 7"
0	4 pt. outriggers down	11,9*	11,9*	26,1*	26,1*	20,5*	20,5*	16,8*	16,8*	14,3*	14,3*	5,9	8,2	10,8*	10,8*	9,4*	9,4*			8,6*	8,6*	
-5	Stabilizers raised	12,0*	12,0*	13,8	19,9	10,4	14,8	8,3	11,6	6,7	9,5			4,6	6,6	3,9	5,7			3,7	5,4	51' 6"
-5	4 pt. outriggers down	12,0*	12,0*	21,5*	21,5*	20,5*	20,5*	16,8*	16,8*	14,2*	14,2*	5,5	7,9	10,5*	10,5*	8,9*	8,9*			8,4*	8,4*	
-10	Stabilizers raised	13,0*	13,0*			9,9	14,3	7,8	11,2	6,4	9,1			4,5	6,5					3,9	5,6	49'11"
-10	4 pt. outriggers down	13,0*	13,0*			19,8*	19,8*	16,4*	16,4*	13,8*	13,8*	5,3	7,6	9,9*	9,9*					8,0*	8,0*	
-15	Stabilizers raised			13,1	19,1	9,7	14,0	7,6	11,0	6,2	9,0			4,4	6,4					4,2	6,1	47' 1"
-15	4 pt. outriggers down			20,9*	20,9*	18,2*	18,2*	15,2*	15,2*	12,8*	12,8*	5,2	7,5	10,7*	10,7*					7,8*	7,8*	
-20	Stabilizers raised							7,6	11,0	6,2	9,0									5,9	8,4	36' 7"
-20	4 pt. outriggers down							13,2*	13,2*	11,0*	11,0*									10,3*	10,3*	

Height
 Can be slewed through 360°
 In longitudinal position of undercarriage
 Max. reach
 * Limited by hydr. capacity

The lift capacities on the stick end without attachment are stated in lb x 1,000 and are valid on a firm, level supporting surface with blocked oscillating axle. These capacities can be slewed through 360° with the undercarriage in the transverse position. Capacities in the longitudinal position of the undercarriage (+/- 15°) are specified over the steering axle with the stabilizers raised and over the rigid axle with the stabilizers down. Indicated loads based on the ISO 10567 standard and do not exceed 75% of tipping or 87% of hydraulic capacity. The lift capacity values indicated are attained at the corresponding operating temperature. This operating temperature is ensured by continuous movement of the boom. Weights of fitted working tools (grabs, load hooks, etc.) and load accommodation equipment are to be deducted from the lift capacity values. The lift capacity of the unit is limited by its stability, the lifting capability of the hydraulic elements, or the maximum permissible lifting capacity of the load hook.

LH 50 M - Attachment GA13

Industry – Kinematic 2A

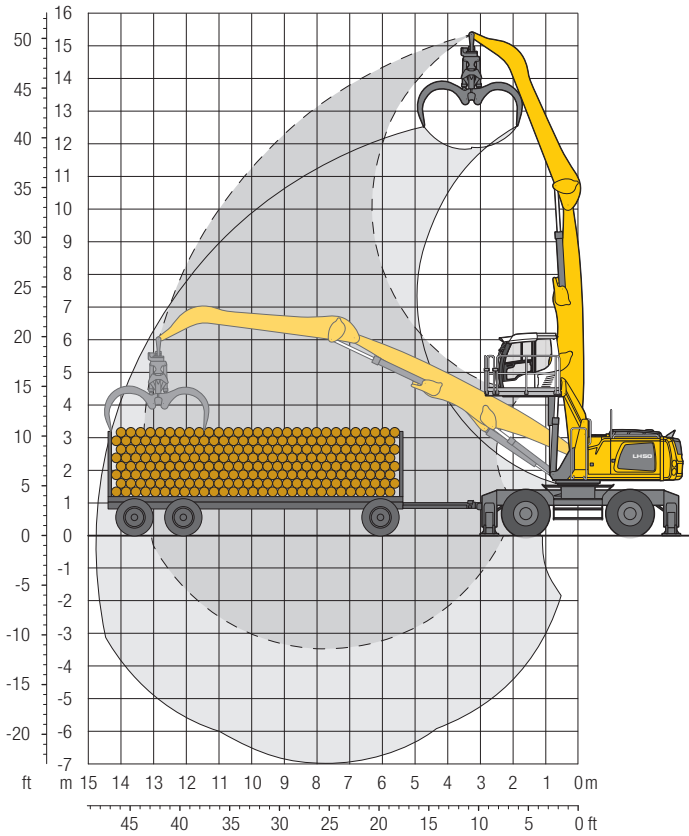

Operating Weight

The operating weight includes the basic machine with 4 point outriggers, hydr. cab elevation, 4 solid tires, straight boom 24'11", angled stick 19'8" and wood grab model GM 20B/2.27 yd³.

Weight 96,100 lb

Dimensions

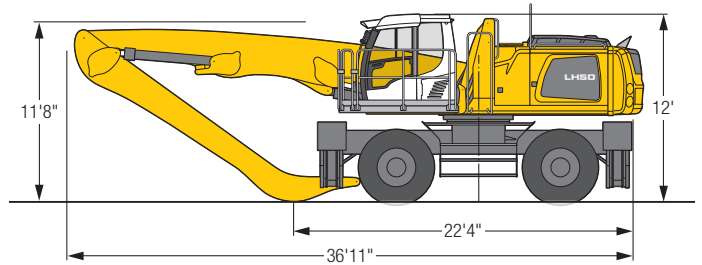

ft	Undercarriage	15 ft		20 ft		25 ft		30 ft		35 ft		40 ft		45 ft		50 ft		55 ft		ft in		
		Stabilizers raised	4 pt. outriggers down	Stabilizers raised	4 pt. outriggers down	Stabilizers raised	4 pt. outriggers down	Stabilizers raised	4 pt. outriggers down	Stabilizers raised	4 pt. outriggers down	Stabilizers raised	4 pt. outriggers down	Stabilizers raised	4 pt. outriggers down	Stabilizers raised	4 pt. outriggers down	Stabilizers raised	4 pt. outriggers down	Stabilizers raised	4 pt. outriggers down	Stabilizers raised
50																				21,1"	21,1"	12' 8"
45				19,3"	19,3"															14,7"	14,7"	23' 7"
40				21,9"	21,9"	17,6"	18,9"	12,7"	12,8"											12,6"	12,6"	30' 1"
35				21,9"	21,9"	17,9"	19,6"	13,2"	16,7"											10,1"	11,6"	34' 7"
30						17,8"	19,6"	13,2"	16,8"	10,1"	12,9"									8,6"	11,0"	38'
25				23,0"	23,0"	17,5"	20,0"	13,0"	16,5"	10,0"	12,8"	7,8"	10,2"							7,7"	10,0"	40' 5"
20				23,7"	24,5"	16,8"	21,0"	12,6"	16,1"	9,8"	12,6"	7,8"	10,1"							10,7"	10,7"	42' 1"
15				24,5"	24,5"	21,0"	21,0"	18,4"	18,4"	16,5"	16,5"	14,8"	14,8"							7,1"	9,2"	42' 1"
10				34,0"	34,0"	22,2"	26,6"	15,9"	20,5"	12,1"	15,6"	9,5"	12,3"	7,6"	10,0"					6,7"	8,8"	43' 2"
5				34,0"	34,0"	26,6"	26,6"	22,1"	22,1"	19,1"	19,1"	16,8"	16,8"	14,8"	14,8"					10,6"	10,6"	43' 8"
0				30,8"	38,5"	20,5"	27,0"	15,0"	19,5"	11,5"	15,0"	9,2"	11,9"	7,5"	9,8"					6,5"	8,5"	43' 8"
-5				38,5"	38,5"	28,9"	28,9"	23,4"	23,4"	19,7"	19,7"	17,0"	17,0"	14,8"	14,8"					10,9"	10,9"	43' 8"
-10				27,8"	33,8"	18,9"	25,3"	14,1"	18,5"	11,0"	14,4"	8,8"	11,6"	7,3"	9,6"					6,4"	8,5"	43' 6"
				33,8"	33,8"	30,6"	30,6"	24,3"	24,3"	20,1"	20,1"	17,1"	17,1"	14,4"	14,4"					11,3"	11,3"	43' 6"
				21,3"	21,3"	17,8"	24,1"	13,4"	17,8"	10,5"	13,9"	8,5"	11,3"	7,1"	9,4"					6,5"	8,6"	42' 11"
				21,3"	21,3"	30,8"	30,8"	24,3"	24,3"	19,9"	19,9"	16,6"	16,6"	13,4"	13,4"					10,8"	10,8"	42' 11"
				20,8"	20,8"	17,2"	23,4"	12,9"	17,3"	10,2"	13,6"	8,4"	11,1"							7,2"	9,5"	39' 8"
				20,8"	20,8"	28,9"	28,9"	23,1"	23,1"	18,7"	18,7"	15,1"	15,1"							11,5"	11,5"	39' 8"
				17,0"	23,2"	12,7"	17,1"	10,1"	13,5"											9,3"	12,4"	32' 1"
				24,6"	24,6"	20,0"	20,0"	16,0"	16,0"											14,4"	14,4"	32' 1"

Height **Can be slewed through 360°** **In longitudinal position of undercarriage** **Max. reach** * Limited by hydr. capacity

The lift capacities on the stick end without attachment are stated in lb x 1,000 and are valid on a firm, level supporting surface with blocked oscillating axle. These capacities can be slewed through 360° with the undercarriage in the transverse position. Capacities in the longitudinal position of the undercarriage (+/- 15°) are specified over the steering axle with the stabilizers raised and over the rigid axle with the stabilizers down. Indicated loads based on the ISO 10567 standard and do not exceed 75% of tipping or 87% of hydraulic capacity. The lift capacity values indicated are attained at the corresponding operating temperature. This operating temperature is ensured by continuous movement of the boom. Weights of fitted working tools (grabs, load hooks, etc.) and load accommodation equipment are to be deducted from the lift capacity values. The lift capacity of the unit is limited by its stability, the lifting capability of the hydraulic elements, or the maximum permissible lifting capacity of the load hook.

LH 50 M - Attachment GKG14

Industry – Kinematic 2A

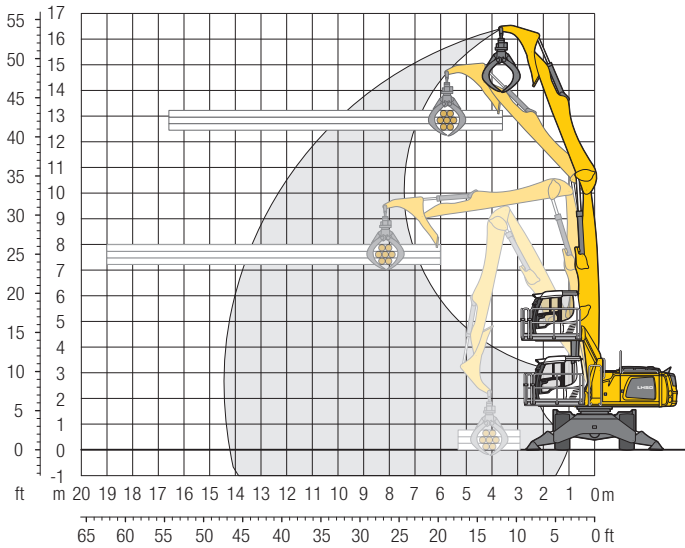

Operating Weight

The operating weight includes the basic machine with 4 point outriggers, hydr. cab elevation, 4 solid tires, straight boom 24'11", stick 19' with counterstay and wood grab 0.84 yd².

Weight	95,700 lb
--------	-----------

Dimensions

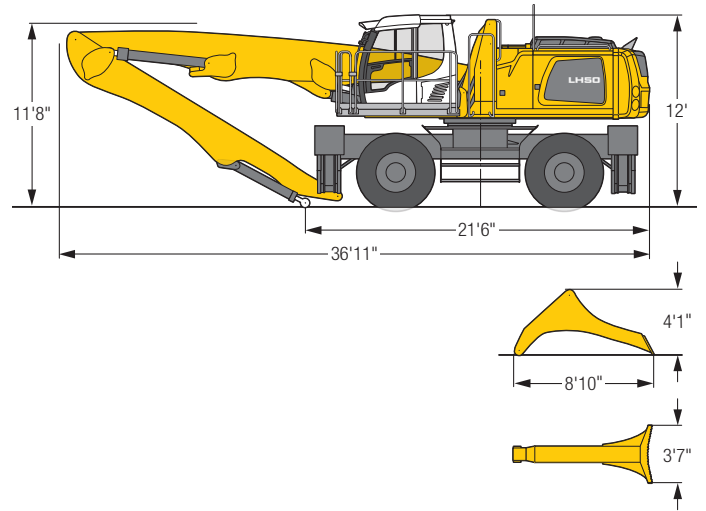

ft	15 ft		20 ft		25 ft		30 ft		35 ft		40 ft		45 ft		50 ft		55 ft		ft in		
	Stabilizers raised	4 pt. outriggers down	Stabilizers raised	4 pt. outriggers down	Stabilizers raised	4 pt. outriggers down	Stabilizers raised	4 pt. outriggers down	Stabilizers raised	4 pt. outriggers down	Stabilizers raised	4 pt. outriggers down	Stabilizers raised	4 pt. outriggers down	Stabilizers raised	4 pt. outriggers down	Stabilizers raised	4 pt. outriggers down	Stabilizers raised	4 pt. outriggers down	
50			15,7*	15,7*															13,0*	13,0*	22' 5"
45					15,5*	15,5*													10,5*	10,5*	30'
40					17,3*	17,3*	12,8	14,8*	9,3	9,6*									9,1	9,2*	35' 2"
35					16,9*	16,9*	13,0	15,4*	9,6	12,5									7,4	8,5*	39' 2"
30					16,9*	16,9*	13,0	15,3*	9,7	12,5	7,3	9,6							6,4	8,1*	42' 2"
25					17,4*	17,4*	12,7	15,6*	9,5	12,4	7,2	9,6							5,6	7,7	44' 5"
20					16,7	18,2*	12,2	15,8	9,2	12,0	7,1	9,4	5,4	7,4					5,2	7,1	45'11"
15			22,6	23,1*	15,7	19,4*	11,6	15,1	8,8	11,6	6,8	9,2	5,3	7,3					4,8	6,7	46'11"
10	32,2	33,4*	20,6	25,5*	14,6	19,1	10,8	14,3	8,3	11,1	6,5	8,9	5,2	7,2					7,7*	7,7*	47' 5"
5	28,1	37,6*	18,6	25,0	13,4	17,9	10,1	13,5	7,9	10,6	6,2	8,6	5,0	7,0					4,6	6,5	47' 4"
0	25,2	28,4*	16,9	23,2	12,4	16,8	9,5	12,9	7,4	10,2	6,0	8,3	4,9	6,9					8,1*	8,1*	46' 7"
-5	21,3*	21,3*	15,8	22,0	11,6	16,0	9,0	12,4	7,1	9,9	5,8	8,1							5,0	7,0	44' 5"
-10	21,3*	21,3*	15,3	21,4	11,2	15,6	8,7	12,1	7,0	9,7									5,8	8,2	39' 7"

Height
 Can be slewed through 360°
 In longitudinal position of undercarriage
 Max. reach
 * Limited by hydr. capacity

The lift capacities on the stick end without attachment are stated in lb x 1,000 and are valid on a firm, level supporting surface with blocked oscillating axle. These capacities can be slewed through 360° with the undercarriage in the transverse position. Capacities in the longitudinal position of the undercarriage (+/- 15°) are specified over the steering axle with the stabilizers raised and over the rigid axle with the stabilizers down. Indicated loads based on the ISO 10567 standard and do not exceed 75% of tipping or 87% of hydraulic capacity. The lift capacity values indicated are attained at the corresponding operating temperature. This operating temperature is ensured by continuous movement of the boom. Weights of fitted working tools (grabs, load hooks, etc.) and load accommodation equipment are to be deducted from the lift capacity values. The lift capacity of the unit is limited by its stability, the lifting capability of the hydraulic elements, or the maximum permissible lifting capacity of the load hook.

LH 40 C – Attachment GA14

Industry – Kinematic 2A

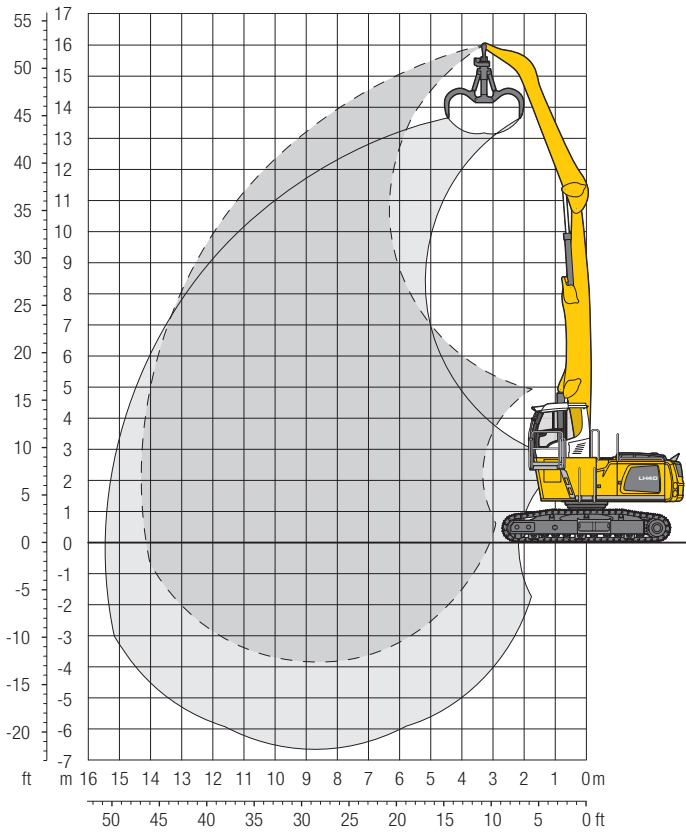

Operating Weight and Ground Pressure

The operating weight includes the basic machine with rigid cab elevation, straight boom 28'3", angled stick 19'8" and grab model GM 70C/ 1.05 yd³ semi-closed tines.

Weight	88,400 lb
Pad width	30"
Ground pressure	on request

Dimensions

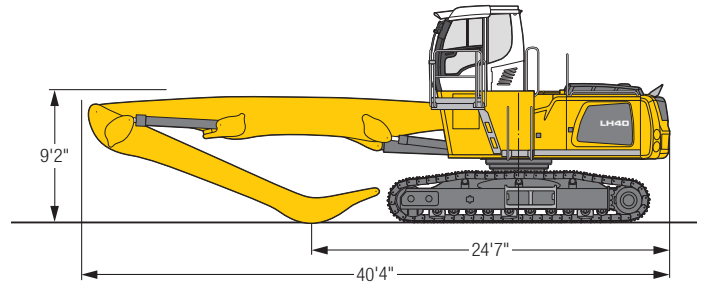

ft	Undercarriage	15 ft		20 ft		25 ft		30 ft		35 ft		40 ft		45 ft		50 ft		ft in			
		EW	EW	EW	EW	EW	EW	EW	EW	EW	EW	EW	EW	EW	EW	EW	EW	EW	EW	EW	
55	EW																				
50	EW	21,2*	21,2*																17,6*	17,6*	18' 4"
45	EW			20,8*	20,8*	17,0*	17,0*												13,9*	13,9*	27' 4"
40	EW					18,0*	18,0*	16,0*	16,0*										12,3*	12,3*	33' 2"
35	EW					17,8*	17,8*	15,7*	15,7*	14,2*	14,2*								11,4*	11,4*	37' 7"
30	EW					17,9*	17,9*	15,7*	15,7*	14,1*	14,1*	12,6	12,7*						10,9*	10,9*	40' 11"
25	EW			21,7*	21,7*	18,3*	18,3*	16,0*	16,0*	14,2*	14,2*	12,6	12,7*						10,7*	10,7*	43' 4"
20	EW	27,2*	27,2*	22,9*	22,9*	19,0*	19,0*	16,4*	16,4*	14,4*	14,4*	12,4	12,7*	10,1	10,8*				10,1	10,6*	45' 1"
15	EW	32,2*	32,2*	24,5*	24,5*	19,9*	19,9*	16,8*	16,8*	14,6*	14,6*	12,2	12,8*	10,0	11,0*				9,6	10,5*	46' 2"
10	EW	35,2*	35,2*	26,0*	26,0*	20,7*	20,7*	17,2*	17,2*	14,5	14,7*	11,9	12,7*	9,9	10,8*				9,3	9,9*	46' 10"
5	EW	13,6*	13,6*	26,7*	26,7*	21,1*	21,1*	17,4*	17,4*	14,1	14,7*	11,6	12,5*	9,8	10,3*				9,2*	9,2*	46' 11"
0	EW	11,4*	11,4*	26,2*	26,2*	20,8*	20,8*	16,9	17,1*	13,7	14,2*	11,4	11,9*	9,3*	9,3*				8,3*	8,3*	46' 5"
-5	EW	12,9*	12,9*	24,0*	24,0*	19,5*	19,5*	16,0*	16,0*	13,2*	13,2*	10,7*	10,7*						8,2*	8,2*	44' 1"
-10	EW			20,1*	20,1*	16,9*	16,9*	14,0*	14,0*	11,4*	11,4*								9,5*	9,5*	38' 5"
-15	EW																				

Height Can be slewed through 360° In longitudinal position of undercarriage Max. reach * Limited by hydr. capacity

The lift capacities on the stick end without attachment are stated in lb x 1,000 and can be slewed through 360° on a firm, level supporting surface. Capacities are valid for 30" wide triple grouser pads (resp. flat pads). Indicated loads based on the ISO 10567 standard and do not exceed 75% of tipping or 87% of hydraulic capacity. The lift capacity values indicated are attained at the corresponding operating temperature. This operating temperature is ensured by continuous movement of the boom. Weights of fitted working tools (grabs, load hooks, etc.) and load accommodation equipment are to be deducted from the lift capacity values. The lift capacity of the unit is limited by its stability, the lifting capability of the hydraulic elements, or the maximum permissible lifting capacity of the load hook.

LH 40 C – Attachment GA16

Industry – Kinematic 2A

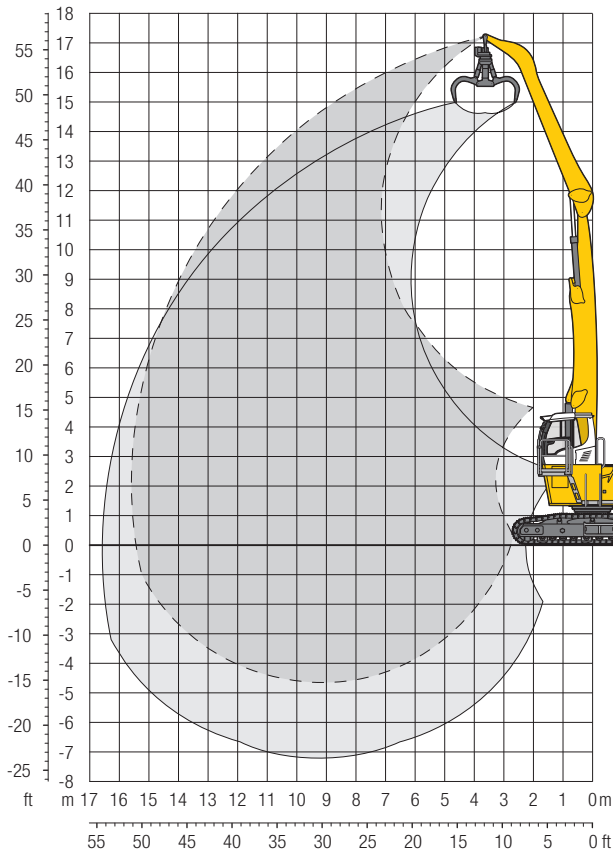

Operating Weight and Ground Pressure

The operating weight includes the basic machine with rigid cab elevation, straight boom 29'10", angled stick 22'4" and grab model GM 65/0.78 yd³ semi-closed tines.

Weight	88,400 lb
Pad width	30"
Ground pressure	on request

Dimensions

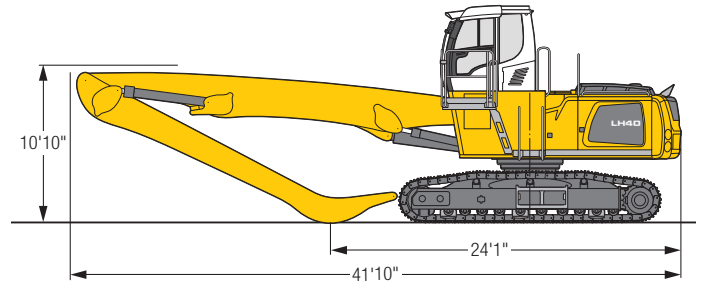

ft	Undercarriage	15 ft		20 ft		25 ft		30 ft		35 ft		40 ft		45 ft		50 ft		ft in		
		EW	EW	EW	EW	EW	EW	EW	EW	EW	EW	EW	EW	EW	EW	EW	EW	EW	EW	EW
55	EW	19,0*	19,0*															17,1*	17,1*	16'11"
50	EW			18,7*	18,7*	15,4*	15,4*											12,8*	12,8*	27' 5"
45	EW					17,3*	17,3*	15,3*	15,3*									11,1*	11,1*	34'
40	EW					16,9*	16,9*	14,9*	14,9*	13,4*	13,4*							10,2*	10,2*	38'11"
35	EW					16,8*	16,8*	14,8*	14,8*	13,2*	13,2*	12,0*	12,0*					9,7*	9,7*	42' 8"
30	EW					17,1*	17,1*	14,9*	14,9*	13,3*	13,3*	12,0*	12,0*	10,3	10,5*			9,3*	9,3*	45' 7"
25	EW			20,8*	20,8*	17,5*	17,5*	15,2*	15,2*	13,4*	13,4*	12,0*	12,0*	10,3	10,8*			9,1	9,2*	47'10"
20	EW			22,0*	22,0*	18,2*	18,2*	15,6*	15,6*	13,6*	13,6*	12,1*	12,1*	10,2	10,8*			8,5	9,1*	49' 5"
15	EW	30,8*	30,8*	23,5*	23,5*	19,0*	19,0*	16,1*	16,1*	13,9*	13,9*	12,1	12,2*	10,0	10,7*	8,3	9,2*	8,2	9,0*	50' 6"
10	EW	33,7*	33,7*	24,9*	24,9*	19,8*	19,8*	16,5*	16,5*	14,1*	14,1*	11,7	12,2*	9,7	10,6*	8,2	8,9*	7,9	8,5*	51'
5	EW	12,7*	12,7*	25,7*	25,7*	20,3*	20,3*	16,7*	16,7*	13,8	14,1*	11,3	12,1*	9,5	10,4*	8,1	8,4*	7,8	7,9*	51'
0	EW	9,7*	9,7*	25,4*	25,4*	20,1*	20,1*	16,5	16,5*	13,3	13,9*	11,0	11,8*	9,3	9,9*	7,5*	7,5*	7,1*	7,1*	50' 7"
-5	EW	10,6*	10,6*	22,6*	22,6*	19,2*	19,2*	15,8*	15,8*	12,9	13,2*	10,8	11,0*	8,9*	8,9*			6,7*	6,7*	49'
-10	EW			20,6*	20,6*	17,2*	17,2*	14,3*	14,3*	11,9*	11,9*	9,7*	9,7*					7,5*	7,5*	44' 7"
-15	EW							11,8*	11,8*									10,3*	10,3*	33' 6"

Height Can be slewed through 360° In longitudinal position of undercarriage Max. reach * Limited by hydr. capacity

The lift capacities on the stick end without attachment are stated in lb x 1,000 and can be slewed through 360° on a firm, level supporting surface. Capacities are valid for 30" wide triple grouser pads (resp. flat pads). Indicated loads based on the ISO 10567 standard and do not exceed 75% of tipping or 87% of hydraulic capacity. The lift capacity values indicated are attained at the corresponding operating temperature. This operating temperature is ensured by continuous movement of the boom. Weights of fitted working tools (grabs, load hooks, etc.) and load accommodation equipment are to be deducted from the lift capacity values. The lift capacity of the unit is limited by its stability, the lifting capability of the hydraulic elements, or the maximum permissible lifting capacity of the load hook.

Liebherr ERC-System

Efficiency
as standard



ERC System – More performance, less consumption

Lowering the equipment stores energy in the ERC system. This stored energy is then made available to the machine to provide additional engine power. When the equipment is raised the stored energy is released and is reflected in powerful, homogeneous operating cycles. The result is a clear saving on fuel – and, at the same time, even greater performance.

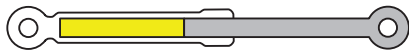

1. Attachment fitting raised /
Energy released

B



2. Lower attachment fitting / Store energy
4. Raise attachment fitting / Release energy



3. Attachment fitting lowered /
Energy stored

A

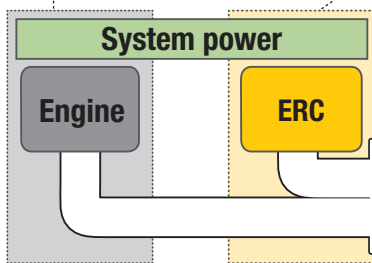
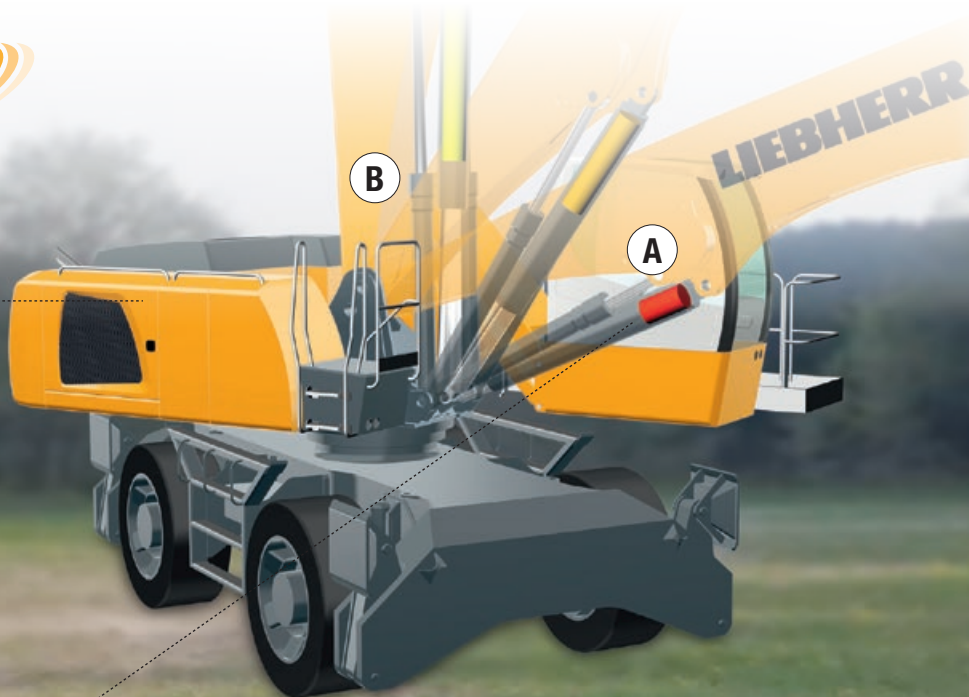

- increased overall power
- fuel savings of up to 30 %
- lower running costs
- reduced pollutant and noise emissions

System power

The energy recovery cylinder is a storage system which is independent of the diesel engine. The system performance of material handling machines fitted with the ERC system is composed of the installed engine power and the energy recovery cylinder. When the equipment is raised, energy from the ERC system is supplied in addition to the power from the diesel engine.

ERC-System

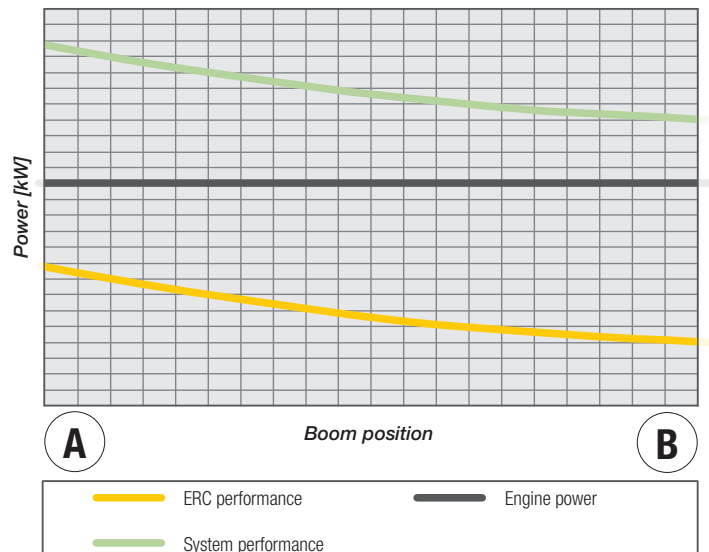

Working Tools

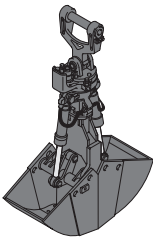

Shells for Loose Material

Shells for loose material with cutting edge (without teeth)

Grab model GM 20C

Width of shells	ft in	3'11"	4'11"	5'9"	6'7"	3'11"	7'5"	8'2"	4'11"	5'9"	6'3"
Capacity	yd ³	1.57	1.96	2.29	2.62	2.75	2.94	3.27	3.27	3.92	4.58
Loose material, specific weight up to	lb/yd ³	2,865	2,865	2,865	2,865	2,530	2,530	2,530	2,530	2,530	2,530
Weight	lb	3,345	3,625	3,855	4,080	3,785	4,315	4,545	4,105	4,370	4,530

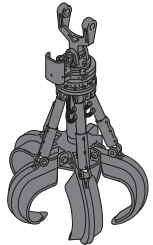

Multi-Tine Grab

open semi-closed closed

Grab model GM 65 (5 tines)

Capacity	yd ³	0.52	0.78	0.52	0.78	0.52	0.78
Weight	lb	2,315	2,555	2,625	2,890	2,975	3,340

Grab model GM 69 (4 tines)

Capacity	yd ³	1.05	1.44	1.05	1.44	1.05	1.44
Weight	lb	3,060	3,165	3,480	3,735	4,290	4,630

Grab model GM 70C (5 tines)

Capacity	yd ³	1.05	1.44	1.05	1.44	1.05	1.44
Weight	lb	3,495	3,630	3,975	4,280	4,525	4,575

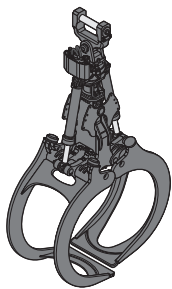

Wood Grab

Grab model GM 20B round-shaped (complete overlapping, vertical cylinders)

Size	yd ²	1.20	1.55	1.79	2.03	2.27
Cutting width	ft in	2'8"	2'8"	2'8"	2'8"	2'8"
Height of grab, closed	ft in	8'5"	7'9"	8'1"	8'4"	9'4"
Weight	lb	3,460	3,525	3,570	3,640	3,935

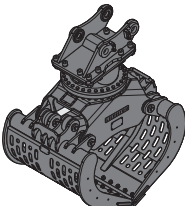

Sorting Grab

ribbed perforated ribbed perforated ribbed perforated

Grab model SG 30B

Width of shells	ft in	3'3"	3'3"	3'11"	3'11"	4'7"	4'7"
Capacity	yd ³	0.98	1.11	1.18	1.31	1.37	1.50
Max. closing force	lbf	17,985	17,985	17,985	17,985	17,985	17,985
Weight incl. adapter plate	lb	4,140	3,935	4,350	4,065	4,550	4,195

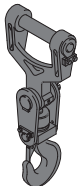

Load Hook with Suspension

Max. load	lb	27,560
Height with suspension	ft in	3'1"
Weight	lb	300

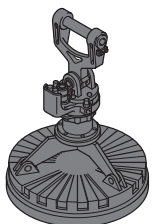



Magnet Devices / Lifting Magnets

Generator	kW	13/17	13/17
Electromagnets with suspension			
Power	kW	8.8	10
Diameter of magnet	ft in	4'1"	4'5"
Weight	lb	2,890	3,750

Equipment

 Undercarriage	40 M	50 M	40 C
Axles with increased traction (reduced speed)		+	
Trailer coupling	+		
Track pads, variants			+
Individual control outriggers	+	+	
Shuttle axle lock, automatic	•	•	
Outrigger monitoring system	+	+	
Tires, variants	+	+	
Protection for piston rods, outriggers	+	+	
Undercarriage, variants			+
Tool equipment, extended	•	•	
Two lockable storage boxes	•	•	

 Uppercarriage	40 M	50 M	40 C
Uppercarriage right side light, 1 piece, LED	+	+	+
Uppercarriage rear light, 2 pieces, LED	+	+	+
Refuelling system with filling pump	+	+	+
Railing on uppercarriage	+	+	+
Generator	+	+	+
Main battery switch for electrical system	•	•	•
Warning beacon on uppercarriage, LED	+	+	+
Protection for headlights	+	+	+
Protection for rear lights	+	+	+
Tool equipment, extended			+

 Hydraulic System	40 M	50 M	40 C
Electronic pump regulation	•	•	•
Liebherr hydraulic oil from -4 °F to +104 °F	•	•	•
Liebherr hydraulic oil, biologically degradable	+	+	+
Magnetic rod in hydraulic tank	•	•	•
Bypass filter	+	+	+
Preheating hydraulic oil	+	+	+

 Engine	40 M	50 M	40 C
Fuel anti-theft device	+	+	+
Air pre-filter with dust discharge	+	+	+
Preheating fuel	+	+	+
Preheating coolant	+	+	+
Preheating engine oil	+	+	+

 Cooling System	40 M	50 M	40 C
Reversible fan drive, fully automatic	+	+	+
Protective grid in front of cooler intake	•	•	•

 Operator's Cab	40 M	50 M	40 C
Cab lights rear, halogen	+	+	+
Cab lights rear, LED	+	+	+
Cab lights front, halogen	+	+	+
Cab lights front, halogen (under rain cover)	•	•	•
Cab lights front, LED	+	+	+
Cab lights front, LED (under rain cover)	+	+	+
Armrest adjustable	•	•	•
Driver profile, personalized (max. 5 drivers)	+	+	+
Operator's seat Comfort	•	•	•
Operator's seat Premium	+	+	+
Driving alarm			
(acoustic signal is emitted during travel, can be switched ON/OFF)	+	+	+
Fire extinguisher	+	+	+
Horn, button on left joystick	•	•	•
Joystick steering (max. 7.5 mph)	•	•	
Joystick and wheel steering (slim version)	+	+	
Cab elevation, hydraulic (LHC)	•	•	•
Cab elevation, rigid (LFC)	+	+	+
Automatic air conditioning	•	•	•
Wheel steering (slim version)	+	+	
LiDAT Plus (extended Liebherr data transfer system) *	•	•	•
Automatic engine shut-down (time adjustable)	+	+	+
Bullet proof glass	+	+	+
Positioning swing brake	+	+	+
Proportional control	•	•	•
Radio Comfort, control via display with handsfree set	+	+	+
Preparation for radio installation	•	•	•
Back-up alarm			
(acoustic signal is emitted traveling backward, can not be switched off)	+	+	
Warning beacon on cab, LED	+	+	+
Windscreen wiper, roof	+	+	+
Top guard	+	+	+
Front guard, adjustable	+	+	+
Flashing light (xenon)	+	+	+

 Attachment	40 M	50 M	40 C
Boom lights, 2 pieces, halogen	•	•	•
Boom lights, 2 pieces, LED	+	+	+
Stick lights, 2 pieces, halogen	•	•	•
Stick lights, 2 pieces, LED	+	+	+
Boom shutoff (retract/extend), electronically	+	+	+
AutoLift	+	+	+
ERC system	•	•	•
Electronic lift limitation	+	+	+
Boom cylinder cushioning	+	+	+
Industrial stick with quick coupling	+	+	+
Stick camera (with separate monitor), bottom side, with protection	+	+	+
Load torque limitation	+	+	+
Liebherr multi coupling system	+	+	+
Liebherr quick coupler, hydraulic	+		+
Pipe fracture safety valves hoist cylinders	•	•	•
Pipe fracture safety valve stick cylinder	•	•	•
Quick coupling system LIKUFIX	+	+	+
Quick coupling system MH40	+	+	+
Protection for piston rod, energy recovering cylinder	+	+	+
Protection for piston rods, hoist cylinder	+	+	+
Stick shutoff (retract), electronically	•	•	•
Stick shutoff (retract/extend), electronically	+	+	+
Retract stick without pressure	•	•	•
Overload warning device	+	+	+

 Complete Machine	40 M	50 M	40 C
Lubrication			
Lubrication undercarriage, manually – decentralized (grease points)	•	•	
Central lubrication system for uppercarriage and attachment, automatically	•	•	•
Central lubrication system for undercarriage, automatically	+	+	
Special coating, variants	+	+	+
Monitoring			
Rear view monitoring with camera	•	•	•
Side view monitoring with camera	+	+	+

• = Standard, + = Option

* = optionally extendable after one year

Options and/or special attachments, supplied by vendors other than Liebherr, are only to be installed with the knowledge and approval of Liebherr in order to retain warranty.

The Liebherr Group of Companies

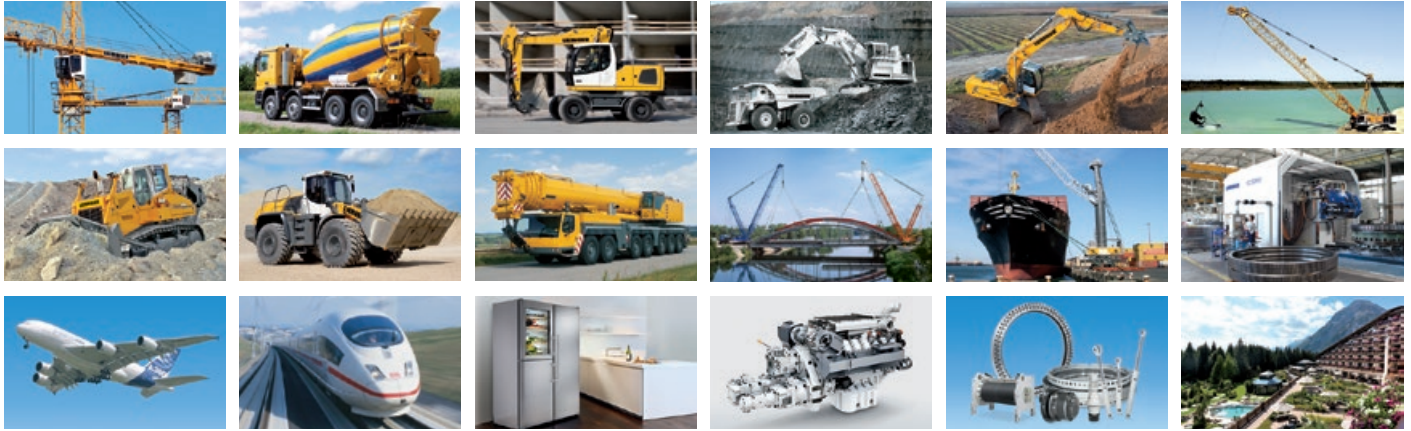

Wide Product Range

The Liebherr Group is one of the largest construction equipment manufacturers in the world. Liebherr's high-value products and services enjoy a high reputation in many other fields. The wide range includes domestic appliances, aerospace and transportation systems, machine tools and maritime cranes.

Exceptional Customer Benefit

Every product line provides a complete range of models in many different versions. With both their technical excellence and acknowledged quality, Liebherr products offer a maximum of customer benefits in practical application.

State-of-the-art Technology

To provide consistent, top quality products, Liebherr attaches great importance to each product area, its components and core technologies. Important modules and components are developed and manufactured in-house, for instance the entire drive and control technology for construction equipment and mining trucks.

Worldwide and Independent

Hans Liebherr founded the Liebherr family company in 1949. Since that time, the enterprise has steadily grown to a group of more than 130 companies with over 41,000 employees located on all continents. The corporate headquarters of the Group is Liebherr-International AG in Bulle, Switzerland. The Liebherr family is the sole owner of the company.

www.liebherr.us