

# Crawler excavator

**R 936**  
Litronic®

Motor:  
**228 HP / 170 kW** SAE J1349  
**231 HP / 170 kW** ISO 9249  
**Stage Tier 4f**

Operating Weight:  
**68,230 – 85,210 lb**

Bucket Capacity:  
**1.30 – 2.80 yd<sup>3</sup>**



# LIEBHERR

## R 936 Litronic

### Motor:

228 HP / 170 kW (SAE J1349)

231 HP / 170 kW (ISO 9249)

Stage Tier 4f

### Operating Weight:

68,230 – 85,210 lb

### Bucket Capacity:

1.30 – 2.80 yd<sup>3</sup>

## Performance

Performance, precision  
and responsiveness



## Efficiency

High level of productivity for a lower overall operating cost

## Reliability

Result of ongoing improvements

## Comfort

Spacious, ergonomic and with high-visibility

## Maintainability

Simplified daily checks, longer maintenance intervals



# Performance



**Performance, precision  
and responsiveness**

### Advanced techniques heighten performance

In its design offices, Liebherr combines the technological know-how of each area to create consistent and optimised integrated systems. Liebherr's electronics, positive control hydraulics, and even the engines are designed from the start to be interconnected and generate optimum operating power with fast and fluid movements.

### Positive Control hydraulic system

Two working pumps for maximum excavation power and travel power, and a pump serving the rotation circuit provides power to the components involved. Thanks to the positive control system, the combined movements are optimised for each different work operation, whether this be levelling, extraction/loading or lifting, with or without travel.

### Particularly fast work cycles

The work cycles of the R 936 are very fast thanks to the large sized transmission components. For example, the uppercarriage's swing drive can quickly reach its maximum speed with a high swing torque.

### Operating pressure

Maximum digging and break-out forces can be reached thanks to the level of hydraulic pressure, without applying temporary overpressure. Maximum forces are therefore guaranteed continuously during the whole working phase to achieve a high level of production.

### Liebherr Engine

- New Stage Tier4f engine with SCR exhaust gas after-treatment system
- Designed specifically for construction applications
- Liebherr common rail injection system for optimised output
- Automatic fuel-saving idling system
- Fixed geometry turbo charger

### Undercarriage

- Robust design for greater resistance and a better distribution of forces
- Easy and safe transport thanks to integrated securing hooks
- Three different types of undercarriages, one with variable gauge, adapted to different operating configurations and transport conditions

### Wide range of operational possibilities

- Large number of equipment variants
- Versatile selection of undercarriage variants
- Attachments for all applications: short reach, standard, luffing jib attachments



# Efficiency



**High level of productivity for  
a lower overall operating cost**

### Less fuel

The new 4-cylinder Liebherr engine, pursuant to the Stage Tier4f emission standards, comprises a diesel exhaust fluid injection device (SCR) for the after-treatment of exhaust gases, with no need for a particle filter, diesel oxidation catalyst or EGR. Associated with the latest technological advances in hydraulics, this engine consumes less fuel, both in terms of hours of operation and in terms of tons of material moved.

### Increased productivity

Clearly enhanced performance thanks to new equipment and lower consumption, all in a comfortable and ergonomic work environment, lead to remarkable gains in productivity in all operating configurations.

### Simplified and lower-cost maintenance

Non-slip platforms and ergonomic handles allow fast and easy access to all maintenance points not accessible from the ground. The absence of a particle filter reduces maintenance time, the cost of spare parts and filter regeneration operations.

### Electronic power control

This control system allows the engine power to be effectively and optimally converted, from an energetic point of view, into hydraulic power. This is as a result of greater forces, a faster working speed and a lower fuel consumption.



### Liebherr Lubricants

- Liebherr lubricants are specially developed for application in Liebherr earth moving and material handling machines and guarantee a long working life whilst simultaneously delivering the highest possible performance
- Being designed especially for your Liebherr machines, Liebherr lubricants contribute significantly to lowering your operating and maintenance costs.

### Liebherr tools

- Wide range of tools suitable for every type of application
- Tools designed for maximum productivity and durability
- Shape of buckets designed to assist the filling and stability of bulky materials during the transport stages
- Hydraulic quick coupler system

### Modular quick-change system made by Liebherr

- Likufix – connects all hydraulically mounted tools without having to leave the operator's cab, maximum productivity due to tool change being performed in a matter of seconds
- The suitable digging tool for every application. Your machine is a multifunctional tool carrier and will pay for itself very quickly indeed
- Mechanic and hydraulic Liebherr quick-change adapter

# Reliability



**Result of ongoing  
improvements**



### Quality in the minutest details

Robust and large-sized components, optimal fitting of electrical and hydraulic lines, or an exemplary level of finishing are just some of the many criteria that ensure a maximum quality of manufacture and operability.

### A top-of-the-range anti-corrosion protection

A pre-assembly painting process guarantees that all painted parts are fully coated. The same quality can thus be guaranteed for all special colours specifically requested by the most exacting customers. This process is also compatible with additional protection treatments for machines operating in an aggressive saline environment.

### Perfect match

The individual components of the power train, such as the diesel engine, gears, swing drive, working pumps and hydraulic cylinders are designed and manufactured by Liebherr. This means that they are all compatible with each other in a global system, guaranteeing greater reliability and a longer service life.

### Automatic control of functionality

The operator can entirely focus on his job, because the integrated on-board electronic continuously performs a comparison with pre-determined target data. Eventual deviations from the target parameters are shown on the display.

### SCR system with diesel exhaust fluid (AdBlue®)

- Diesel exhaust fluid level indicator on the display
- Liebherr design
- Complies with Stage Tier4f standard
- No need for particle filters (DPF), diesel oxidation catalyst and EGR
- Simple system for enhanced reliability and less maintenance

### Key technologies – Made by Liebherr

- Perfect matching of the components to construction machine operations
- Engine, hydraulic pumps, transfer gears, travel drives, slewing drives, slewing rings, and electronic components – all from the same source
- Main steel components, such as undercarriage, equipment modules, and slewing superstructure, all designed by Liebherr

### Spare parts service

- Any spare parts required are available within 24 hours – worldwide. And that means high operational readiness of the machines, wherever, whenever
- Over 80,000 spare parts in stock at all times



# Comfort



**Spacious, ergonomic  
and with high-visibility**

### A first class work space

In this cab, the operator has a pneumatic seat with horizontal and vertical damping, lots of space and a very comfortable and silent work environment. Depending on the operator's needs, the Liebherr Premium seat can also be chosen as an option. This seat offers maximum seating comfort thanks to its pneumatic lumbar support, its electronic weight-actuated height adjuster and its air-conditioning with activated charcoal and built-in fan. It is especially designed to meet the most exacting requirements of operators in terms of comfort, in all working situations.

### Low noise level and vibrations

To diminish fatigue at work and increase productivity, the acoustic power inside the operator's cab is minimized. The cab is mounted on viscoelastic rivets to fully absorb the excavator's vibrations. The rubber flanges also support the pipes and actively participate in reducing external noise.

### Uncompromised visibility

The very large glazed surface area and minimal area of uprights guarantee optimal visibility from the operator's platform, as well as a wide safety exit from the rear window for the operator's safety and peace of mind.

### Ergonomic proportional manipulators

The proportional manipulators are very finely tuned controls for the sensitive, accurate and fluid operation of hydraulic tools. This type of control is ideal for an R 936 used in a variety of applications.



#### Touch-screen display

- 7-inch touch-screen with colour display
- Wide range of adjustment, check, and monitoring possibilities
- Tough, reliable design (sealing tightness class IP 65)
- Video capacity with high resolution, reproduces the image from the rear area monitor camera in best possible quality

#### Heightened visibility

- Rear camera integrated in the counterweight as standard (camera for side area monitoring optional), for rear visibility and heightened operating safety
- Optimized design of the whole uppercarriage providing the operator with an improved field of vision
- Retractable laminated glass roof panel
- Secure emergency exit through the rear window

#### New options

- Engine compartment lighting
- LED headlights with adjustable intensity
- 360° camera
- Follow me home (headlight cutoff delay)
- Windscreen wiper on bottom part from front window
- Preparation for automatic pedestrian detection system
- Preparation for machine guidance system
- Preparation for weighing system

# Maintainability



**Simplified daily checks,  
longer maintenance intervals**

### Simplified daily checks

The daily checks were taken into account from the start of the design, to make them simpler, more accessible and shorter. The engine oil or diesel exhaust fluid levels, for example, can be checked via the display in the operator's cab. The automatic centralised lubrication system can save precious intervention time, while guaranteeing that the excavator is in optimum operating condition.

### Longer service intervals

The frequency of the service intervals is optimised to guarantee that each part is operating optimally and that the maintenance operations are only performed as necessary. Whether it is the interval for changing the hydraulic oil, which can be up to 8,000 hours, or the interval for changing the engine oil, which can reach 2,000 hours, everything has been taken into account to reduce the frequency of interventions and thus limit the machine's downtime and reduce costs.

### A maintenance-free exhaust gas treatment

Thanks to its unique Liebherr design, the exhaust gas treatment is carried out in compliance with the Stage Tier4f standards, without fitting a particle filter, diesel oxidation catalyst or EGR. This results in a maximum reliability in an output with no loss of productivity linked to the regeneration of these filters and, of course, there is no maintenance time or cost for spare parts associated with this technology.

### Expert advice and service provisions

Liebherr offers an expert advice service. Qualified personnel will help you make the appropriate decisions to meet your needs: sales arguments based on the terrain, service agreements, advantageous repair alternatives, original parts management, and remote data transfer for fleet management.

#### LiDAT data transfer system

- Complete fleet management, all from one source
- Optimized economical performance of the machine park thanks to detailed view of the distribution of operating states and times
- Reports on capacity commitment and the use of the machine park can be called up daily via the Web portal
- Precise location of the machine
- Regional delimitation and fixed downtimes increase safety and reliability

#### Hydraulic reservoir stop valve

- Easy and quick interruption of the oil circuit between hydraulic reservoir and hydraulic system
- No drainage of fluid necessary for service or repair work on the hydraulic system

#### Central lubrication system

- The fully-automatic central lubrication system, fitted as standard, allows for rapid maintenance: It saves time-consuming individual lubricating and downtime
- All the lubrication points on the superstructure of the vehicle and the attachment hydraulics are supplied, with the exception of the connecting plate
- Engine oil level visible on display



# Long live progress with the R 936

## Equipment

- Cast steel elements
- Greater resistance to stresses
- Optimal lifetime
- New equipment strengthened with more force

## Tools

- Z-type Liebherr teeth for fast replacement
- Wide range of work tools
- QC48 and QC66 Liebherr quick-couplers both available

## Undercarriage

- Special heat treatment for low wear and tear of drive sprockets
- A wide range of undercarriages suited to each application
- Robust construction





#### **Operator's cab**

- Comfortable and ergonomic
- 7" high resolution color touchscreen for heightened readability
- Rear window with improved visibility

#### **Automatic centralized lubrication - standard**

- Reduced maintenance time
- Longer service life thanks to better lubrication

#### **Visibility**

- Rear camera integrated in the counterweight
- Optimized design of the whole uppercarriage providing the operator with a better field of vision
- Large glazed surface area with secure emergency exit through the rear window

# Technical Data



## Engine

<b>Rating</b>	
per SAE J1349	228 HP (170 kW) at 1,800 rpm
per ISO 9249	231 HP (170 kW) at 1,800 rpm
<b>Torque</b>	922 lbf ft at 1,100 rpm
<b>Model</b>	Liebherr D934 A7
<b>Type</b>	4 cylinder in-line
Bore/Stroke	4.8/5.9 in
Displacement	427 in <sup>3</sup>
<b>Engine operation</b>	4-stroke diesel
	Common-Rail, monoturbo
<b>Exhaust gas treatment</b>	SCR with urea injection
	emission standard Tier 4 final/Stage IV
<b>Cooling system</b>	water-cooled and integrated motor oil cooler, after-cooled and fuel cooled
<b>Air cleaner</b>	dry-type air cleaner with pre-cleaner, primary and safety elements
<b>Fuel tank</b>	148 gal
<b>Urea tank</b>	17 gal
<b>Electrical system</b>	
Voltage	24 V
Batteries	2 x 180 Ah/12 V
Starter	24 V/7.8 kW
Alternator	three-phase current 28 V/100 A
Engine idling	sensor controlled
<b>Motor management</b>	connection to the integrated excavator system controlling via CAN-BUS to the economical utilisation of the service that is available



## Hydraulic Controls

The controlling is conducted via the integrated excavator system technology, input and output modules, communicated via the CAN-BUS with the electronic central unit

<b>Power distribution</b>	via control valve with integrated safety valves
<b>Servo circuit</b>	
Attachment and swing	proportional via joystick levers
Travel	– with proportionally functioning foot pedals and adjusted with a plugable lever – speed pre-selection
<b>Additional functions</b>	proportional regulation via foot pedals or rocker



## Hydraulic System

<b>Hydraulic system</b>	Positive Control dual circuit hydraulic system for independent and need-based quantity allotment via the hydraulic pumps; sensor-guided. Features high system dynamics and sensibility provided by integrated system controlling.
	Independent circuit for rotation.
<b>Hydraulic pump</b>	
for attachment and travel drive	Liebherr, variable displacement, swashplate double pump
Max. flow	2 x 63 gpm
Max. pressure	5,511 psi
for swing drive	reversible, variable flow, swashplate pump, closed-loop circuit
Max. flow	46 gpm
Max. pressure	5,800 psi
<b>Pump management</b>	electronic pump management via the integrated system controlling (CAN-BUS) synchronous to the control block
<b>Hydraulic tank</b>	71 gal
<b>Hydraulic system</b>	max. 126 gal
<b>Hydraulic oil filter</b>	1 full flow filter (10 µm) in return line with integrated fine filter area (5 µm)
<b>Cooling system</b>	compact cooler, consisting of a water cooler, sandwiched with hydraulic oil cooler, gearbox oil cooler, fuel cooler and after-cooler cores and hydrostatically driven fan
<b>MODE selection</b>	adjustment of engine and hydraulic performance via a mode pre-selector to match application, e.g. for especially economical and environmentally friendly operation or for maximum digging performance and heavy-duty jobs
<b>RPM adjustment</b>	stepless adjustment of engine output via RPM at each selected mode
<b>Tool Control</b>	10 preadjustable pump flows and pressures for add-on tools
<b>Drive</b>	Liebherr swashplate motor
<b>Transmission</b>	Liebherr compact planetary reduction gear
<b>Swing ring</b>	Liebherr, sealed race ball bearing swing ring, internal teeth
<b>Swing speed</b>	0 – 9.3 rpm stepless
<b>Swing torque</b>	69,330 lbf ft
<b>Holding brake</b>	wet multi-disc (spring applied, pressure released)



## Swing Drive





## Operator's Cab

<b>Cab</b>	ROPS safety cab structure with individual windscreens or featuring a slide-in subpart under the ceiling, work headlights integrated in the ceiling, a door with a side window (can be opened on both sides), large stowing and depositing possibilities, shock-absorbing suspension, sounddamping insulating, tinted laminated safety glass, separate window shades for the sunroof window and windscreen, 12 V plug, storage bins, lunchbox, cup holder
<b>Operator's seat</b>	Comfort seat, airsprung with automatic weight adjustment, vertical and horizontal seat damping including consoles and joysticks. Seat and armrests adjustable separately and in combination, seat heating as standard
<b>Control system</b>	arm consoles, swinging with the seat
<b>Operation and displays</b>	large high-resolution color display with selfexplanatory operation via touchscreen, video, versatile adjusting, control and monitoring facilities, e.g. climate control, implement and tool parameters
<b>Air-conditioning</b>	standard automatic air-conditioning, ambient air function, fast de-icing and demisting at the press of a button, air vents can be operated via a menu. Ambient air and fresh air filters can be easily replaced and are accessible from the outside. Heating-cooling unit, designed for extreme outside temperatures, sensors for solar radiation, inside and outside temperatures



## Undercarriage

<b>Versions</b>	NLC gauge 7'10" LC gauge 8'6" LC-V gauge 7'10"/8'2" (transport position) gauge 9'9'6" (work position)
<b>Drive</b>	Liebherr swashplate motors with integrated brake valves on both sides
<b>Transmission</b>	Liebherr planetary reduction gears
<b>Travel speed</b>	low range – 2.0 mph high range – 3.2 mph
<b>Net drawbar pull on crawler</b>	NLC/LC: 58,675 lbf LC-V: 66,094 lbf
<b>Track components</b>	D7, maintenance-free
<b>Track rollers/Carrier rollers</b>	9/2
<b>Tracks</b>	sealed and greased
<b>Track pads</b>	triple grouser
<b>Holding brake</b>	wet multi-discs (spring applied, pressure released)
<b>Brake valves</b>	integrated into travel motor
<b>Lashing eyes</b>	integrated



## Attachment

<b>Type</b>	combination of resistant steel plates and cast steels components
<b>Hydraulic cylinders</b>	Liebherr cylinders with special seal-system, shock protection
<b>Bearings</b>	sealed, low maintenance
<b>Lubrication</b>	automatic central lubrication system (except link and tilt geometry)
<b>Hydraulic connections</b>	pipes and hoses equipped with SAE splitflange connections
<b>Bucket</b>	standard equipped with Liebherr tooth system

# Dimensions

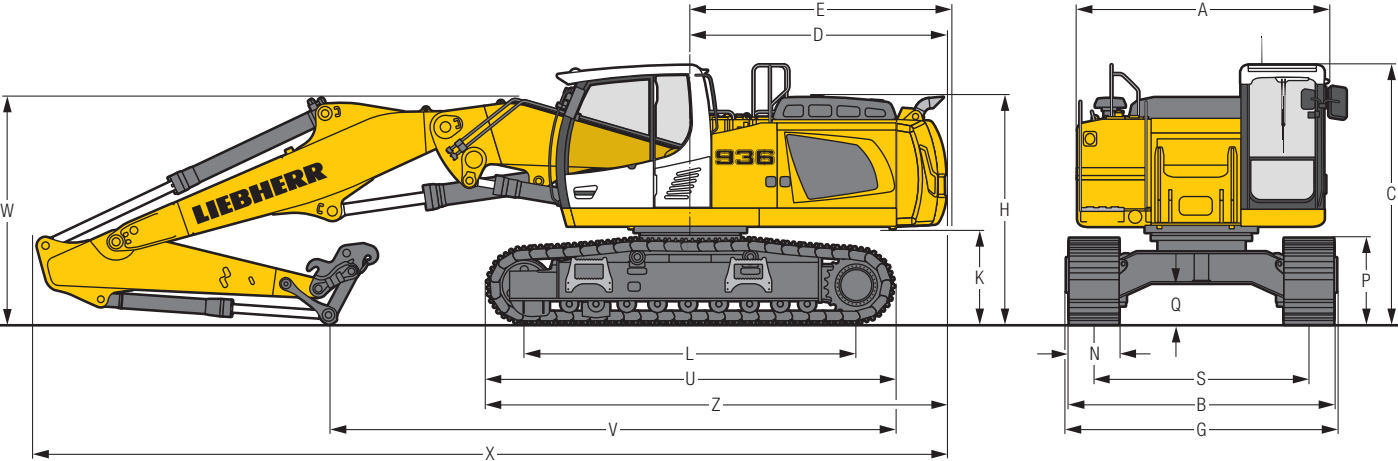
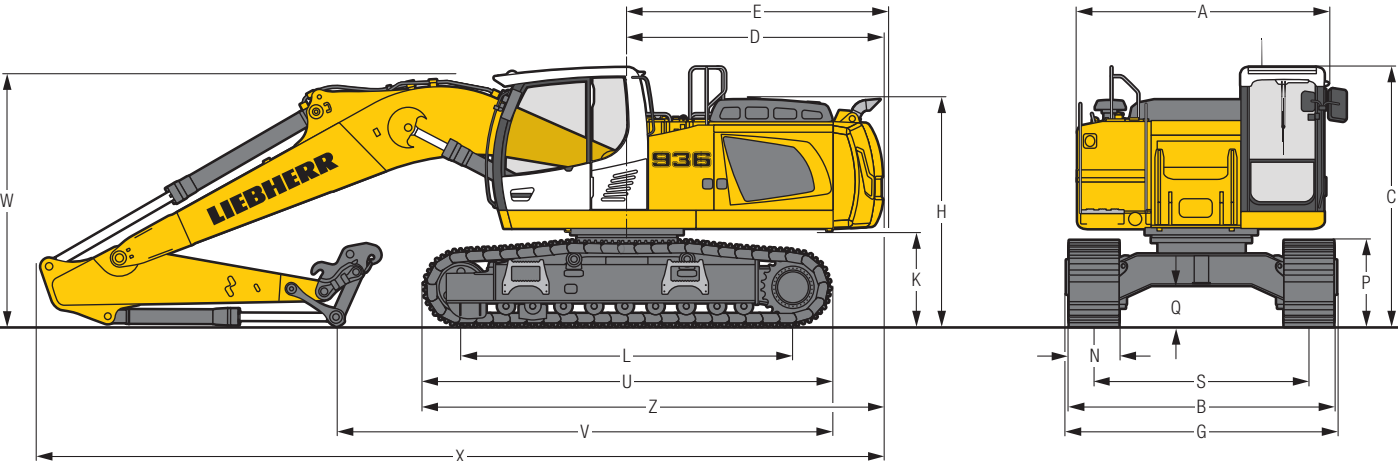

	NLC				ft in	LC	ft in	LC-V	ft in
A					9'10"		9'10"		9'10"
C					10' 3"		10' 3"		10' 8"
D					10' 1"		10' 1"		10' 1"
E					10' 4"		10' 4"		10' 4"
H					9' 1"		9' 1"		9' 5"
K					3' 9"		3' 9"		4' 2"
L					13' 1"		13' 1"		13' 6"
P					3' 5"		3' 5"		3' 8"
Q					1' 7"		1' 7"		2' 3"
S					7'10"		8' 6"		7'10" – 8'2" / 9' – 9' 6"
U					16' 2"		16' 2"		16' 5"
N	20"	24"	30"	35"		20"	24"	30"	35"
B	9' 9"	9'10"	10' 4"	10'10"		10' 5"	10' 6"	10'11"	11' 5"
G	9'10"	9'10"	10'11"	10'11"		10' 6"	10' 6"	11' 7"	11' 7"
Z					18' 2"		18' 2"		18' 4"

\* work position

\*\* width with removable steps

NLC-Undercarriage				
	Stick length	Mono boom	Straight mono boom	Two-piece boom
	ft in	ft in	ft in	ft in
V	8' 2"	19' 8"	21'10"	22' 4"
	9' 2"	18' 8"	21' 2"	21' 2"
	10' 2"	17'11"	20' 6"	20'
	12'10"	15' 7"	18'10"	16'11"
W	8' 2"	10'	9' 8"	9' 4"
	9' 2"	10'	9'10"	9' 4"
	10' 2"	10' 2"	10' 2"	9' 6"
	12'10"	10' 6"	11' 4"	9'10"
X	8' 2"	33' 6"	35' 3"	36' 1"
	9' 2"	33' 8"	35' 3"	36' 1"
	10' 2"	33' 8"	35' 5"	35'11"
	12'10"	33'10"	35' 5"	35' 7"

LC-Undercarriage				
	Stick length	Mono boom	Straight mono boom	Two-piece boom
	ft in	ft in	ft in	ft in
V	8' 2"	19' 8"	21'10"	22' 4"
	9' 2"	18' 8"	21' 2"	21' 2"
	10' 2"	17'11"	20' 6"	20'
	12'10"	15' 7"	18'10"	16'11"
W	8' 2"	10'	9' 8"	9' 4"
	9' 2"	10'	9'10"	9' 4"
	10' 2"	10' 2"	10' 2"	9' 6"
	12'10"	10' 6"	11' 4"	9'10"
X	8' 2"	33' 6"	35' 3"	36' 1"
	9' 2"	33' 8"	35' 3"	36' 1"
	10' 2"	33' 8"	35' 5"	35'11"
	12'10"	33'10"	35' 5"	35' 7"

LC-V-Undercarriage				
	Stick length	Mono boom	Straight mono boom	Two-piece boom
	ft in	ft in	ft in	ft in
V	8' 2"	19' 8"	21' 8"	22' 4"
	9' 2"	18' 8"	20'10"	21' 2"
	10' 2"	17' 9"	20' 2"	20'
	12'10"	15' 3"	18' 6"	17' 3"
W	8' 2"	10' 2"	9'10"	9' 6"
	9' 2"	10' 2"	9'10"	9' 6"
	10' 2"	10' 4"	10' 2"	9' 8"
	12'10"	10' 6"	11' 4"	10'
X	8' 2"	33' 6"	35' 3"	36' 1"
	9' 2"	33' 8"	35' 3"	36' 1"
	10' 2"	33' 8"	35' 5"	35'11"
	12'10"	33'10"	35' 5"	35' 7"

# Backhoe Bucket

with Mono Boom 19'10" and Counterweight 11,905 lb

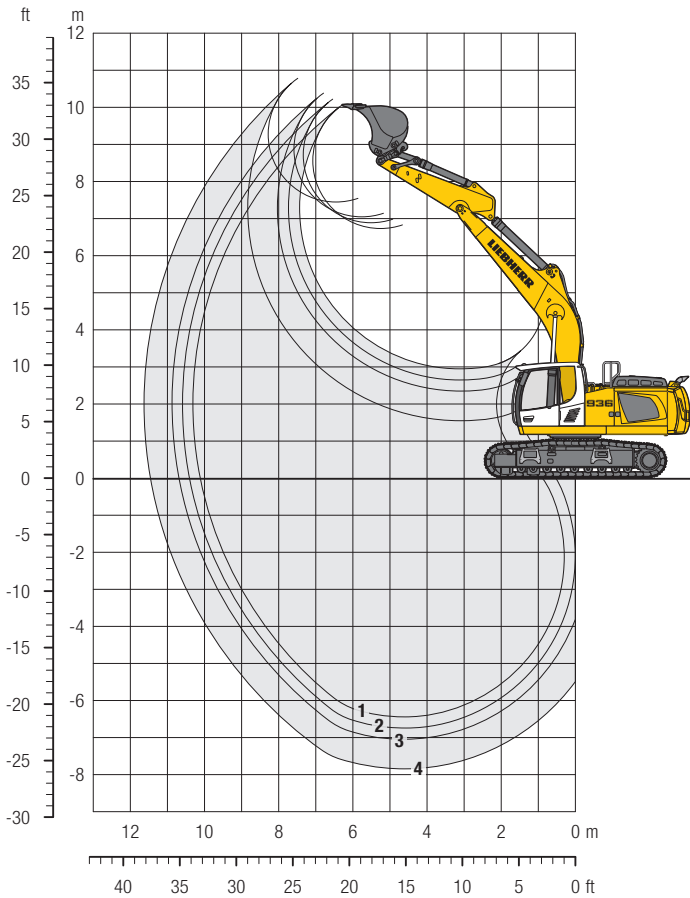

## Digging Envelope

with quick coupler		1	2	3	4
Stick length	ft in	8'2"	9'2"	10' 2"	12'10"
Max. digging depth	ft in	21'2"	22'2"	23' 2"	25' 9"
Max. reach at ground level	ft in	33'2"	34'1"	35' 1"	37' 7"
Max. dumping height	ft in	22'2"	22'8"	23' 2"	24' 5"
Max. teeth height	ft in	33'	33'6"	33'11"	35' 5"

## Digging Forces

with quick coupler		1	2	3	4
Digging force ISO	lbf	36,640	34,170	31,920	27,200
	lb	36,600	34,170	31,970	27,120
Breakout force ISO	lbf	40,240	40,240	40,240	40,240
	lb	40,120	40,120	40,120	40,120
without quick coupler					
Digging force ISO	lbf	38,670	35,970	33,500	28,330
	lb	38,580	35,940	33,510	28,220
Breakout force ISO	lbf	46,540	46,540	46,540	46,540
	lb	46,520	46,520	46,520	46,520

## Operating Weight and Ground Pressure

The operating weight includes the basic machine with counterweight 11,905 lb, mono boom 19'10", stick 8'2", quick coupler SW66 and bucket 1.31 yd<sup>3</sup> (2,115 lb).

Undercarriage		NLC			LC		
Pad width	in	20"	24"	30"	20"	24"	30"
Weight	lb	68,225	69,005	71,100	68,455	69,225	71,320
Ground pressure	psi	10.2	8.7	7.1	10.2	8.7	7.1

Undercarriage		LC-V		
Pad width	in	20"	24"	30"
Weight	lb	76,831	77,823	79,256
Ground pressure	psi	11.2	9.5	7.7

Optional: heavy counterweight

(counterweight 13,890 lb increases the operating weight by 1,985 lb and ground pressure by 0.3 psi) see load tables on page 26

## Buckets Machine stability per ISO 10567\* (75% of tipping capacity)

STD <sup>1)</sup>	Cutting width in	Capacity ISO 7451 yd <sup>3</sup>	Weight <sup>2)</sup> lb	Weight <sup>3)</sup> lb	NLC-Undercarriage								LC-Undercarriage								LC-V-Undercarriage							
					Stick length (ft in)				Stick length (ft in)				Stick length (ft in)				Stick length (ft in)				Stick length (ft in)							
					8'2"	9'2"	10'2"	12'10"	8'2"	9'2"	10'2"	12'10"	8'2"	9'2"	10'2"	12'10"	8'2"	9'2"	10'2"	12'10"	8'2"	9'2"	10'2"	12'10"				
					without quick coupler				with quick coupler				without quick coupler				with quick coupler				without quick coupler				with quick coupler			
	41"	1.31	2,070	2,115	▲	▲	▲	▲	▲	▲	▲	▲	▲	▲	▲	▲	▲	▲	▲	▲	▲	▲	▲	▲				
	49"	1.63	2,360	2,405	▲	▲	▲	▲	▲	▲	▲	▲	▲	▲	▲	▲	▲	▲	▲	▲	▲	▲	▲	▲				
	55"	1.90	2,515	2,555	▲	▲	▲	■	▲	▲	▲	■	▲	▲	▲	■	▲	▲	▲	■	▲	▲	▲	■				
	61"	2.09	2,670	2,710	▲	▲	▲	■	▲	▲	▲	■	▲	▲	▲	■	▲	▲	▲	■	▲	▲	▲	■				
	65"	2.29	2,865	2,910	▲	▲	■	■	▲	■	■	■	▲	▲	■	■	▲	▲	■	■	▲	▲	■	■				
	61"	2.42	2,865	2,890	▲	■	▲	△	■	■	▲	△	▲	▲	■	■	▲	▲	■	■	▲	▲	■	■				
	65"	2.62	3,065	3,110	■	■	■	△	▲	■	■	△	▲	■	▲	△	▲	▲	▲	△	▲	▲	▲	△				
	69"	2.81	3,415	-	▲	■	△	-	-	-	-	-	■	▲	■	△	-	-	-	-	▲	▲	■	△				

\* Indicated loads are based on ISO 10567 max. stick length, lifted 360° on firm

<sup>1)</sup> Standard bucket with teeth Z 50

<sup>2)</sup> Bucket for direct fitting

<sup>3)</sup> Bucket for fitting to quick coupler (SW66, 772 lb)

Other backhoes available on request

Max. material weight ▲ = ≤ 3,371 lb/yd<sup>3</sup>, ■ = ≤ 3,034 lb/yd<sup>3</sup>, ▲ = ≤ 2,781 lb/yd<sup>3</sup>, ■ = ≤ 2,528 lb/yd<sup>3</sup>, △ = ≤ 2,023 lb/yd<sup>3</sup>, - = not authorized

# Lift Capacities

with Mono Boom 19'10" and Counterweight 11,905 lb

## Stick 8'2"

ft	Under-carriage	10 ft		15 ft		20 ft		25 ft		30 ft		ft in
		LC	LC-V	LC	LC-V	LC	LC-V	LC	LC-V	LC	LC-V	
35	NLC LC LC-V											
30	NLC LC LC-V											
25	NLC LC LC-V					16.8*	16.8*			13.1*	13.1*	20' 7"
20	NLC LC LC-V					18.4*	18.4*			13.0*	13.0*	24' 4"
15	NLC LC LC-V	39.7*	39.7*	26.1	26.4*	17.0	21.4*	12.2	19.0*	11.1	12.1*	26' 6"
10	NLC LC LC-V	39.7*	39.7*	26.4*	26.4*	18.5	21.4*	13.2	19.0*	12.0	12.1*	27' 7"
5	NLC LC LC-V	41.4*	41.4*	26.8*	26.8*	21.6*	21.6*	16.3	19.1*	12.1*	12.1*	27' 10"
0	NLC LC LC-V			24.1	32.0*	16.2	23.8*	11.8	19.5	10.2	12.4*	27' 1"
-5	NLC LC LC-V	33.9*	33.9*	22.1	33.7*	14.8	25.6*	11.2	18.8	13.9	14.8*	25' 4"
-10	NLC LC LC-V	37.4*	37.4*	24.4	33.7*	16.3	25.6*	12.2	18.9	12.0	17.4*	22' 4"
-15	NLC LC LC-V	36.7*	36.7*	28.6*	28.6*	20.8	21.6*			17.4*	17.4*	16' 8"
-20	NLC LC LC-V			20.0*	20.0*							

## Stick 9'2"

ft	Under-carriage	10 ft		15 ft		20 ft		25 ft		30 ft		ft in				
		LC	LC-V	LC	LC-V	LC	LC-V	LC	LC-V	LC	LC-V					
35	NLC LC LC-V															
30	NLC LC LC-V															
25	NLC LC LC-V							18.0	18.4*			11.5*	11.5*	21' 10"		
20	NLC LC LC-V							18.4*	18.4*			11.4*	11.4*	25' 4"		
15	NLC LC LC-V	37.4*	37.4*	25.5*	25.5*	20.8*	20.8*	16.3	18.4*	10.5	10.6*	10.6*	10.6*	27' 6"		
10	NLC LC LC-V			24.3	30.8*	16.2	23.1*	11.8	19.4*	9.6	10.8*	10.5	10.8*	28' 6"		
5	NLC LC LC-V			22.7	34.9*	15.4	25.4*	11.4	19.0	9.4	11.5*	10.9	10.9*	28' 8"		
0	NLC LC LC-V			22.0	35.9*	14.9	26.0	11.1	18.7	10.2	11.5*	10.2	11.5*	28'		
-5	NLC LC LC-V	17.2*	17.2*	31.1	35.8*	20.5	26.4*	15.2	20.9*	10.4	12.7*	12.8*	12.8*	26' 4"		
-10	NLC LC LC-V	32.6*	32.6*	21.9	34.3*	14.7	25.8	11.0	18.6	10.3	14.9*	11.3	14.9*	23' 5"		
-15	NLC LC LC-V	34.0*	34.0*	31.0	34.0*	20.4	25.7*	15.1	19.8*	14.3	15.1*	17.0	18.1*	16.5*	16.5*	18' 10"
-20	NLC LC LC-V			22.2	30.2*	14.8	22.9*			16.5*	16.5*	16.2*	16.2*			

## Stick 10'2"

ft	Under-carriage	10 ft		15 ft		20 ft		25 ft		30 ft		ft in
		LC	LC-V	LC	LC-V	LC	LC-V	LC	LC-V	LC	LC-V	
35	NLC LC LC-V											
30	NLC LC LC-V											
25	NLC LC LC-V									10.1*	10.1*	23'
20	NLC LC LC-V					17.8*	17.8*	12.5	15.4*	9.5*	9.5*	26' 5"
15	NLC LC LC-V					17.8*	17.8*	13.6	15.4*	9.5*	9.5*	28' 5"
10	NLC LC LC-V			24.2*	24.2*	20.0*	20.0*	16.4	17.8*	9.4*	9.4*	29' 6"
5	NLC LC LC-V			22.8	34.1*	15.4	24.8*	11.3	19.0	8.9	10.1*	29' 8"
0	NLC LC LC-V	18.1*	18.1*	21.9	35.7*	14.8	25.9	11.0	18.6	9.0	11.1*	29'
-5	NLC LC LC-V	31.3*	31.3*	21.7	34.6*	14.5	25.6	10.8	18.5	9.7	12.9*	27' 4"
-10	NLC LC LC-V	42.3*	42.3*	21.9	31.2*	14.6	23.5*			11.3	16.3*	24' 7"
-15	NLC LC LC-V	31.9*	31.9*	22.6	24.2*	15.2	16.9*			15.0	16.5*	20' 2"
-20	NLC LC LC-V			30.7*	30.7*					16.3*	16.3*	

## Stick 12'10"

ft	Under-carriage	10 ft		15 ft		20 ft		25 ft		30 ft		ft in						
		LC	LC-V	LC	LC-V	LC	LC-V	LC	LC-V	LC	LC-V							
35	NLC LC LC-V																	
30	NLC LC LC-V											8.4*	8.4*	21' 8"				
25	NLC LC LC-V									10.9*	10.9*	7.5*	7.5*	26' 2"				
20	NLC LC LC-V									11.5*	11.5*	7.4*	7.4*	29' 1"				
15	NLC LC LC-V							17.6*	17.6*	12.5	16.1*	9.2	10.8*	7.0*	7.0*	31'		
10	NLC LC LC-V	40.4*	40.4*	25.6	26.1*	16.7	20.5*	12.0	17.6*	17.6*	17.6*	13.5	16.1*	10.0	10.8*	7.0*	7.0*	32'
5	NLC LC LC-V	41.7*	41.7*	26.6*	26.6*	20.8*	20.8*	16.1	17.7*	12.2	14.5*	7.1*	7.1*	7.1*	7.1*	7.5*	7.5*	32' 1"
0	NLC LC LC-V	19.1*	19.1*	32.1*	32.1*	21.4	23.6*	15.5	19.2*	11.9	16.4*	7.5*	7.5*	7.9	8.2*	8.2*	8.2*	31' 6"
-5	NLC LC LC-V	28.8*	28.8*	21.6	35.4*	14.5	25.6	10.7	18.3	11.7	15.8*	8.2*	8.2*	8.4	9.3*	9.2	9.3*	30'
-10	NLC LC LC-V	40.1*	40.1*	21.6	33.3*	14.4	24.9*	10.7	18.3	11.7	15.8*	9.5	11.2*	10.4	11.2*	11.5*	11.5*	27' 6"
-15	NLC LC LC-V	39.3*	39.3*	22.0	28.4*	14.6	21.1*			11.8	15.4*	12.9	15.4*	16.0*	16.0*			23' 8"
-20	NLC LC LC-V			38.4*	38.4*	27.8*	27.8*	20.4	20.6*									

 Height 
  Can be slewed though 360° 
  In longitudinal position of undercarriage 
  Max. reach 
 \* Limited by hydr. capacity

The load values are quoted in lb x 1,000 at stick end (without bucket), and may be swung 360° on firm and even ground. Adjacent values are valid for the undercarriage when in the longitudinal position. Capacities are valid for 30" wide track pads. Indicated loads are based on ISO 10567 standard and do not exceed 75% of tipping or 87% of hydraulic capacity (indicated via \*). Without bucket cylinder, link and lever the lift capacities will increase by 880 lb. Lifting capacity of the excavator is limited by machine stability and hydraulic capacity.

# Backhoe Bucket

with Straight Mono Boom 21'4" and Counterweight 11,905 lb

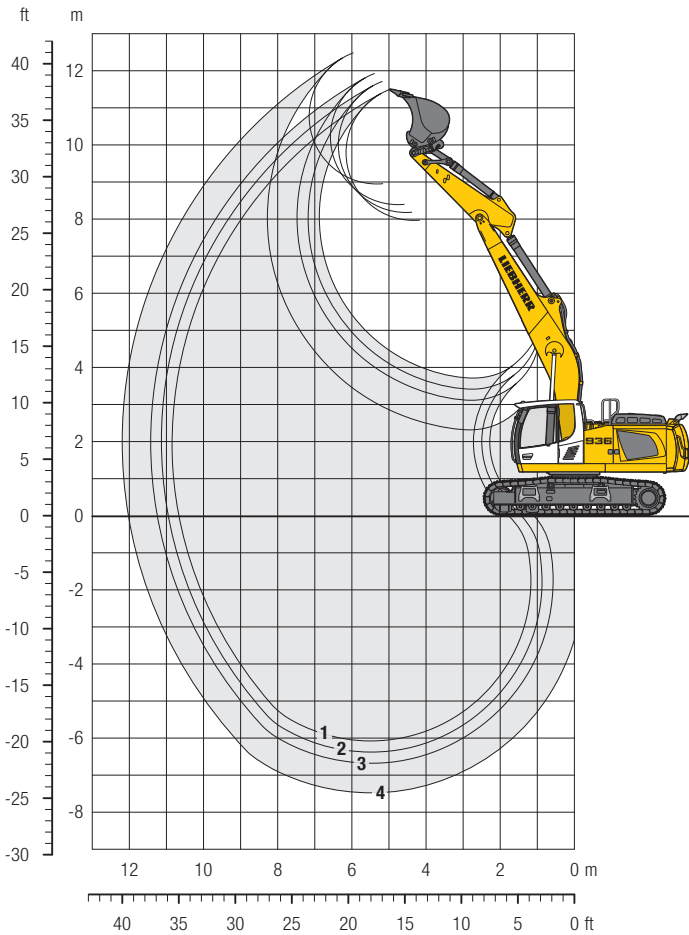

## Digging Envelope

with quick coupler		1	2	3	4
Stick length	ft in	8' 2"	9' 2"	10' 2"	12'10"
Max. digging depth	ft in	19'10"	20'10"	21'10"	24' 5"
Max. reach at ground level	ft in	34'11"	35'11"	36'11"	39' 4"
Max. dumping height	ft in	26' 1"	26' 9"	27' 7"	29' 4"
Max. teeth height	ft in	37' 9"	38' 5"	39' 1"	41'

## Digging Forces

with quick coupler		1	2	3	4
Digging force ISO	lbf	36,640	34,170	31,920	27,200
	lb	36,600	34,170	31,970	27,120
Breakout force ISO	lbf	40,240	40,240	40,240	40,240
	lb	40,120	40,120	40,120	40,120
without quick coupler					
Digging force ISO	lbf	38,670	35,970	33,500	28,330
	lb	38,580	35,940	33,510	28,220
Breakout force ISO	lbf	46,540	46,540	46,540	46,540
	lb	46,520	46,520	46,520	46,520

## Operating Weight and Ground Pressure

The operating weight includes the basic machine with counterweight 11,905 lb, straight mono boom 21'4", stick 8'2", quick coupler SW66 and bucket 1.31 yd<sup>3</sup> (2,115 lb).

Undercarriage		NLC			LC		
Pad width	in	20"	24"	30"	20"	24"	30"
Weight	lb	68,345	69,115	71,210	68,565	69,335	71,210
Ground pressure	psi	10.2	8.7	7.1	10.2	8.7	7.1

Undercarriage		LC-V		
Pad width	in	20"	24"	30"
Weight	lb	76,940	77,935	79,480
Ground pressure	psi	11.2	9.5	7.7

Optional: heavy counterweight

(counterweight 13,890 lb increases the operating weight by 1,985 lb and ground pressure by 0.3 psi) see load tables on page 27

## Buckets Machine stability per ISO 10567\* (75% of tipping capacity)

STD <sup>1)</sup>	Cutting width in	Capacity ISO 7451 yd <sup>3</sup>	Weight <sup>2)</sup> lb	Weight <sup>3)</sup> lb	NLC-Undercarriage								LC-Undercarriage								LC-V-Undercarriage							
					Stick length (ft in)				Stick length (ft in)				Stick length (ft in)				Stick length (ft in)				Stick length (ft in)							
					8'2"	9'2"	10'2"	12'10"	8'2"	9'2"	10'2"	12'10"	8'2"	9'2"	10'2"	12'10"	8'2"	9'2"	10'2"	12'10"	8'2"	9'2"	10'2"	12'10"				
					without quick coupler				with quick coupler				without quick coupler				with quick coupler				without quick coupler				with quick coupler			
41"	1.31	2,070	2,115	▲	▲	▲	▲	▲	▲	▲	▲	▲	▲	▲	▲	▲	▲	▲	▲	▲	▲	▲	▲					
49"	1.63	2,360	2,405	▲	▲	▲	■	▲	▲	▲	■	▲	▲	▲	▲	▲	▲	▲	▲	▲	▲	▲	▲					
55"	1.90	2,515	2,555	▲	▲	■	▲	▲	▲	■	■	▲	▲	▲	▲	▲	▲	▲	■	▲	▲	▲	■					
61"	2.09	2,670	2,710	▲	■	▲	△	■	▲	■	△	▲	▲	■	■	▲	▲	▲	■	▲	▲	▲	■					
65"	2.29	2,865	2,910	■	▲	▲	△	▲	▲	■	△	▲	▲	■	■	▲	▲	▲	■	▲	▲	▲	■					
61"	2.42	2,865	2,890	▲	■	■	△	■	■	△	—	■	■	▲	△	▲	▲	▲	■	▲	▲	▲	△					
65"	2.62	3,065	3,110	■	△	△	—	△	△	△	—	▲	▲	■	△	▲	▲	▲	△	▲	▲	▲	△					
69"	2.81	3,415	—	△	△	△	—	—	—	—	—	■	△	△	—	—	—	—	—	▲	▲	■	—					

\* Indicated loads are based on ISO 10567 max. stick length, lifted 360° on firm

<sup>1)</sup> Standard bucket with teeth Z 50

<sup>2)</sup> Bucket for direct fitting

<sup>3)</sup> Bucket for fitting to quick coupler (SW66, 772 lb)

Other backhoes available on request

Max. material weight ▲ = ≤ 3,371 lb/yd<sup>3</sup>, ■ = ≤ 3,034 lb/yd<sup>3</sup>, ▲ = ≤ 2,781 lb/yd<sup>3</sup>, ■ = ≤ 2,528 lb/yd<sup>3</sup>, △ = ≤ 2,023 lb/yd<sup>3</sup>, — = not authorized

# Lift Capacities

with Straight Mono Boom 21'4" and Counterweight 11,905 lb

## Stick 8'2"

ft	Under-carriage	10 ft		15 ft		20 ft		25 ft		30 ft		ft in
		LC	LC-V	LC	LC-V	LC	LC-V	LC	LC-V	LC	LC-V	
35	NLC LC LC-V											
30	NLC LC LC-V									15.5' 15.5'	15.5' 15.5'	17' 7"
25	NLC LC LC-V					17.7 19.3	20.8* 20.8*			13.2' 13.2'	13.2' 13.2'	22'11"
20	NLC LC LC-V			25.6* 25.9*	25.6* 25.9*	17.4 18.9	21.4* 21.5*	12.2 13.3	19.1* 19.1*	11.2 12.2	12.3* 12.3*	26' 4"
15	NLC LC LC-V			25.1 27.6	30.0* 30.0*	16.6 18.1	23.2* 23.2*	11.9 13.0	19.6* 19.6*	9.8 10.7	12.1* 12.1*	28' 4"
10	NLC LC LC-V			23.0 25.4	34.6* 34.6*	15.6 17.1	25.2* 25.2*	11.5 12.6	19.2 19.3	9.1 9.9	12.2* 12.2*	29' 5"
5	NLC LC LC-V			21.8 24.1	24.8* 24.8*	14.9 16.4	26.0 26.1	11.1 12.2	18.8 18.8	8.9 9.7	12.8* 12.8*	29' 7"
0	NLC LC LC-V			21.5 23.9	33.2* 33.2*	14.5 16.0	25.6 25.7	10.9 11.9	18.5 18.6	9.1 9.9	13.9* 13.9*	28'11"
- 5	NLC LC LC-V	22.2* 24.0*	22.2* 24.0*	21.7 24.0	29.9* 29.9*	14.5 15.9	23.9* 23.9*	10.9 11.9	18.5 18.5	9.8 10.8	15.8* 15.8*	27' 2"
- 10	NLC LC LC-V	22.1* 24.3*	24.3* 24.3*	22.1 24.3	14.7 16.2	19.6* 19.6*				11.5 12.6	14.0* 14.0*	24' 6"
- 15	NLC LC LC-V			23.7* 23.7*	23.7* 23.7*	19.1* 19.1*	19.1* 19.1*			13.8* 13.8*	13.8* 13.8*	
- 20	NLC LC LC-V											

## Stick 9'2"

ft	Under-carriage	10 ft		15 ft		20 ft		25 ft		30 ft		ft in
		LC	LC-V	LC	LC-V	LC	LC-V	LC	LC-V	LC	LC-V	
35	NLC LC LC-V											
30	NLC LC LC-V											13.3' 13.3'
25	NLC LC LC-V									17.9 19.4	19.9* 19.9*	13.3* 13.1* 13.1*
20	NLC LC LC-V									19.9* 19.9*	19.9* 19.9*	11.6* 11.6* 11.5*
15	NLC LC LC-V					25.6* 25.9*	25.6* 25.9*	18.9 18.2	21.4* 21.4*	12.3 12.3	18.5* 18.5*	10.8* 10.8* 10.8*
10	NLC LC LC-V					25.1 27.9	30.0* 30.0*	16.6 18.2	23.2* 23.2*	11.9 13.0	19.6* 19.6*	9.3 10.1
5	NLC LC LC-V					23.0 25.4	34.6* 34.6*	15.6 17.1	25.2* 25.2*	11.5 12.6	19.2 19.3	8.6 9.6
0	NLC LC LC-V					21.8 24.2	24.8* 24.8*	14.9 16.3	26.0 26.0	11.1 12.1	18.7 18.8	8.6 9.4
- 5	NLC LC LC-V	22.5* 23.9*	22.5* 23.9*	21.4 23.9	31.0* 31.0*	14.3 15.8	24.3* 24.3*	10.7 11.7	18.3 18.4	9.3 10.1	13.6* 13.6*	9.3 10.1
- 10	NLC LC LC-V	29.4* 29.4*	29.4* 29.4*	21.8 24.2	25.7* 25.7*	14.5 16.0	20.5* 20.5*	11.0 12.0	14.9* 14.9*	10.7 11.7	13.8* 13.8*	10.7 11.7
- 15	NLC LC LC-V			25.2* 25.2*	25.2* 25.2*	20.1* 20.1*	14.3* 14.3*	10.7 10.7	18.3 18.3	11.9 12.9	12.2* 12.2*	9.3 10.1
- 20	NLC LC LC-V									11.8 11.8	16.3* 16.3*	11.2* 11.2* 11.2*

## Stick 10'2"

ft	Under-carriage	10 ft		15 ft		20 ft		25 ft		30 ft		ft in
		LC	LC-V	LC	LC-V	LC	LC-V	LC	LC-V	LC	LC-V	
35	NLC LC LC-V											
30	NLC LC LC-V											11.6* 11.6*
25	NLC LC LC-V											11.6* 11.6* 11.4*
20	NLC LC LC-V											10.2* 10.2* 10.2*
15	NLC LC LC-V											9.6* 9.6* 9.5*
10	NLC LC LC-V											8.8* 8.8* 8.8*
5	NLC LC LC-V											8.4* 8.4* 9.4*
0	NLC LC LC-V											8.9 9.7 12.1
- 5	NLC LC LC-V	22.3* 23.4*	22.3* 23.4*	21.2 23.5	31.8* 31.8*	14.1 15.6	24.6* 24.6*	10.5 11.6	18.2 18.2	8.7 9.5	11.9* 11.9*	29' 4"
- 10	NLC LC LC-V	32.4* 31.7*	32.4* 31.7*	21.5 26.5	27.0* 26.5*	14.3 20.0	21.3* 20.9*	10.7 14.9	16.0* 15.6*	9.9 13.4	13.6* 13.4*	26' 8"
- 15	NLC LC LC-V			19.3* 19.3*	19.3* 19.3*	14.8 14.9*	14.9* 14.9*			11.9* 11.9*	11.9* 11.9*	22' 4"
- 20	NLC LC LC-V			18.5* 18.5*	18.5* 18.5*	14.1* 14.1*	14.1* 14.1*			12.6* 12.6*	12.6* 12.6*	

## Stick 12'10"

ft	Under-carriage	10 ft		15 ft		20 ft		25 ft		30 ft		ft in
		LC	LC-V	LC	LC-V	LC	LC-V	LC	LC-V	LC	LC-V	
35	NLC LC LC-V											10.3* 10.3* 10.0*
30	NLC LC LC-V											10.0* 8.4* 8.4*
25	NLC LC LC-V											8.3* 8.3* 7.5*
20	NLC LC LC-V											7.5* 7.5* 7.5*
15	NLC LC LC-V											14.8* 14.8* 14.8*
10	NLC LC LC-V											9.2 9.2
5	NLC LC LC-V											11.4* 11.4* 11.4*
0	NLC LC LC-V											11.7 11.7 11.7
- 5	NLC LC LC-V	13.0* 13.0*	13.0* 13.0*	21.2 21.2	31.8* 31.8*	14.1 15.6	24.6* 24.6*	10.5 11.6	18.2 18.2	8.7 9.5	11.9* 11.9*	7.1* 7.1* 7.1*
- 10	NLC LC LC-V	31.7* 31.7*	31.7* 31.7*	21.1 26.5	30.1* 26.5*	14.0 20.0	23.1* 20.9*	10.4 14.9	17.9* 17.9*	9.4 13.4	10.1* 10.1*	10.7 10.7
- 15	NLC LC LC-V	30.3* 30.3*	30.3* 30.3*	21.6 24.0	24.0* 24.0*	14.3 15.8	18.6* 18.6*	10.7 11.8	13.2* 13.2*	10.2 11.2	11.4* 11.4*	10.2* 10.2* 10.2*
- 20	NLC LC LC-V	29.3* 29.3*	29.3* 29.3*	23.3* 23.3*	23.3* 23.3*	18.1* 18.1*	12.6* 12.6*			11.2* 11.2*	11.2* 11.2*	11.2* 11.2* 11.2*

Height 
 Can be slewed though 360° 
 In longitudinal position of undercarriage 
 Max. reach 
 \* Limited by hydr. capacity

The load values are quoted in lb x 1,000 at stick end (without bucket), and may be swung 360° on firm and even ground. Adjacent values are valid for the undercarriage when in the longitudinal position. Capacities are valid for 30" wide track pads. Indicated loads are based on ISO 10567 standard and do not exceed 75% of tipping or 87% of hydraulic capacity (indicated via \*). Without bucket cylinder, link and lever the lift capacities will increase by 880 lb. Lifting capacity of the excavator is limited by machine stability and hydraulic capacity.

# Backhoe Bucket

with Two-Piece Boom 13'9" and Counterweight 13,890 lb

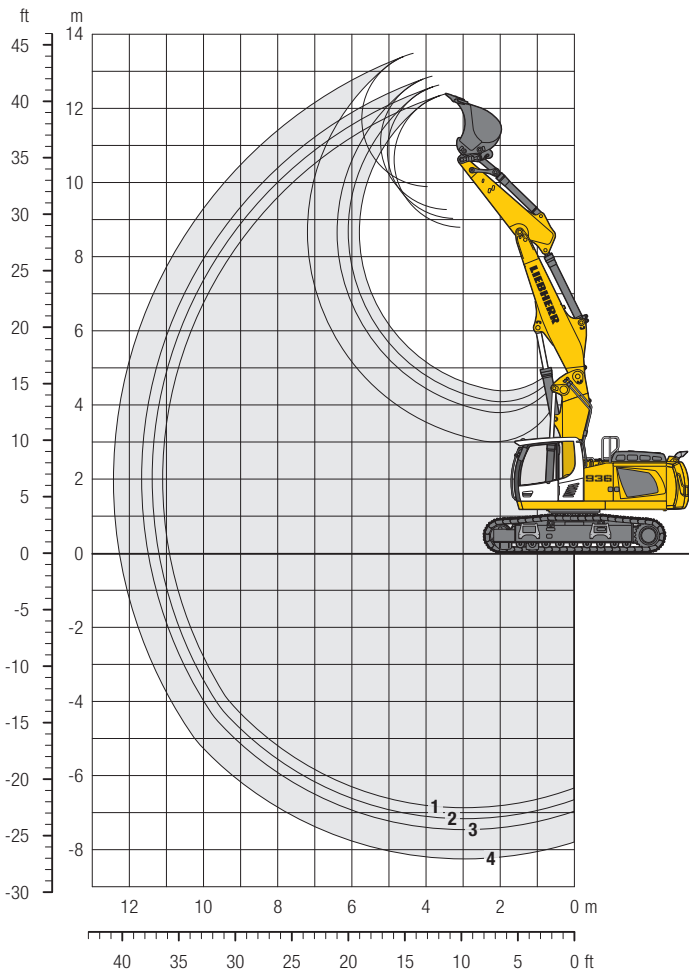

## Digging Envelope

with quick coupler		1	2	3	4
Stick length	ft in	8'2"	9'2"	10'2"	12'10"
Max. digging depth	ft in	22'6"	23'5"	24'5"	27' 1"
Max. reach at ground level	ft in	35'9"	36'9"	37'9"	40' 2"
Max. dumping height	ft in	28'8"	29'6"	30'4"	32' 6"
Max. teeth height	ft in	40'8"	41'4"	42'2"	44' 3"

## Digging Forces

with quick coupler		1	2	3	4
Digging force ISO	lbf	36,640	34,170	31,920	27,200
	lb	36,600	34,170	31,970	27,120
Breakout force ISO	lbf	40,240	40,240	40,240	40,240
	lb	40,120	40,120	40,120	40,120
without quick coupler					
Digging force ISO	lbf	38,670	35,970	33,500	28,330
	lb	38,580	35,940	33,510	28,220
Breakout force ISO	lbf	46,540	46,540	46,540	46,540
	lb	46,520	46,520	46,520	46,520

## Operating Weight and Ground Pressure

The operating weight includes the basic machine with counterweight 13,890 lb, two-piece boom 13'9", stick 8'2", quick coupler SW66 and bucket 1.31 yd<sup>3</sup> (2,115 lb).

Undercarriage		NLC			LC		
Pad width	in	20"	24"	30"	20"	24"	30"
Weight	lb	74,185	74,960	77,050	74,405	75,180	77,270
Ground pressure	psi	11.1	9.4	7.7	11.1	9.4	7.7

Undercarriage		LC-V		
Pad width	in	20"	24"	30"
Weight	lb	82,785	83,775	85,210
Ground pressure	psi	12.1	10.2	8.2

## Buckets Machine stability per ISO 10567\* (75% of tipping capacity)

STD <sup>1)</sup>	Cutting width in	Capacity ISO 7451 yd <sup>3</sup>	Weight <sup>2)</sup> lb	Weight <sup>3)</sup> lb	NLC-Undercarriage								LC-Undercarriage								LC-V-Undercarriage							
					Stick length (ft in)				Stick length (ft in)				Stick length (ft in)				Stick length (ft in)				Stick length (ft in)							
					8'2"	9'2"	10'2"	12'10"	8'2"	9'2"	10'2"	12'10"	8'2"	9'2"	10'2"	12'10"	8'2"	9'2"	10'2"	12'10"	8'2"	9'2"	10'2"	12'10"	8'2"	9'2"	10'2"	12'10"
					without quick coupler				with quick coupler				without quick coupler				with quick coupler				without quick coupler				with quick coupler			
41"	1.31	2,070	2,115	▲	▲	▲	▲	▲	▲	▲	▲	▲	▲	▲	▲	▲	▲	▲	▲	▲	▲	▲	▲	▲	▲			
49"	1.63	2,360	2,405	▲	▲	▲	■	▲	▲	▲	▲	▲	▲	▲	▲	▲	▲	▲	▲	▲	▲	▲	▲	▲	▲			
55"	1.90	2,515	2,555	▲	▲	■	▲	▲	■	■	■	▲	▲	▲	▲	▲	▲	▲	▲	▲	▲	▲	▲	▲	■			
61"	2.09	2,670	2,710	▲	■	▲	△	■	▲	■	△	▲	▲	■	▲	■	■	■	▲	▲	▲	▲	▲	▲	▲			
65"	2.29	2,865	2,910	■	▲	■	△	▲	■	△	-	▲	■	▲	■	▲	▲	△	▲	▲	▲	■	▲	▲	△			
61"	2.42	2,865	2,890	▲	■	△	△	■	△	△	-	■	▲	△	■	▲	■	△	▲	▲	▲	▲	▲	▲	△			
65"	2.62	3,065	3,110	■	▲	△	△	△	△	△	-	▲	■	■	▲	■	▲	△	▲	▲	▲	■	▲	▲	△			
69"	2.81	3,415	-	△	△	-	-	-	-	-	-	■	△	△	-	-	-	-	▲	▲	■	△	-	-	-			

\* Indicated loads are based on ISO 10567 max. stick length, lifted 360° on firm

<sup>1)</sup> Standard bucket with teeth Z 50

<sup>2)</sup> Bucket for direct fitting

<sup>3)</sup> Bucket for fitting to quick coupler (SW66, 772 lb)

Other backhoes available on request

Max. material weight ▲ = ≤ 3,371 lb/yd<sup>3</sup>, ■ = ≤ 3,034 lb/yd<sup>3</sup>, ▲ = ≤ 2,781 lb/yd<sup>3</sup>, ■ = ≤ 2,528 lb/yd<sup>3</sup>, △ = ≤ 2,023 lb/yd<sup>3</sup>, - = not authorized





# Lift Capacities

with Mono Boom 19'10" and Counterweight 13,890 lb

## Stick 8'2"

ft	Under-carriage	10 ft		15 ft		20 ft		25 ft		30 ft		ft in
35	NLC LC LC-V											
30	NLC LC LC-V											
25	NLC LC LC-V					16.8* 16.8*	16.8* 16.8*			13.1* 13.1*	13.1* 13.1*	20' 7"
20	NLC LC LC-V					19.0 19.6*	19.6* 19.6*			12.3* 12.3*	12.3* 12.3*	24' 4"
15	NLC LC LC-V	39.7* 39.7*	39.7* 39.7*	26.4* 26.4*	26.4* 26.4*	18.3* 18.3*	21.4* 21.4*	13.1 19.8	19.0* 21.4*	12.0* 12.1*	12.1* 12.1*	26' 6"
10	NLC LC LC-V	41.4* 41.4*	41.4* 41.4*	26.8* 26.8*	26.8* 26.8*	21.6* 21.6*	21.6* 21.6*	17.4 17.4	19.1* 19.1*	12.1* 12.1*	12.1* 12.1*	27' 7"
5	NLC LC LC-V			25.9 28.4	32.0* 32.0*	17.4 19.0	23.8* 23.8*	12.7 13.8	19.9* 19.9*	11.0 12.0	12.4* 12.4*	27' 10"
0	NLC LC LC-V			23.9 33.3	35.9* 35.8*	16.2 22.0	26.6* 26.6*	12.1 16.3	20.1 20.9*	11.0 14.8	14.7* 14.8*	27' 1"
-5	NLC LC LC-V	33.9* 33.9*	33.9* 33.9*	23.9 26.4	33.7* 33.7*	16.1 17.6	25.6* 25.6*	12.1 13.2	19.5* 19.5*	12.0 13.0	17.4* 17.4*	25' 4"
-10	NLC LC LC-V	37.4* 37.4*	37.4* 37.4*	24.3 26.8	29.2* 29.2*	16.3 17.8	22.1* 22.1*			14.3 15.6	18.6* 18.6*	22' 4"
-15	NLC LC LC-V	36.7* 36.7*	36.7* 36.7*	28.6* 28.6*	20.0* 20.0*	21.6* 21.6*				17.4* 17.4*	17.4* 17.4*	16' 8"
-20	NLC LC LC-V											

## Stick 9'2"

ft	Under-carriage	10 ft		15 ft		20 ft		25 ft		30 ft		ft in
35	NLC LC LC-V											
30	NLC LC LC-V											
25	NLC LC LC-V							18.4* 18.4*	18.4* 18.4*			11.5* 11.5*
20	NLC LC LC-V							18.7* 18.7*	18.7* 18.7*	12.9* 12.9*	12.9* 12.9*	21' 10"
15	NLC LC LC-V							25.1* 25.1*	25.1* 25.1*	20.8* 20.8*	20.8* 20.8*	25' 4"
10	NLC LC LC-V	37.4* 37.4*	37.4* 37.4*	25.5* 25.5*	25.5* 25.5*	20.8* 20.8*	20.8* 20.8*	17.4 17.4	18.4* 18.4*	14.1* 14.1*	14.1* 14.1*	25' 4"
5	NLC LC LC-V			26.1 28.7	30.8* 30.8*	17.5 19.0	23.1* 23.1*	12.7 13.8	19.4* 19.4*	10.5 10.8	10.8* 10.8*	28' 6"
0	NLC LC LC-V			24.5 33.9	34.9* 35.1*	16.6 22.5	25.4* 25.5*	12.3 16.5	20.3 20.5*	10.2 11.1	11.5* 11.5*	28' 8"
-5	NLC LC LC-V			23.8 32.6	35.9* 35.9*	16.1 21.9	26.4* 26.4*	12.0 16.2	20.0 20.9*	10.4 11.3	12.7* 12.7*	28'
-10	NLC LC LC-V	32.6* 32.6*	32.6* 32.6*	23.7 26.2	34.3* 34.3*	15.9 17.4	25.8* 25.8*	12.0 13.0	19.9* 19.9*	11.2 12.2	14.9* 14.9*	26' 4"
-15	NLC LC LC-V	40.0* 40.0*	40.0* 40.0*	24.0 26.5	30.2* 30.2*	16.1 17.6	22.9* 22.9*			13.2 14.4	18.1* 18.1*	23' 5"
-20	NLC LC LC-V	39.3* 39.3*	39.3* 39.3*	29.8* 29.8*	22.3* 22.3*	22.3* 22.3*				16.5* 16.5*	16.5* 16.5*	18' 10"
-20	NLC LC LC-V									16.2* 16.2*	16.2* 16.2*	

## Stick 10'2"

ft	Under-carriage	10 ft		15 ft		20 ft		25 ft		30 ft		ft in
35	NLC LC LC-V											
30	NLC LC LC-V											
25	NLC LC LC-V									10.1* 10.1*	10.1* 10.1*	23'
20	NLC LC LC-V					17.8* 17.8*	17.8* 17.8*	13.4 14.5	15.4* 15.4*	9.5* 9.5*	9.5* 9.5*	26' 5"
15	NLC LC LC-V					19.8* 19.8*	19.8* 19.8*	14.3 14.3	17.7* 17.7*	9.4* 9.4*	9.4* 9.4*	28' 5"
10	NLC LC LC-V			24.2* 24.2*	24.2* 24.2*	20.0* 20.0*	20.0* 20.0*	17.4 17.4	17.8* 17.8*	9.4* 9.4*	9.4* 9.4*	29' 6"
5	NLC LC LC-V			24.6 27.1	34.1* 34.1*	16.6 18.2	24.8* 24.8*	12.3 13.3	20.1* 20.1*	9.6 10.1*	9.6 10.1*	29' 8"
0	NLC LC LC-V	18.1* 18.1*	18.1* 18.1*	23.7 26.2	35.7* 35.7*	16.0 17.5	26.1* 26.1*	11.9 13.0	19.9 19.9	9.8 10.7	11.1* 11.1*	29'
-5	NLC LC LC-V	31.3* 31.3*	31.3* 31.3*	23.5 26.0	34.6* 34.6*	15.8 17.3	25.9* 25.9*	11.8 12.9	19.7 19.8	10.6 11.5	12.9* 12.9*	27' 4"
-10	NLC LC LC-V	42.3* 42.3*	42.3* 42.3*	23.7 26.2	31.2* 31.2*	15.9 17.4	23.5* 23.5*			12.3 13.4	16.3* 16.3*	24' 7"
-15	NLC LC LC-V	31.9* 31.9*	31.9* 31.9*	24.2* 24.2*	24.2* 24.2*	16.5 16.9*	16.9* 16.9*			16.3 16.5*	16.5* 16.5*	20' 2"
-20	NLC LC LC-V	30.7* 30.7*	30.7* 30.7*	23.4* 23.4*						16.3* 16.3*		

## Stick 12'10"

ft	Under-carriage	10 ft		15 ft		20 ft		25 ft		30 ft		ft in
35	NLC LC LC-V											
30	NLC LC LC-V											8.4* 8.4* 8.2*
25	NLC LC LC-V									10.9* 10.9*	10.9* 10.9*	21' 8"
20	NLC LC LC-V									13.8 14.9	15.1* 15.1*	29' 1"
15	NLC LC LC-V							17.6* 17.6*	17.6* 17.6*	13.4 14.5	16.1* 16.1*	31'
10	NLC LC LC-V	40.4* 40.4*	40.4* 40.4*	26.1* 26.1*	26.1* 26.1*	17.9 19.5	20.5* 20.5*	12.9 14.0	17.6* 17.6*	10.0 10.6	10.8* 10.8*	32'
5	NLC LC LC-V	19.5* 19.5*	19.5* 19.5*	25.3 27.8	31.8* 31.8*	16.9 18.5	23.4* 23.4*	12.4 13.5	19.1* 19.1*	9.5 10.3	15.5* 15.5*	32' 1"
0	NLC LC LC-V	21.0* 21.0*	21.0* 21.0*	24.0 26.5	35.0* 35.0*	16.1 17.7	25.4* 25.4*	11.9 13.0	19.9 20.0	9.3 10.1	15.3* 15.3*	31' 6"
-5	NLC LC LC-V	28.8* 28.8*	28.8* 28.8*	23.4 25.9	35.4* 35.4*	15.7 17.2	26.0* 26.0*	11.7 12.7	19.6* 19.6*	9.2 9.3*	9.3* 9.3*	30'
-10	NLC LC LC-V	40.1* 40.1*	40.1* 40.1*	23.4 25.9	33.3* 33.3*	15.6 17.1	24.9* 24.9*	11.6 12.7	19.1* 19.1*	10.3 11.2	11.2* 11.2*	27' 6"
-15	NLC LC LC-V	39.3* 39.3*	39.3* 39.3*	23.8 26.3	28.4* 28.4*	15.9 17.4	21.1* 21.1*			12.8 14.0	15.4* 15.4*	23' 8"
-20	NLC LC LC-V	38.4* 38.4*	38.4* 38.4*	27.8* 27.8*						16.0* 16.0*		

Height Can be slewed through 360° In longitudinal position of undercarriage Max. reach \* Limited by hydr. capacity

The load values are quoted in lb x 1,000 at stick end (without bucket), and may be swung 360° on firm and even ground. Adjacent values are valid for the undercarriage when in the longitudinal position. Capacities are valid for 30" wide track pads. Indicated loads are based on ISO 10567 standard and do not exceed 75% of tipping or 87% of hydraulic capacity (indicated via \*). Without bucket cylinder, link and lever the lift capacities will increase by 880 lb. Lifting capacity of the excavator is limited by machine stability and hydraulic capacity.

# Lift Capacities

with Straight Mono Boom 21'4" and Counterweight 13,890 lb

## Stick 8'2"

ft	Under-carriage	10 ft		15 ft		20 ft		25 ft		30 ft		ft in
35	NLN LC LC-V											
30	NLN LC LC-V									15.5' 15.5' 15.2'	15.5' 15.5' 17' 7"	
25	NLN LC LC-V				19.0 20.6 20.7*	20.8* 20.8*					13.2' 13.2' 13.1'	22'11"
20	NLN LC LC-V			25.6' 25.6'	25.6' 25.9'	18.6 21.5*	21.4' 21.5*	13.2 17.4	19.1* 19.1*		12.1 12.3'	26' 4"
15	NLN LC LC-V			27.0 29.6	30.0' 30.0'	17.8 19.4	23.2' 23.2'	12.9 14.0	19.6* 19.6*		10.6 11.5	28' 4"
10	NLN LC LC-V			24.8 27.3	34.6' 34.6'	16.9 18.4	25.2' 25.2'	12.5 13.5	20.4* 20.4*		9.9 10.7	29' 5"
5	NLN LC LC-V			23.6 24.8*	24.8' 24.8'	16.2 17.7	26.3' 26.3'	12.1 13.1	20.0 20.1		9.7 10.5	29' 7"
0	NLN LC LC-V			23.4 25.8	33.2' 33.2'	15.8 17.3	25.9' 25.9'	11.8 12.9	18.5* 19.8		9.9 10.8	28'11"
-5	NLN LC LC-V	22.2' 22.2' 24.0*	22.2' 22.2' 24.0*	23.5 26.0	29.9' 29.9'	15.7 17.2	23.9' 23.9'	11.8 12.9	18.5* 18.5*		10.7 11.7	27' 2"
-10	NLN LC LC-V			23.9 24.3*	24.3' 24.3'	16.0 17.5	19.6' 19.6*				12.5 13.6	24' 6"
-15	NLN LC LC-V			23.7*	23.7*	19.1*	19.1*				13.8*	13.8*
-20	NLN LC LC-V											

## Stick 9'2"

ft	Under-carriage	10 ft		15 ft		20 ft		25 ft		30 ft		ft in
35	NLN LC LC-V											
30	NLN LC LC-V										13.3' 13.3' 13.1'	19' 2"
25	NLN LC LC-V						19.1 19.9* 19.9*	19.9* 19.9* 19.9*			11.6' 11.6' 11.5'	24' 1"
20	NLN LC LC-V			25.6' 25.9'	25.6' 25.9'	21.5* 21.5*	21.5* 21.5*	17.4 17.4	19.1* 19.1*		12.3' 12.3'	27' 4"
15	NLN LC LC-V			27.0 29.6	30.0' 30.0'	17.8 19.4	23.2' 23.2'	12.9 14.0	19.6* 19.6*		10.6 11.5	29' 4"
10	NLN LC LC-V			24.8 27.3	34.6' 34.6'	16.9 18.4	25.2' 25.2'	12.5 13.5	20.4* 20.4*		9.9 10.7	30' 4"
5	NLN LC LC-V			23.6 24.8*	24.8' 24.8'	16.2 17.7	26.3' 26.3'	12.1 13.1	20.0 20.1		9.7 10.5	30' 6"
0	NLN LC LC-V			23.4 25.8	33.2' 33.2'	15.8 17.3	25.9' 25.9'	11.8 12.9	18.5* 19.8		9.9 10.8	29'10"
-5	NLN LC LC-V	22.5' 22.5' 23.9*	22.5' 22.5' 23.9*	23.3 26.0	31.0' 31.0'	15.7 17.2	23.9' 23.9'	11.7 12.9	18.5* 18.5*		11.7 13.4	28' 4"
-10	NLN LC LC-V			23.9 24.3*	24.3' 24.3'	16.0 17.5	19.6' 19.6*				12.5 13.6	25' 7"
-15	NLN LC LC-V			23.7*	23.7*	19.1*	19.1*				13.8*	13.8*
-20	NLN LC LC-V											

## Stick 10'2"

ft	Under-carriage	10 ft		15 ft		20 ft		25 ft		30 ft		ft in
35	NLN LC LC-V											
30	NLN LC LC-V					14.6' 14.6'	14.6' 15.9*				11.6' 11.6'	20' 7"
25	NLN LC LC-V					19.0' 19.0'	19.0' 19.0'	12.2' 12.2'	12.2*		10.2' 10.2'	25' 4"
20	NLN LC LC-V					18.8 19.9*	18.8 19.9*	13.3 14.4	17.9* 17.9*		9.6' 9.6'	28' 5"
15	NLN LC LC-V			27.6 27.6*	27.6' 27.6'	18.0 19.6	21.8* 21.8*	12.9 14.0	18.6* 18.6*	9.7 10.5	9.4' 9.4'	30' 4"
10	NLN LC LC-V			25.3 27.8	32.6' 32.6'	17.0 18.5	24.0* 24.0*	12.4 13.5	19.6* 19.6*	9.5 10.3	8.9 9.4'	31' 4"
5	NLN LC LC-V			23.7 26.2	35.3' 35.3'	16.1 17.6	25.7* 25.7*	11.9 13.0	19.9* 19.9*	9.3 10.1	8.7 9.5	31' 6"
0	NLN LC LC-V			23.1 25.5	34.7' 34.7'	15.6 17.1	25.9* 25.9*	11.6 12.7	19.5 19.6	9.2 10.0	8.9 9.7	30'10"
-5	NLN LC LC-V	22.3' 22.3' 23.4*	22.3' 22.3' 23.4*	23.0 25.5	31.8' 31.8'	15.4 16.9	24.6* 24.6*	11.5 12.6	19.2* 19.2*		9.5 10.3	29' 4"
-10	NLN LC LC-V			32.4 32.4*	32.4' 32.4'	23.3 25.8	27.0* 27.0*	15.5 17.0	21.3* 21.3*	11.7 12.7	16.0* 16.0*	26' 8"
-15	NLN LC LC-V			19.3*	19.3*	14.9*	14.9*				11.9*	22' 4"
-20	NLN LC LC-V										12.6*	12.6*

## Stick 12'10"

ft	Under-carriage	10 ft		15 ft		20 ft		25 ft		30 ft		ft in
35	NLN LC LC-V										10.3' 10.3' 10.0'	18'
30	NLN LC LC-V										8.4' 8.4' 8.3'	24' 4"
25	NLN LC LC-V							13.7 14.6* 14.8*	14.6* 14.6*		7.5' 7.5' 7.5'	28' 5"
20	NLN LC LC-V						17.4* 17.4*	17.4* 17.4*	17.4* 17.4*	10.0 10.0	11.4* 11.4*	31' 2"
15	NLN LC LC-V			22.9* 22.9*	22.9* 22.9*	22.9* 22.9*	20.0* 20.0*	13.1 14.2	17.4* 17.4*	9.8 10.7	15.3* 15.3*	32'11"
10	NLN LC LC-V			26.3 28.9	32.6' 32.6'	17.0 18.5	24.0* 24.0*	12.6 13.7	18.6* 18.6*	9.6 10.4	15.6 15.7	33'10"
5	NLN LC LC-V			24.3 26.8	34.0' 34.0'	16.4 17.9	24.7* 24.7*	12.0 13.1	19.8* 19.8*	9.3 10.1	15.3 15.4	34'
0	NLN LC LC-V			13.0* 13.0*	13.0* 13.0*	23.2 25.7	35.2* 35.2*	15.7 17.2	25.8* 25.8*	11.6 12.7	19.6 19.6	33' 5"
-5	NLN LC LC-V	21.2* 21.2* 22.0*	21.2* 21.2* 22.0*	22.8 25.3	33.7' 33.7'	16.8 18.3	25.3* 25.3*	11.4 12.4	19.3 19.3	8.9 9.8	14.9 15.0	32'
-10	NLN LC LC-V	31.7* 31.7* 32.7*	31.7* 31.7* 32.7*	22.9 25.4	30.1* 30.1*	15.3 16.8	23.1* 23.1*	11.4 12.4	17.9* 17.9*		10.1 10.2	29' 8"
-15	NLN LC LC-V			30.3* 30.3* 29.3*	30.3* 30.3* 29.3*	23.4 24.0*	24.0* 24.0*	15.6 17.1	18.6* 18.6*	11.7 12.8	13.2* 13.2*	26' 2"
-20	NLN LC LC-V							12.6*	12.6*		11.2*	11.2*

Height Can be slewed though 360° In longitudinal position of undercarriage Max. reach \* Limited by hydr. capacity

The load values are quoted in lb x 1,000 at stick end (without bucket), and may be swung 360° on firm and even ground. Adjacent values are valid for the undercarriage when in the longitudinal position. Capacities are valid for 30" wide track pads. Indicated loads are based on ISO 10567 standard and do not exceed 75% of tipping or 87% of hydraulic capacity (indicated via \*). Without bucket cylinder, link and lever the lift capacities will increase by 880 lb. Lifting capacity of the excavator is limited by machine stability and hydraulic capacity.

# Available HD Buckets

## Buckets Machine stability per ISO 10567\* (75% of tipping capacity)

Cutting width in	Capacity ISO 7451 yd <sup>3</sup>	Weight <sup>2)</sup> lb	Weight <sup>3)</sup> lb	NLC-Undercarriage								LC-Undercarriage								LC-V-Undercarriage							
				Stick length (ft in)				Stick length (ft in)				Stick length (ft in)				Stick length (ft in)				Stick length (ft in)							
				8'2" without quick coupler	9'2" with quick coupler	10'2" without quick coupler	12'10" with quick coupler	8'2" without quick coupler	9'2" with quick coupler	10'2" without quick coupler	12'10" with quick coupler	8'2" without quick coupler	9'2" with quick coupler	10'2" without quick coupler	12'10" with quick coupler	8'2" without quick coupler	9'2" with quick coupler	10'2" without quick coupler	12'10" with quick coupler	8'2" without quick coupler	9'2" with quick coupler	10'2" without quick coupler	12'10" with quick coupler				
<b>Mono boom 19'10"</b>																											
41"	1.31	2,425	2,470	▲	▲	▲	▲	▲	▲	▲	▲	▲	▲	▲	▲	▲	▲	▲	▲	▲	▲	▲	▲	▲	▲		
49"	1.63	2,755	2,800	▲	▲	▲	■	▲	▲	▲	▲	▲	▲	▲	▲	▲	▲	▲	▲	▲	▲	▲	▲	▲	▲		
55"	1.90	2,955	3,000	▲	▲	▲	■	▲	▲	▲	▲	▲	■	▲	▲	▲	▲	▲	▲	▲	▲	▲	▲	▲	▲		
61"	2.09	3,155	3,200	▲	▲	■	■	▲	▲	■	■	▲	▲	▲	▲	▲	■	▲	▲	▲	▲	▲	▲	▲	■		
65"	2.29	3,395	3,440	▲	■	▲	△	■	▲	▲	△	▲	▲	■	■	▲	▲	■	△	▲	▲	▲	■	▲	△		
61"	2.42	3,330	3,350	■	■	▲	△	■	▲	■	△	▲	▲	■	△	▲	■	▲	△	▲	▲	▲	△	▲	△		
65"	2.62	3,570	3,615	▲	■	■	△	▲	■	△	-	■	■	▲	△	■	▲	■	-	▲	▲	▲	△	▲	▲		
69"	2.81	3,970	-	■	△	△	-	-	-	-	-	▲	▲	■	-	-	-	-	-	▲	▲	■	-	-	-		
<b>Straight mono boom 21'4"</b>																											
41"	1.31	2,425	2,470	▲	▲	▲	▲	▲	▲	▲	▲	▲	▲	▲	▲	▲	▲	▲	▲	▲	▲	▲	▲	▲	▲		
49"	1.63	2,755	2,800	▲	▲	▲	■	▲	▲	▲	▲	▲	▲	▲	▲	▲	▲	▲	▲	▲	▲	▲	▲	▲	▲		
55"	1.90	2,955	3,000	▲	▲	■	■	▲	■	▲	△	▲	▲	▲	▲	■	■	▲	▲	▲	■	▲	▲	▲	▲		
61"	2.09	3,155	3,200	■	■	▲	△	■	▲	■	△	▲	▲	■	■	▲	■	▲	△	▲	▲	▲	▲	▲	■		
65"	2.29	3,395	3,440	▲	■	▲	△	■	▲	△	-	■	■	▲	△	■	▲	■	△	▲	▲	▲	▲	▲	△		
61"	2.42	3,330	3,350	▲	■	▲	-	■	▲	△	-	■	▲	■	△	▲	▲	■	△	▲	▲	▲	▲	▲	△		
65"	2.62	3,570	3,615	■	△	△	-	△	△	-	-	▲	▲	△	△	■	▲	△	△	-	▲	▲	▲	△	▲		
69"	2.81	3,970	-	△	△	-	-	-	-	-	-	■	△	△	-	-	-	-	-	▲	■	■	-	-	-		
<b>Two-piece boom 13'9"</b>																											
41"	1.31	2,425	2,470	▲	▲	▲	▲	▲	▲	▲	▲	▲	▲	▲	▲	▲	▲	▲	▲	▲	▲	▲	▲	▲	▲		
49"	1.63	2,755	2,800	▲	▲	▲	■	▲	▲	▲	▲	▲	▲	▲	▲	▲	▲	▲	▲	▲	▲	▲	▲	▲	▲		
55"	1.90	2,955	3,000	▲	▲	■	■	▲	■	▲	△	▲	▲	▲	▲	■	■	▲	▲	▲	■	▲	▲	▲	▲		
61"	2.09	3,155	3,200	■	▲	■	△	▲	■	■	△	▲	▲	■	■	▲	■	▲	△	▲	▲	▲	▲	▲	■		
65"	2.29	3,395	3,440	▲	■	▲	△	■	▲	△	-	■	▲	▲	△	■	▲	■	△	▲	▲	▲	■	▲	△		
61"	2.42	3,330	3,350	■	■	▲	-	■	▲	△	-	■	▲	■	△	▲	■	△	△	▲	▲	▲	▲	▲	△		
65"	2.62	3,570	3,615	△	△	△	-	△	△	-	-	▲	■	△	△	■	▲	△	△	-	▲	▲	■	△	▲		
69"	2.81	3,970	-	△	△	-	-	-	-	-	-	△	△	△	-	-	-	-	-	▲	■	▲	-	-	-		

\* Indicated loads are based on ISO 10567 max. stick length, lifted 360° on firm

<sup>1)</sup> HD bucket with teeth Z 50

<sup>2)</sup> Bucket for direct fitting

<sup>3)</sup> Bucket for fitting to quick coupler (SW66, 772 lb)

Other backhoes available on request

Max. material weight ▲ = ≤ 3,371 lb/yd<sup>3</sup>, ■ = ≤ 3,034 lb/yd<sup>3</sup>, ▲ = ≤ 2,781 lb/yd<sup>3</sup>, ■ = ≤ 2,528 lb/yd<sup>3</sup>, △ = ≤ 2,023 lb/yd<sup>3</sup>, - = not authorized

# Available Tools

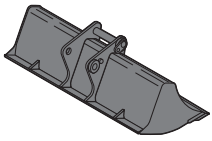

## Rigid Ditch Cleaning Bucket

**GRL 100, for mounting to quick coupler SW66**

Cutting width	in	79"	94"	94"
Capacity	yd <sup>3</sup>	0.92	1.11	1.63
Weight	lb	1,215	1,410	1,520

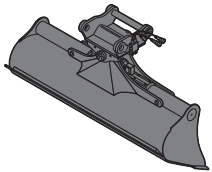

## Ditch Cleaning Bucket

**GRL 100, 2 x 50° tiltable, for mounting to quick coupler SW66**

Cutting width	in	79"	79"	87"*	94"*	94"*
Capacity	yd <sup>3</sup>	0.92	1.90	2.16	1.11	1.90
Weight	lb	3,086	3,527	3,660	3,265	3,550

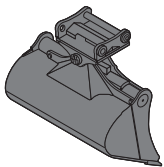

## Tilt Bucket

**SL 100, 2 x 50° tiltable, for mounting to quick coupler SW66**

Cutting width	in	63"	63"	71"	71"*
Capacity	yd <sup>3</sup>	1.50	1.90	2.09	2.09
Weight	lb	3,350	3,350	3,570	–
Weight in HD-version	lb	–	–	–	3,860

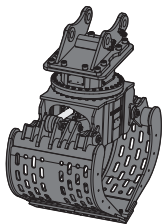

## Sorting Grab

**SG 40, for mounting to quick coupler SW66**

		ribbed	perforated	Gravel tongs
Cutting width	in	43"*	43"*	47"*
Capacity	yd <sup>3</sup>	1.44	1.70	1.70
Weight	lb	5,115	4,915	5,205

\* also available for SW48

# Standard Equipment

## Undercarriage

Lashing eyelets  
Sprocket with dirt ejector  
Track guide (one piece per track frame)  
Track rollers, lifetime-lubricated  
Tracks, sealed and greased

## Uppercarriage

Engine hood with gas spring opening  
Handrails  
Manual main switch  
Non slip surfaces  
Right-hand rearview mirror  
Sound insulation  
Storage box, lockable  
Swing brake lock, maintenance-free  
Swing drive oil tank  
Tool set 29 pieces

## Hydraulic System

Filter with integrated fine filter area  
Liebherr hydraulic oil  
Positive Control system  
Pressure storage for controlled lowering of equipment with engine turned off  
Pressure test ports for hydraulic  
Separate swing circuit  
Shut-off valve between hydraulic tank and pumps  
Work mode selector

## Engine

Common-Rail injection system  
Conform with stage IV/Tier 4f emission standard  
Engine idling, automatic, sensor-controlled  
Fixed geometry turbo charger  
Fuel filter and water separator  
Intercooler  
Liebherr SCR technology  
Stepless adjustable engine speed

## Operator's Cab

7" color multifunction display with touchscreen  
Air conditioning, automatic  
Cigarette lighter and ashtray  
Coat hook  
Cup holder  
Fuel consumption indicator on touchscreen  
Headlights (two pieces, Halogen)  
Hydraulic suspension  
Interior light  
LiDAT Plus (Liebherr data transfer system)\*  
Mechanical hour meters, readable from outside the cab  
Oil level monitoring on touchscreen  
Operator seat "Comfort" with horizontal and vertical damping  
Preparation for radio installation  
Rain hood over front window opening  
Rearview mirrors  
Rear view monitoring camera  
Rear window emergency exit  
Retractable seat belt 6'7"  
Roll-down sun blind  
Roof window, right window and windshield with safety glass  
ROPS safety cab structure (ISO 12117-2)  
Rubber floor mat  
Sliding windows in cab door  
Storage bin  
Storage space  
Tinted windows  
Urea tank level monitoring on touchscreen  
Windscreen, totally or partially retractable  
Wiper/washer

## Attachment

Boom oil-recirculation  
Headlight on boom (right, Halogen)  
Liebherr central lubrication system, fully-automatic (except connecting link for bucket kinematics)  
Load valve for stick cylinder (on distributor)  
Safety check valves on hoist cylinders  
Stick oil-recirculation

Non-exhaustive list, please contact us for further information.

\* optionally extendable after one year

# Options

## Undercarriage

- Chain kit, reinforced (D7G)
- Cover and base protection plates
- Special painting
- Steps, wide version
- Storage box
- Track guides (three pieces per track frame)
- Track pads, angled or chamfered

## Uppercarriage

- Additional headlights on uppercarriage (Halogen or LED) with protection
- Additional right-hand rearview mirror
- Bottom and lateral protection for uppercarriage
- Camera for side area monitoring
- Diesel refuelling pump (electric)
- Electric socket for external start-up aid (24 V)
- Electric socket for urea filling station (24 V)
- Fan drive, reversible
- Fine filter protection grid for radiator
- Fuel anti-theft device
- Fuel tank cap lockable with padlock
- Heavy counterweight
- SkyView 360° camera
- Special painting
- Storage box with extended tool set 40 pieces (incl. toolbox)
- Walkway, foldable
- Wiggins quick-coupling for fuel

## Hydraulic System

- Hydraulic bypass fine filter
- Liebherr hydraulic oil, adapted for extreme climate conditions
- Liebherr hydraulic oil, biodegradable

## Engine

- Air pre-filter with dust trap
- Automatic engine shut-down on idle (adjustable)
- Engine compartment lighting
- Engine shut-down self-timer
- Liebherr particle filter
- Wiggins quick coupling for engine oil

## Operator's Cab

- Additional front and/or rear cab headlights (Halogen or LED)
- Adjustable intensity headlights (LED)
- Amber beacon
- Auxiliary heater (programmable)
- Electric cool box (12 V)
- Electronic immobilizer
- Emergency stop button in cab

## Operator's Cab

- Falling objects protection structure (FOPS)
- Fire extinguisher
- First-aid kit
- Follow me headlights
- Footrest
- Front guard protection structure (FGPS)
- Front headlights (two pieces, LED)
- Handrest for joysticks
- Impact-resistant front window (one piece, non removable)
- Impact-resistant roof window
- Integral protection guard
- Liebherr proportional control (mini-joysticks 2 axis)
- Lower part windshield wiper
- Operator seat "Comfort" with four-point harness
- Operator seat "Premium" with integrated ventilation
- Radio "Comfort"
- Roof window wiper
- Special painting
- Sun visor
- Sunshield on cab roof
- Switchable high-pressure control
- Travel alarm

## Attachment

- Additional headlight on boom (left, Halogen or LED)
- Automatic lubrication system for connecting link
- Bottom protection for stick
- Eyelet on stick
- Filter for hydraulic hammer return flow
- Headlight on boom (right, LED)
- Headlights protection
- High pressure circuit
- Hoist cylinder stroke limitation, adjustable
- Hoist cylinders float position
- Hydraulic circuit for grapple
- Hydraulic or mechanical quick coupler
- Liebherr bucket range
- Liebherr tooth system
- LIKUFIX (quick-coupling system for hydraulic tools)
- Lubricant hoses protection on stick
- Middle pressure circuit
- Overload warning device
- Piston rod protection for adjustable cylinder
- Piston rod protection for bucket cylinder
- Piston rod protection for stick cylinder
- Preparation for automatic pedestrian detection system
- Preparation for machine guidance system
- Preparation for weighing system
- Protection for quick change-couplings, sideways on stick
- Safety check valves for stick cylinder
- Special painting
- Stick cylinder stroke limitation, adjustable
- Tool Control, 10 tool adjustments selectable via display
- Tool Management, automatic tool recognition (in combination with LIKUFIX)

Non-exhaustive list, please contact us for further information.

**Options and/or special attachments, supplied by vendors other than Liebherr, are only to be installed with the knowledge and approval of Liebherr in order to retain warranty.**

# The Liebherr Group of Companies



## Wide Product Range

The Liebherr Group is one of the largest construction equipment manufacturers in the world. Liebherr's high-value products and services enjoy a high reputation in many other fields. The wide range includes domestic appliances, aerospace and transportation systems, machine tools and maritime cranes.

## Exceptional Customer Benefit

Every product line provides a complete range of models in many different versions. With both their technical excellence and acknowledged quality, Liebherr products offer a maximum of customer benefits in practical application.

## State-of-the-art Technology

To provide consistent, top quality products, Liebherr attaches great importance to each product area, its components and core technologies. Important modules and components are developed and manufactured in-house, for instance the entire drive and control technology for construction equipment and mining trucks.

## Worldwide and Independent

Hans Liebherr founded the Liebherr family company in 1949. Since that time, the enterprise has steadily grown to a group of more than 130 companies with over 41,000 employees located on all continents. The corporate headquarters of the Group is Liebherr-International AG in Bulle, Switzerland. The Liebherr family is the sole owner of the company.

[www.liebherr.us](http://www.liebherr.us)