



8660

SERIES II

60-ton Hydraulic Truck Crane 50-mt Hydraulic Truck Crane

- 35.5'–110' (10.82–33.53 m) 4-section full power boom
- 28.5'–51' (8.69–15.54 m) two-piece offsettable fly, bi-fold, on-board lattice attachment with 2°, 20°, and 40° offsets—optional
- 167' (50.90 m) maximum tip height
- Modular style counterweights
- 15,871 lbs (70.59 kn) maximum winch line pull
- 502 fpm (153.2 m/min) maximum winch line speed
- Automated transmission
- 60.7 mph (97.7 km/hr) travel speed
- Front & rear air ride suspension
- Three lockable storage boxes
- "Stow 'n Go" steel pontoons



HTC 8660

SERIES II

This lean and mean machine is built to meet the toughest road laws.

- Drives like an automatic and has the power of a manual transmission
- Air ride suspension on front and rear axle
- Travels with full counterweight



Cruise in one load to your next job site!

- Speeds up to 60.7 mph (97.7 km/hr) on the highway, unmatched in the industry today
- Move it on the job site at 1.3 mph (2.0 km/hr) creep speed at idle for maximum maneuverability.
- Automated transmission (no clutch pedal) - 12 speeds forward, 2-speeds reverse with two modes of operation: fully automatic and semi-automatic
- Cruise control
- Three-stage engine compression brake
- Ether injection system - optional



Comfortable carrier cab provides high visibility

- Ultra-Cab with fiberglass construction
- Dash-mounted comprehensive instrumentation with backlit gauges
- Roll up/down door window provides excellent ventilation
- Fully adjustable air ride fabric seat
- Suspended pedals
- Right sideview and backup cameras



Hydraulic counterweight transfer/removal system

- Easily positions counterweight on carrier deck for efficient axle load distribution.
- **Modular counterweights** offer up to four lifting combinations.



There are three standard locking storage boxes with an optional fourth.



- Counterweight transfer removal controls located on each side of the upper structure.
- Innovative two-part paint coating technology, coupled with a pre-assembly paint process, provides the finest quality coating system available today.



Air-ride suspension front and rear provides a smooth ride and precise handling. Optional air-ride lift system holds the rear suspension retracted while the crane is on outriggers.

4-section full power boom with attachment flexibility

- 35.5' to 110' (10.8 - 33.5 m)
- 167' (50.90 m) maximum tip height with full attachment



Hammerhead boom nose allows the operator to work at high boom angles without fouling wire rope.



- Lightweight nylon head sheaves reduce weight and increase capacity.
- Quick reeve head machinery for fast, easy line change
- Optional auxiliary lifting sheave requires only one person to install and does not need to be removed when the attachment is erected, regardless of offset.

Optional 28.5' to 51' (8.7 - 15.5m) two-piece bi-fold lattice fly

- Erection of two-piece (bi-fold) lattice fly is a one-person operation — easy to erect & stow
- Exclusive design reduces side deflection when lifting load
- Also available: One-piece 28.5' (8.7 m) lattice fly with lugs to allow addition of second section
- Attachments offset to 2°, 20° and 40°



Side view camera



Exclusive **Amax mode** (mode "A") offers substantially increased capacities. **Standard mode** (mode "B") self-proportions all four sections equally.



Large engine doors allow for easy access

Non-slip surface strips on carrier deck

Large west coast-style rear viewing mirrors

Daytime running lights

Self-storing fifth outrigger pontoon

Overhead console for document storage with AM/FM radio

Aluminum wheels and radial tires with chrome and stainless wheel accents

Integrated air conditioning (not a roof-mounted system)

Powerful & responsive piston winch

- Two-speed motor with automatic brake
- Grooved drums minimize rope harmonic motion and improve spooling
- Optional auxiliary two-speed winch

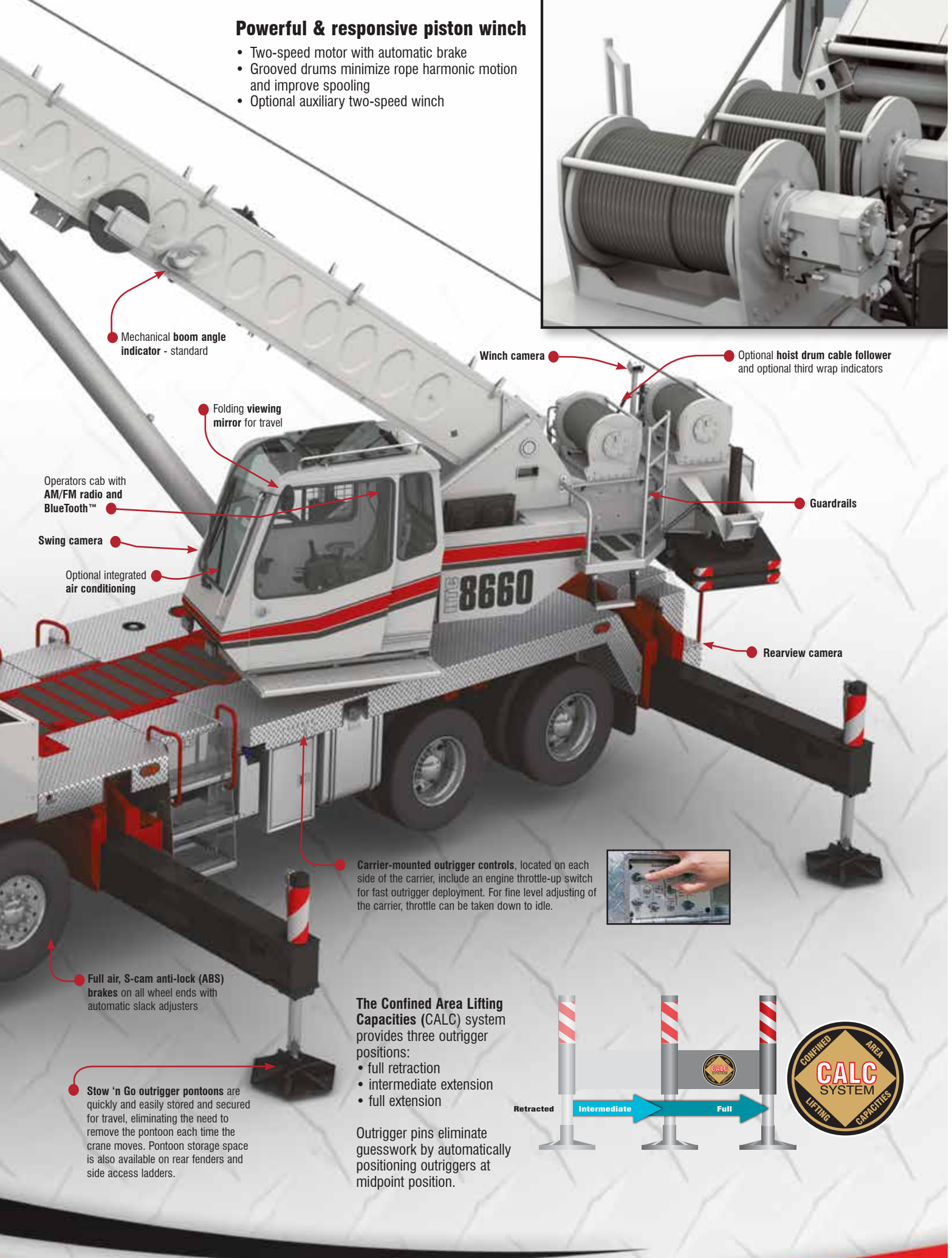

Mechanical boom angle indicator - standard

Winch camera

Optional hoist drum cable follower and optional third wrap indicators

Folding viewing mirror for travel

Guardrails

Operators cab with AM/FM radio and BlueTooth™

Swing camera

Optional integrated air conditioning

Rearview camera

Carrier-mounted outrigger controls, located on each side of the carrier, include an engine throttle-up switch for fast outrigger deployment. For fine level adjusting of the carrier, throttle can be taken down to idle.



Full air, S-cam anti-lock (ABS) brakes on all wheel ends with automatic slack adjusters

The Confined Area Lifting Capacities (CALC) system provides three outrigger positions:

- full retraction
- intermediate extension
- full extension

Stow 'n Go outrigger pontoons are quickly and easily stored and secured for travel, eliminating the need to remove the pontoon each time the crane moves. Pontoon storage space is also available on rear fenders and side access ladders.



Outrigger pins eliminate guesswork by automatically positioning outriggers at midpoint position.



The operator's cab is roomier and quieter than traditional cabs

- Six-way adjustable fabric seat with lift-up armrest (which deactivates control functions when raised)
- Armrest mounted, responsive **dual axis hydraulic controllers**
- Bubble level **sight level** mounted on side console
- **Ducted air** through automotive-style directional vents
- **Sliding right side**, rear windows and swing-up roof window
- **Single foot pedal** boom telescope control
- **Automotive-style windshield**
- Corner-post-mounted, **backlit gauges**
- Large, sweeping **electric wipers**
- **Dashless** design
- Engine-dependant warm water heating with defroster
- Winch and right side swing view cameras
- AM/FM radio



Superior accessibility

Access to the operator's cab and engine compartment is superb with strategically located ladders and steps. The pull-out CabWalk™ slides out from its secured travel position underneath the operator's cab to give the operator a platform to stand on for easy entry and exit from the cab.

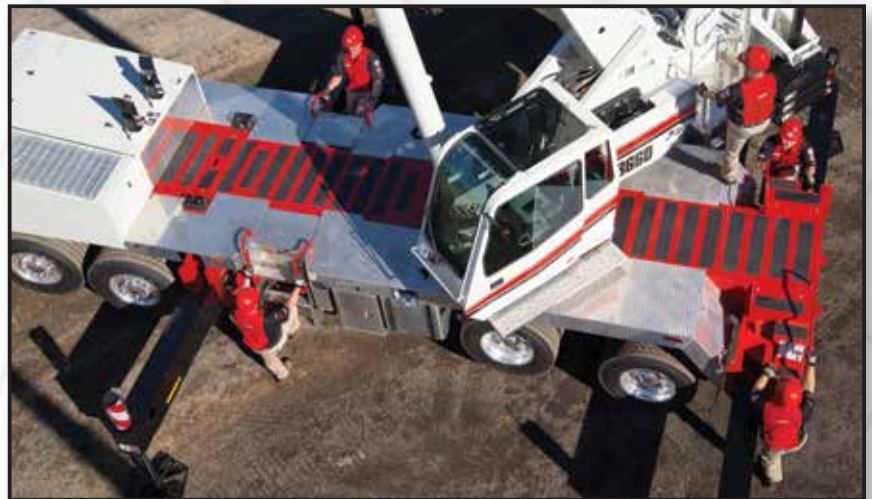

Link-Belt® PULSE



Optional external light bar



Internal light bar



Telematics. You own the data!

Cellular-based data logging and monitoring system that provides:

- Viewing options for sharing data with distributor and Link-Belt
- Location and operational settings
- Monitor routine maintenance intervals
- Crane and engine monitoring
- Diagnostic and fault codes



Link-Belt Construction Equipment Company is a leader in the design, manufacture and sales of telescopic and lattice boom cranes with headquarters and manufacturing facilities in Lexington, Kentucky, USA. Link-Belt is committed to the manufacture and service of high quality products that satisfy customers worldwide

Towards that end, Link-Belt has pursued a strategy of growth and investment. It has moved aggressively to seize more global market share by producing a broader range of products and strengthening distribution and personnel around the globe.

Link-Belt is also home to a family of passionate professionals with a legacy of innovation and cutting-edge technology spanning over 140 years. These professionals, in a 740,000 sq. ft. (68 748 m2) manufacturing facility and with a culture of continuous innovation, have pushed Link-Belt to be the most modern crane manufacturer in North America.

**Your crane investment is always protected...
with your Link-Belt distributor.**

When you invest in a Link-Belt crane, you invest in a legacy of outstanding customer support dating back to 1874. The ultimate value of a machine begins with state-of-the-art design and quality manufacturing, but it is the excellent Link-Belt distributor product support that determines its long term value. This philosophy has earned Link-Belt cranes the enviable position of traditionally commanding some of the highest resale prices in the industry.

... to be
recognized
as a
leader
in
**customer
service &
satisfaction.**
— The Link-Belt Vision

Link-Belt
Preferred

As a member of Link-Belt Cranes user's group, you will have access to:

- A comprehensive online library of parts, service & operator manuals for **YOUR** crane
- Interactive, live groundbearing calculations for **YOUR** crane
- Plus a vast array of information on new products, services and special offerings
- Online access to recommended spare parts lists, filter, lube and key lists plus maintenance information and more
- No annual fee or charges to access your crane information

**Online
3D LIFT
PLANNING**

- Web-based, active 3D, high graphic
- User-friendly, no CAD program required
- Always current, no updates required
- Print actual lift



**Online
GROUNDBEARING
PRESSURES**

- Dynamic specific machine model pontoon loadings
- Graphically illustrated in 360° numerical presentation
- Print out

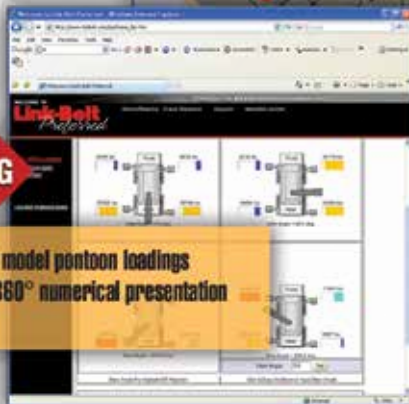

**Link-Belt
was born
because our
founding father
understood the
importance of
replacement parts.**

William Banta Everett

Building on that principal...

- Trained technical specialists
- Faster and more efficient customer service
- State of the art computer information systems
- 24 hours a day, 7 days a week
- 72,000 Sq. Ft. Parts Distribution Center
- All parts in stock ship the same business day

Link-Belt
CRANES
GENUINE
PARTS



©Link-Belt is a registered trademark. Copyright 2015
All rights reserved. We reserve the right to change
designs and specifications at any time.
Litho in U.S.A. 11/15 #4481 (supersedes #4420)

Link-Belt
CRANES
Lexington, Kentucky | www.linkbelt.com

Technical Data

Specifications & Capacities

HTC 8660

Series II
Telescopic Boom Truck Crane
60 US ton
50 metric ton

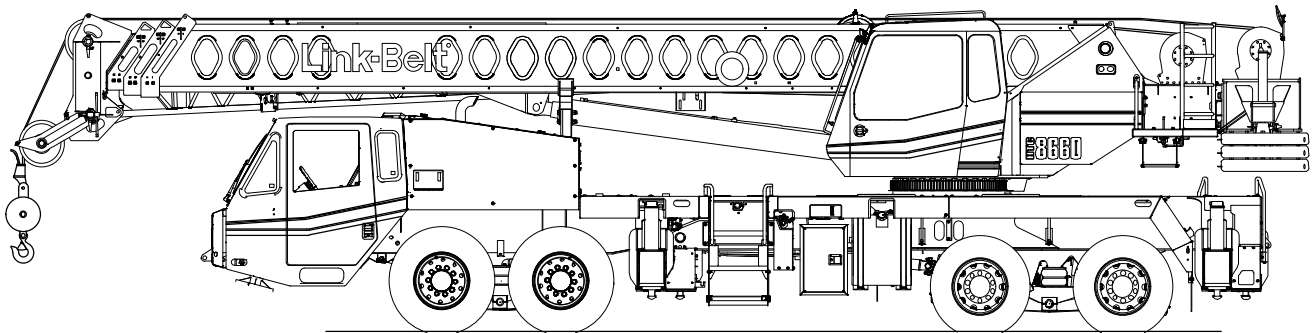

CAUTION: This material is supplied for reference use only. Operator must refer to in-cab Crane Rating Manual and Operator's Manual to determine allowable crane lifting capacities and assembly and operating procedures.

Table Of Contents

Boom, Attachments, and Upper Structure	1
Boom	1
Boom Head	1
Boom Elevation	1
Auxiliary Lifting Sheave – Optional	1
Hook Blocks and Balls – Optional	1
Fly – Optional	1
Upper Operator’s Cab and Controls	1
Swing	2
Electrical	2
Load Hoist System	3
Load Hoist Performance	3
2M Main and Optional Auxiliary Winches	3
Hydraulic System	3
Counterweight	3
Carrier	4
General	4
Outriggers	4
Steering and Axles	4
Suspension	4
Tires and Wheels	4
Brakes	4
Electrical	4
Engine	4
Transmission	5
Carrier Speeds and Gradeability	5
Fuel Tank	5
Hydraulic System	5
Pump Drive	5
Lower Cab and Controls	6
Additional Equipment	6
Axle Loads	7
Axle Loads with 2–Axle Boom Dolly	8
General Dimensions	9
EPA 2013	9
Tier 3 / Stage IIIA	10
Working Range Diagram	11

Boom Extend Modes	12
Main Boom Lift Capacity Charts — Standard	13
11,500 lb Counterweight — Fully Extended Outriggers — 360° Rotation	13
11,500 lb Counterweight — On Tires — Stationary — Boom Centered Over Rear	14
11,500 lb Counterweight — On Tires — Pick & Carry (1 mph) — Boom Centered Over Rear	14
Main Boom Lift Capacity Charts — Optional	15
15,100 lb Counterweight — Fully Extended Outriggers — 360° Rotation	15
15,100 lb Counterweight — On Tires — Stationary — Boom Centered Over Rear	16
15,100 lb Counterweight — On Tires — Pick & Carry (1 mph) — Boom Centered Over Rear	16
Fly Attachment Lift Capacity Charts — Optional	17
11,500 lb Counterweight — Fully Extended Outriggers — 360° Rotation	17
110 ft Main Boom Length 2° Fly Offset	17
110 ft Main Boom Length 20° Fly Offset	17
110 ft Main Boom Length 40° Fly Offset	17
15,100 lb Counterweight — Fully Extended Outriggers — 360° Rotation	18
110 ft Main Boom Length 2° Fly Offset	18
110 ft Main Boom Length 20° Fly Offset	18
110 ft Main Boom Length 40° Fly Offset	18
Main Boom Lift Capacity Charts — Optional (Metric)	19
5.2t Counterweight — Fully Extended Outriggers — 360° Rotation	19
5.2t Counterweight — On Tires — Stationary — Boom Centered Over Rear	20
5.2t Counterweight — On Tires — Pick & Carry (1.6km/h) — Boom Centered Over Rear	20
6.8t Counterweight — Fully Extended Outriggers — 360° Rotation	21
6.8t Counterweight — On Tires — Stationary — Boom Centered Over Rear	22
6.8t Counterweight — On Tires — Pick & Carry (1.6km/h) — Boom Centered Over Rear	22
Fly Attachment Lift Capacity Charts — Optional (Metric)	23
5.2t Counterweight — Fully Extended Outriggers — 360° Rotation	23
33.53m Main Boom Length 2° Fly Offset	23
33.53m Main Boom Length 20° Fly Offset	23
33.53m Main Boom Length 40° Fly Offset	23
6.8t Counterweight — Fully Extended Outriggers — 360° Rotation	24
33.53m Main Boom Length 2° Fly Offset	24
33.53m Main Boom Length 20° Fly Offset	24
33.53m Main Boom Length 40° Fly Offset	24

Boom, Attachments, and Upper Structure

■ Boom

Design — Four section, box type construction of high tensile steel consisting of one base section and three telescoping sections. The vertical side plates have diamond shaped impression for superior strength to weight ratio. The first telescoping section extends independently by means of one double-acting, single stage hydraulic cylinder with integrated holding valves. The second and third telescoping sections extend proportionally by means of one double-acting, single stage cylinder with integrated holding valves and cables.

Boom

- 35.5–110 ft (10.8–33.5m) four-section full power boom
- Two mode boom extension: A—max mode provides superior capacities by extending the first telescope section to 60.3 ft (18.4m). Standard mode synchronizes all the telescoping sections proportionally to 110 ft (33.5m). Controlled from operator's cab.
- Mechanical boom angle indicator
- Maximum tip height for A—max mode is 68.8 ft (21.0m) and standard mode is 117.4 ft (35.8m).

Boom Head

- Four 16.5 in (41.9cm) root diameter nylon sheaves to handle up to eight parts of line
- Easily removable wire rope guards
- Rope dead end lugs on each side of the boom head
- Boom head is designed for quick-reeve of the hook block

Boom Elevation

- One double acting hydraulic cylinder with integral holding valve
- Boom elevation: -3° to 78°

Auxiliary Lifting Sheave — Optional

- Single 16.5 in (41.9m) root diameter nylon sheave
- Easily removable wire rope guards
- Does not affect erection of the fly or use of the main head sheaves

Hook Blocks and Balls — Optional

- 25 ton (22.7mt) 3 sheave quick-reeve hook block with safety latch
- 40 ton (36.3mt) 4 sheave quick-reeve hook block with safety latch
- 50 ton (45.4mt) 5 sheave quick-reeve hook block with safety latch
- 8.5 ton (7.7mt) swivel and non-swivel hook balls with safety latch
- 60 ton (54.4mt) 5 sheave quick-reeve hook block with safety latch
- 45 ton (40.8mt) 3 sheave quick-reeve hook block with safety latch

Fly — Optional

- 28.5 ft (8.7m) one piece lattice fly, stowable, offsettable to 2° , 20° , and 40° . Maximum tip height is 144.8 ft (44.1m).
- 28.5–51 ft (8.7–15.5m) two piece bi-fold lattice fly, stowable, offsettable to 2° , 20° and 40° . Maximum tip height is 166.9 ft (50.9m).

■ Upper Operator's Cab and Controls

Environmental Cab — Fully enclosed, one person cab of galvalneal steel structure with acoustical insulation. Equipped with:

- Tinted and tempered glass windows
- Extra-large fixed front window with windshield wiper and washer
- Swing up roof window with windshield wiper and washer
- Sliding left side door with large fixed window
- Sliding rear and right side windows for ventilation
- Six way adjustable, cushioned seat with seat belt and storage compartment
- Diesel fired warm-water heater with air ducts for front windshield defroster and cab floor
- Defroster fan for the front window
- Bubble level
- Circulating fan
- Adjustable sun visor
- LED Dome light
- Cup holder
- Fire extinguisher
- Left side viewing mirror
- Pull-out cabwalk
- Two position travel swing lock
- AM/FM Radio

Air Conditioning — Optional — Integral with cab heating system utilizing the same ventilation outlets

Armrest Controls — Two dual axis hydraulic joystick controllers or optional single axis hydraulic controllers for:

- Swing
- Boom hoist
- Main rear winch
- Auxiliary front winch — optional
- Drum rotation indication
- Drum rotation indicator activation switch
- Swing park brake switch
- Winch high/low speed and disable switch(es)
- Telescope override switch
- Warning horn button
- Pump enable
- Heating controls
- Air conditioning — optional
- Engine throttle block

Outrigger Controls — Hand held control box with umbilical cord gives the operator the freedom to view operation while setting the outriggers.

Foot Controls

- Boom telescope
- Swing brake
- Engine throttle

Right Front Console – Controls and indicators for:

- Engine ignition
- Function disable
- Front windshield wiper and washer
- Cab floodlights
- Warning horn
- Console dimmer switch
- Bubble level
- 12 volt power connection
- Boom floodlight – optional
- Rotating beacon or strobe light switch – optional
- Third wrap selector switch – optional

Camera Display – Located on dash console

- Displays right side of upper
- Displays main and auxiliary winches

Cab Instrumentation – Ergonomically positioned LCD display, CANBUS instrumentation for crane operation including:

- Tachometer
- Engine water temperature
- Fuel level
- Hydraulic oil temperature
- Stop engine
- Check engine
- Diesel exhaust fluid
- Regeneration disabled light (EPA 2013 engine only)
- DPF regeneration light (EPA 2013 engine only)
- High exhaust temperature light (EPA 2013 engine only)
- Malfunction indicator lamp (EPA 2013 engine only)
- Engine oil pressure
- Swing park brake light
- Battery voltage
- Fuel rate (gal/hr)
- Engine load
- Engine Diagnostics
- Third wrap indicator

Link-Belt Pulse – The Link-Belt in-house designed, total crane operating system that utilizes the display as a readout and operator interface for the following systems:

- **Rated capacity limiter** – LCD graphic audio – visual warning system integrated into the dash with anti – two block and function limiter. Operating data includes:
 - Crane configuration
 - Boom length and angle
 - Boom head height
 - Allowed load and % of allowed load
 - RCL light bar
 - Boom angle
 - Radius of load
 - Actual load
 - Wind speed
 - Highlighted unit of measurement on working screen
 - Telescope operation displayed in real time
 - Diagnostics
 - Operator settable alarms (include):
 - Maximum and minimum boom angles
 - Maximum tip height
 - Maximum boom length
 - Swing left/right positions
 - Operator defined area (imaginary plane)
- **Telematics** – Cellular–based data logging and monitoring system that provides:
 - Location and operational settings
 - Routine maintenance
 - Crane and engine monitoring
 - Diagnostic and fault codes

Integrated Third Wrap Indicator – Optional – Link–Belt Pulse color display visually and audibly warns the operator when the wire rope is on the first/bottom layer and when the wire rope is down to the last three wraps.

Integrated Third Wrap Function Kickout – Optional – Link–Belt Pulse color display visually and audibly warns the operator when the wire rope is on the first/bottom layer and provides a function kickout when the wire rope is down to the last three wraps.

Internal RCL Light Bar – Visually informs the operator when crane is approaching maximum load capacity with a series of green, yellow, and red lights.

External RCL Light Bar – Optional – Visually informs the ground crew when crane is approaching maximum load capacity with a series of green, yellow, and red lights.

■ Swing

Motor/Planetary – Bi–directional hydraulic swing motor mounted to a planetary reducer for 360° continuous smooth swing at 2.5 rpm.

Swing Park Brake – 360°, electric over hydraulic, (spring applied/hydraulic released) multi–disc brake mounted on the speed reducer. Operated by a switch from the operator’s cab.

Swing Brake – 360°, foot operated, hydraulic applied disc brake mounted to the speed reducer.

Swing Lock – Two–position swing lock (boom over front or rear) operated from the operator’s cab.

360° Positive Swing Lock – Optional – Meets New York City requirement.

■ Electrical

Swing Alarm – Audio warning device signals when the upper is swinging.

Lights

- Two LED working lights on front of the cab
- One LED working light on the top of the cab – optional
- One amber strobe beacon on top of the cab – optional
- Boom floodlight – Single – optional
- Boom floodlight – Dual – optional
- Boom floodlight – High intensity remote controlled – optional

Load Hoist System

Load Hoist Performance

Main (Rear) and Auxiliary (Front) Winches — 5/8 in (16mm) Rope										
Layer	Maximum Line Pull		Normal Line Speed		High Line Speed		Layer		Total	
	lb	kN	ft/min	m/min	ft/min	m/min	ft	m	ft	m
1	15,871	70.59	166	50.5	329	100.2	97	29.6	97	29.6
2	14,356	63.86	183	55.8	364	110.8	108	32.6	205	62.5
3	13,104	58.29	201	61.2	398	121.4	117	36.0	322	98.1
4	12,054	53.62	218	66.5	433	132.0	128	39.0	450	137.2
5	11,159	49.64	236	71.8	468	142.6	139	42.1	589	179.5
6	10,388	46.21	253	77.2	502	153.2	148	45.1	737	224.6

Wire Rope Application		Diameter		Type	Maximum Permissible Load	
		in	mm		lb	kg
Main (Rear) Winch	Standard	5/8	16	18x19 rotation resistant — right regular lay (Type RB)	9,080	4 118.6
	Optional	5/8	16	34x7 rotation resistant — right regular lay (Type ZB)	11,080	5 030
Auxiliary (Front) Winch	Standard	5/8	16	18x19 rotation resistant — right regular lay (Type RB)	9,080	4 118.6
	Optional	5/8	16	34x7 rotation resistant — right regular lay (Type ZB)	11,080	5 030

2M Main and Optional Auxiliary Winches

- Axial piston, full and half displacement (2—speed) motors driven through planetary reduction unit for positive control under all load conditions.
- Grooved lagging
- Power up/down mode of operation
- Hoist drum cable follower — optional
- Drum rotation indicator
- Drum diameter: 10.63 in (27.0cm)
- Rope length:
 - Main: 550 ft (167.6m)
 - Auxiliary: 450 ft (137.2m) or 550 ft (167.6m)
- Terminator style socket and wedge

Hydraulic System

Counterbalance Valves — All hoist motors, boom extend cylinders, and boom hoist cylinder are equipped with counterbalance valves to provide load lowering and to prevent accidental load drop if hydraulic power is suddenly reduced.

Hydraulic Oil Cooler — Carrier mounted cooler removes heat from the hydraulic oil. Cooler is integral to the engine radiator/charge air cooler.

Boom Hoist Float Valves (Optional) — For transporting the boom over the rear of the crane with a boom dolly. Allows hydraulic oil within the boom hoist cylinder to flow between piston side and rod side, allowing the boom to float while on the boom dolly.

Swing Brake Release — For transporting the boom over the rear of the crane with a boom dolly. Holds the 360° swing park brake in the released position allowing free rotation of the upper structure.

Counterweight

Standard — 11,500 lb (5.2t) total counterweight consisting of two, hydraulically removable 3,600 lb (1.6t) counterweights with capacities for 4,300 lb (2.0t) and 7,900 lb (3.6t) counterweight configurations. Assembled and disassembled by hydraulic cylinders controlled from both sides of the upper structure.

Optional — 3,600 lb (1.6t) in addition to standard counterweight for a total of 15,100 lb (6.8t).

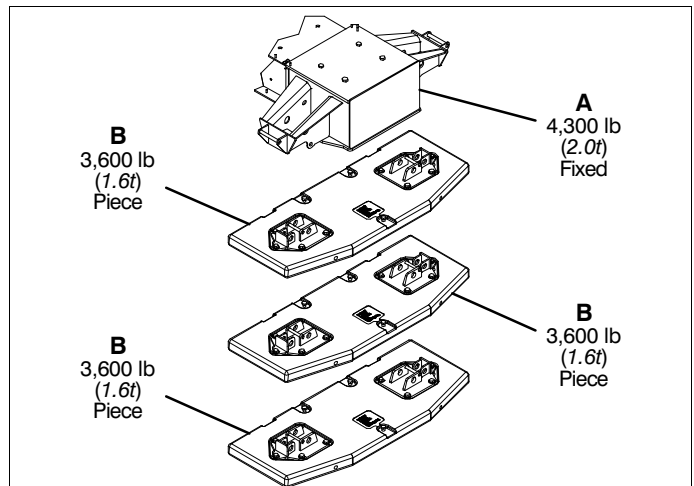

Counterweight Packages		11,500 lb (5.2t) — Standard			
		15,100 lb (6.8t) — Optional			
Counterweight Pieces		A	B	B	B
		4,300 lb (2t) Fixed	3,600 lb (1.6t) Piece	3,600 lb (1.6t) Piece	3,600 lb (1.6t) Piece
A	4,300 lb (2t)	X			
A,B	7,900 lb (3.6t)	X	X		
A,B,B	11,500 lb (5.2t)	X	X	X	
A,B,B,B	15,100 lb (6.8t)	X	X	X	X

Carrier

General

- 8 ft 6 in (2.6 m) wide
- 23 ft 10 in (7.26m) wheelbase (centerline of first axle to centerline of fourth axle)
- **Frame** — Box-type, torsion resistant, welded construction made of high tensile steel. Equipped with front and rear towing and tie-down lugs, tow connections, and access ladders.

Outriggers

Boxes — Two double box, front and rear welded to the carrier frame.

Beams and Jacks — Four single stage beams with Confined Area Lifting Capacities (CALC) provide selectable outrigger extensions of full, intermediate, and retracted positions. Jacks with integral check valve, hydraulically controlled from the operator's cab and on both sides of carrier. A fifth front bumper outrigger with integral check valve is hydraulically controlled from the operator's cab and at the front bumper of carrier.

Pontoons

- **Main** — Four lightweight, stow'n go, 23.5" x 27.25" (59.7 x 69.2cm) hexagonal steel pontoons with a contact area of 485 in² (3 129cm²) can be stored for road travel in either the storage racks on the carrier or under the outrigger boxes
- **Front Bumper** — One, lightweight, self-storing, 16" (40.6cm) diameter steel pontoon with a contact area of 201 in² (1 296cm²)

Jack Reaction

- **Main** — 76,000 lb (338.1kN) force and 157 psi (1 082.5kPa) ground bearing pressure
- **Front Bumper** — 37,000 lb (164.6kN) force and 184 psi (21 269kPa) ground bearing pressure

Steering and Axles

- Sheppard full integral master gear/slave gear steering system provides hydraulic assisted steering with mechanical link between steering wheel and wheels
- **Drive** — 8 x 4 for on/off-highway travel
- **Axle 1 & 2** — Tandem steered, non-driven
- **Axle 3 & 4** — Tandem non-steered, driven with reduction: 5.38 to 1
- **Inter-Axle Differential Lock** — Traction adding device that locks axle 3 with axle 4. Operated by a switch from the carrier cab.

Suspension

Front — Raydan Air Link walking beam air suspension

Rear — Raydan Air Link walking beam air suspension

- **Axle Lift System — Optional** — Improves rear tire ground clearance when the crane is up on outriggers. The rear air suspension can be raised or lowered with a switch in the carrier cab. The axle lift system can be controlled with a switch on both sides of the carrier.

Tires and Wheels

Front — Four (single) 425/65R22.5 tires on aluminum disc wheels

Rear — Eight (dual) 11R22.5 tires on aluminum outer/steel inner disc wheels

- Spare tires and wheels — optional

- Tire inflation kit — optional

Brakes

Service — Full air anti-lock (ABS) brakes on all wheel ends. Dual circuit compressed air system with air dryer.

Parking/Emergency — Spring loaded type, acting on 3rd and 4th axles automatically apply when air pressure drops below 40 psi (275.8kPa) in both circuits.

Electrical

Battery — Three batteries provide 12 volt starting and operation

Lights

- Front lighting includes two main daytime running/headlights, two high beam lights, two parking/directional indicators, and three cab marker lights.
- Side lighting includes three parking/directional indicators per side.
- Rear lighting includes two parking/directional indicators, two parking/brake lights, two reverse lights, three marker lights, and a license plate light.
- Other equipment includes hazard/warning system, two cab LED dome lights, instrument panel back lighting, and signal horn.
- One amber strobe beacon behind the cab.

Engine

Specification	Cummins ISL9	Cummins QSM
Emissions Compliance Level:	EPA 2013 (1)	Tier 3/Stage IIIA(2)
Maximum Allowable Sulfur Content of Fuel (PPM):	15	5000
Numbers of cylinders:	6	6
Cycle:	4	4
Bore and Stroke: inch (mm)	4.49 x 5.69 (114x144)	4.9 x 5.8 (125x147)
Piston Displacement: in ³ (L)	543 (8.9)	660 (10.8)
Max. Brake Horsepower: hp (kW)	370 (276) @ 1,700 rpm 365 (272) @ 2,100 rpm	400 (298) @ 1,800 rpm 375 (280) @ 2,100 rpm
Peak Torque: ft lb (Nm)	1,250 (1 694.7) @ 1,400 rpm	1,400 (1 898) @ 1,300 rpm
Alternator: volts — amps	12 — 145	12 — 160
Crankcase Capacity: qt (L)	26 (24.6)	40 (38)

- Cruise control
- Cummins ISL — Three stage compression brake
- Cummins QSM — Two stage compression brake
- Thermostatically controlled, hydraulically driven radiator fan
- 120 volt engine block heater
- Ether injection system — optional (QSM only)
- Grid heater starting aid standard on ISL9
- Engine equipped with on-board diagnostics — ISL

(1) Can only be sold and/or operated where EPA2013 on-highway emission standards are accepted.

(2) Can only be sold and/or operated where Tier 3/Stage IIIA off-highway emission standards are accepted.

■ Transmission

Automated – ZF AS–TRONIC (no clutch pedal) manual transmission with 12 forward gears and 2 reverse gears.

■ Carrier Speeds and Gradeability

ZF Astronic		Governed Speed				Gradeability (@ Peak Torque Except Creep @ Idle)		
		EPA 2013		Tier 3/Stage IIIA		% Grade		
Gear	Ratio	mph	km/h	mph	km/h	EPA 2013	Tier 3/ Stage IIIA	
						12th	0.78	60.69
11th	1.00	47.22	75.97	47.03	75.68	2.35	3.92	
10th	1.27	37.27	59.96	37.12	59.73	2.98	5.34	
9th	1.63	28.99	46.64	28.87	46.46	3.83	7.19	
8th	2.10	22.47	36.16	22.38	36.01	4.94	9.56	
7th	2.70	17.49	28.14	17.42	28.03	6.35	12.54	
6th	3.55	13.29	21.39	13.24	21.30	8.35	16.74	
5th	4.57	10.34	16.64	10.30	16.57	10.73	21.72	
4th	5.78	8.16	13.14	8.13	13.08	13.59	27.71	
3rd	7.44	6.35	10.22	6.33	10.18	17.47	35.81	
2nd	9.59	4.92	7.92	4.90	7.88	22.54	43.10	
1st	12.33	3.83	6.16	3.82	6.14	28.97	43.10	
Reverse 1		11.41	4.14	6.66	4.12	6.63	26.82	43.10
Reverse 2		8.88	5.32	8.56	5.30	8.52	20.87	42.90
Creep @ idle	2nd	9.59	1.64	2.64	1.63	2.62	26.68	22.05
	1st	12.33	1.27	2.04	1.27	2.04	34.29	28.52
	Reverse 1	11.41	1.38	2.22	1.37	2.20	31.75	26.36
	Reverse 2	8.88	1.77	2.85	1.77	2.84	24.70	20.37

Based on a gross vehicle weight of 78,000 lb (35 380kg)

■ Fuel Tank

- One 75 gal (283.9L) capacity tank
- One 10 gal (37.8L) capacity diesel exhaust fluid (DEF) plastic tank

■ Hydraulic System

All functions are hydraulically powered allowing positive, precise control with independent or simultaneous operation of all functions.

Main Pumps

- Four fixed displacement gear pumps with automatic disconnect for the main and auxiliary winches, swing, boom hoist, control circuit, and telescope for use when crane is in travel mode
- One fixed displacement gear pump for steering and the front bumper outrigger
- Two fixed displacement gear pumps for engine cooling fan and main outriggers. These pumps also provide flow to the winches and boom hoist for “pick & carry” mode. Operated by a switch in the carrier cab.
- Combined pump capacity of 190 gpm (719.2Lpm)

Hydraulic Reservoir – 144 gal (545.1L) capacity equipped with sight level gauge. Diffusers built in for deaeration.

Filtration – One 10 micron, full flow, return line filter. All oil is filtered prior to return to reservoir. Accessible for easy filter replacement.

■ Pump Drive

All pumps are mechanically driven by the diesel engine. Main and auxiliary winches, swing, boom hoist, control circuit, and telescope pumps are mounted to an automatic pump disconnect on the rear of the transmission to aid in cold weather starting as well as to reduce pump wear while traveling.

■ Lower Cab and Controls

Environmental Cab — Fully enclosed, one person cab of composite structure with acoustical insulation. Equipped with:

- Tinted and tempered glass windows
- Roll down left side window for ventilation
- Right side window
- Windshield wiper and washer
- Six way adjustable and air suspended driver's seat with seat belt
- Two adjustable rear view mirrors
- Engine dependent warm—water heater with air ducts for windshield defroster and cab floor
- Adjustable sun visor
- Two LED dome lights
- 12 volt connection
- Fire extinguisher

Air Conditioning — Integral with cab heating system utilizing the same ventilation outlets

Overhead Console — Located above the sun visor

- Document storage unit
- AM/FM Radio
- 12 volt accessory jack (switched)
- 12 volt accessory jack (unswitched)
- Strobe beacon switch

Camera Display — Located on dash console

- Displays right side of machine
- Displays rear view

Cab Instrumentation — Ergonomically positioned analog instrumentation for driving including:

- Speedometer with odometer, hourmeter, trip odometer
- Front and rear air pressure with warning indicator
- Engine coolant temperature with warning indicator
- Engine oil pressure with warning indicator
- Voltage indicator with warning indicator
- Fuel level
- Tachometer
- Diesel exhaust fluid with warning indicator (EPA 2013 Engine Only)

Right Side Console — Controls and indicators for:

- Transmission gear shifting
- Transmission gear selector
- Transmission digital readout
- Cruise controls
- Engine compression brake controls

Dash Mounted Controls For:

- Carrier lights
- Carrier/upper throttle control
- Engine cooling fan override
- Cab heater/air conditioning
- Console dimmer switch
- Anti—lock brake diagnostic switch
- Diesel particulate filter switch (EPA 2013 Engine Only)
- Park brake
- Pick & carry switch
- Inter—axle differential lock switch
- Engine ignition
- Rear axle lift system switch — optional
- Diesel particulate filter regeneration inhibit switch (EPA 2013 Engine Only)

Dash Mounted Indicator For:

- Check, stop, and service engine
- Turn signal indication
- Park brake
- Cruise activation
- High beam headlights
- Check anti—lock brake system
- Check anti—lock trailer brake system
- Diesel particulate filter indication (EPA 2013 Engine Only)
- High exhaust temperature indication (EPA 2013 Engine Only)
- Regeneration inhibit (EPA 2013 Engine Only)
- Wait to start (EPA 2013 Engine Only)
- Malfunction indicator lamp (EPA 2013 Engine Only)
- Engine air filter high restriction

Steering Column Controls For:

- Warning horn
- Turn indicators
- High beam headlights
- Steering wheel adjustments
- Intermittent windshield wiper and washer
- Hazard lights

Foot Controls For:

- Carrier service brakes
- Engine throttle

■ Additional Equipment

Standard:

- Aluminum full deck fenders with mud flaps
- Left and right bubble levels
- Air hose connection ports
- Clearance flags

Optional:

- Pneumatic and electrical quick disconnect connectors mounted on the rear for trailer or boom dolly brakes and lights
- Left side aluminum storage box
- Rear mounted pintle hook

Axle Loads

Base crane with full tank of fuel and 4,300 lb (2.0t) counterweight	Gross Vehicle Weight ⁽¹⁾		Front Axles		Rear Axles	
	lb	kg	lb	kg	lb	kg
	EPA 2013	65,428	29 678	29,264	13 274	36,164
Tier 3/Stage IIIA	65,651	29 779	29,624	13 437	36,027	16 342
Driver in carrier cab	250	113	328	149	-78	-35
Rear pintle hook	34	15	-13	-6	47	21
Pneumatic and electrical connectors for trailer or boom dolly	11	5	-4	-2	15	7
Carrier aluminum storage box	66	30	20	9	46	21
Air ride lift system – rear axles	52	24	7	3	45	20
Ether injection	5	2	5	2	0	0
Hoist drum follower – main	75	34	-27	-13	102	47
Auxiliary winch with 450 ft (137.2m) of 5/8" (16mm) type "RB" rope	414	188	-98	-45	512	232
Hoist drum follower – auxiliary	75	34	-16	-8	91	42
Substitute 450 ft (137.2m) with 550 ft (167.6m) rope – auxiliary	72	33	-17	-8	89	40
Remove 550 ft (167.6m) of rope from rear (main) winch	-482	-219	183	83	-665	-302
Remove 450 ft (137.2m) of rope from front (auxiliary) winch	-396	-180	95	43	-491	-223
Air conditioner – operator's cab	179	81	3	1	176	80
360° mechanical swing lock	60	27	6	3	54	24
One slab of counterweight on upper	3,582	1 625	-1,375	-624	4,957	2 248
Two slabs of counterweight on upper	7,164	3 250	-2,750	-1 247	9,914	4 497
Three slabs counterweight on upper	10,746	4 874	-4,125	-1 871	14,871	6 745
Floodlight to the front of boom base section	10	5	15	7	-5	-2
Fly mounting brackets to boom base section for fly options	99	45	87	39	12	5
28.5 ft (8.7m) offsettable, one-piece lattice fly – stowed	1,238	562	1,312	595	-74	-34
28.5–51 ft (8.7–15.5m) offsettable, two-piece (bi-fold) lattice fly – stowed	1,830	830	1,810	821	20	9
Auxiliary lifting sheave	91	41	165	75	-74	-34
25 ton (22.7mt) 3-sheave hook block at boom head	670	304	1,169	530	-499	-226
40 ton (36.3mt) 4-sheave hook block at boom head	780	354	1,360	617	-580	-263
50 ton (45.4mt) 5-sheave hook block at boom head	1,090	494	1,901	862	-811	-368
60 ton (54.4mt) 5-sheave hook block at boom head	1,122	509	1,957	888	-835	-379
8.5 ton (7.7mt) hook ball at boom head	360	163	641	291	-281	-127
Hook block/ball storage box	375	170	-143	-65	518	235
25 ton (22.7mt) 3-sheave hook block in storage box	670	304	-256	-116	926	420
40 ton (36.3mt) 4-sheave hook block in storage box	780	354	-298	-135	1,078	489
50 ton (45.4mt) 5-sheave hook block in storage box	1,090	494	-417	-189	1,507	684
60 ton (54.4mt) 5-sheave hook block in storage box	1,122	509	-429	-195	1,551	704
8.5 ton (7.7mt) hook ball in storage box	360	163	-138	-63	498	226

Counterweight Load Transfer	Front Axles		Rear Axles	
	lb	kg	lb	kg
Transfer one 3,600lb (1.6t) slab of counterweight to carrier deck	4,091	1 856	-4,091	-1 856
Transfer two 3,600lb (1.6t) slabs of counterweight to carrier deck	8,182	3 711	-8,182	-3 711
Transfer three 3,600lb (1.6t) slabs of counterweight to carrier deck	12,273	5 567	-12,273	-5 567

Axle	Maximum Load @ 65 mph (105km/h)
Front	45,400 lb (20 593kg) – aluminum disc wheels with 425/65R22.5 tires
Rear	47,250 lb (21 432kg) – aluminum disc wheels with 11R22.5 tires

(1) Adjust gross vehicle weight and axle loading according to component weight. All weights are ±3%.

Axle Loads with 2–Axle Boom Dolly

Base crane with full tank of fuel and 4,300 lb (2.0t) counterweight	Gross Vehicle Weight ⁽¹⁾		Front Axles		Rear Axles		Dolly Axles	
	lb	kg	lb	kg	lb	kg	lb	kg
	EPA 2013	65,428	29 678	27,392	12 425	27,303	12 384	10,733
Tier 3/Stage IIIA	65,651	29 779	27,652	12 543	27,266	12 368	10,733	4 868
Nelson 2–axle boom dolly	6,000	2 722	0	0	0	0	6,000	2 722
Driver in carrier cab	250	113	328	149	-78	-35	0	0
Rear pintle hook	34	15	-13	-6	47	21	0	0
Pneumatic and electrical connectors for trailer or boom dolly	11	5	-4	-2	15	7	0	0
Carrier aluminum storage box	66	30	20	9	46	21	0	0
Air ride lift system – rear axles	52	24	7	3	45	20	0	0
Ether injection	5	2	5	2	0	0	0	0
Air conditioning – carrier	58	26	83	38	-25	-11	0	0
Hoist drum follower – main	75	34	55	25	21	10	0	0
Auxiliary winch with 450 ft (137.2m) of 5/8" (16mm) type "RB" rope	414	188	253	115	161	73	0	0
Hoist drum follower – auxiliary	75	34	44	20	32	14	0	0
Substitute 450 ft (137.2m) with 550 ft (167.6m) rope – auxiliary	72	33	44	20	28	13	0	0
Remove 550 ft (167.6m) of rope from rear (main) winch	-482	-219	-364	-165	-118	-54	0	0
Remove 450 ft (137.2m) of rope from front (auxiliary) winch	-396	-180	-243	-110	-153	-69	0	0
Air conditioner – operator's cab	179	81	64	29	115	52	0	0
360° mechanical swing lock	60	27	16	7	44	20	0	0
One slab of counterweight on upper	3,582	1 625	2,716	1 323	866	393	0	0
Two slabs of counterweight on upper	7,164	3 250	5,432	2 464	1,732	786	0	0
Three slabs counterweight on upper	10,746	4 874	8,148	3 696	2,598	1 178	0	0
Floodlight to the front of boom base section	10	5	-1	-0.5	-1	-0.5	12	5
Fly mounting brackets to boom base section for fly options	99	45	12	5	14	6	72	33
28.5 ft (8.7m) offsettable, one–piece lattice fly – stowed	1,238	562	80	36	89	40	1,069	485
28.5–51 ft (8.7–15.5m) offsettable, two–piece (bi–fold) lattice fly – stowed	1,830	830	163	74	182	83	1,484	673
Auxiliary lifting sheave	91	41	-18	-8	-20	-9	130	59
40 ton (36.3mt) 4–sheave hook block at boom head	780	354	-138	-63	-154	-70	1,072	486
50 ton (45.4mt) 5–sheave hook block at boom head	1,090	494	-193	-88	-215	-98	1,498	679
60 ton (54.4mt) 5–sheave hook block at boom head	1,122	509	-198	-90	-221	-100	1,542	699
8.5 ton (7.7mt) hook ball at boom head	360	163	-68	-31	-76	-34	504	229

Counterweight Load Transfer	Front Axles		Rear Axles		Dolly Axles	
	lb	kg	lb	kg	lb	kg
Transfer one 3,600lb (1.6t) slab of counterweight to boom dolly	-2,716	-1 232	-866	-393	3,582	1 625
Transfer two 3,600lb (1.6t) slabs of counterweight to boom dolly	-5,432	-2 464	-1,732	-786	7,164	3 250
Transfer three 3,600lb (1.6t) slabs of counterweight to boom dolly	-8,148	-3 696	-2,598	-1 178	10,746	4 874

Axle	Maximum Load @ 65 mph (105km/h)
Front	45,400 lb (20 593kg) – aluminum disc wheels with 425/65R22.5 tires
Rear	47,250 lb (21 432kg) – aluminum disc wheels with 11R22.5 tires

⁽¹⁾ Adjust gross vehicle weight and axle loading according to component weight. All weights are ±3%.

General Dimensions

■ EPA 2013

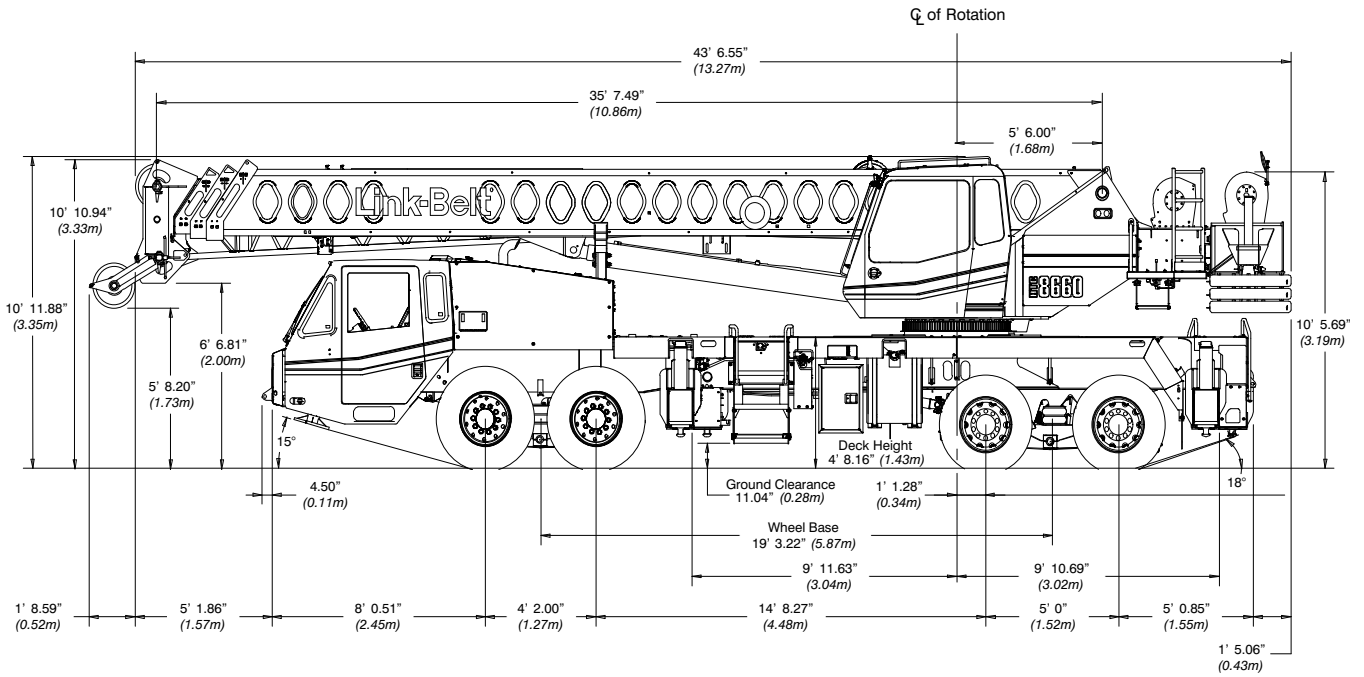

Turning Radius	English	Metric
Wall to wall over carrier	44' 1"	13.4m
Wall to wall over boom	45' 6"	13.9m
Wall to wall over boom attachment	46' 11"	14.3m
Centerline of tire	38' 7"	11.8m

Tail Swing	English	Metric
With counterweight	12' 8.5"	3.9m
Without counterweight	12' 5.25"	3.8m

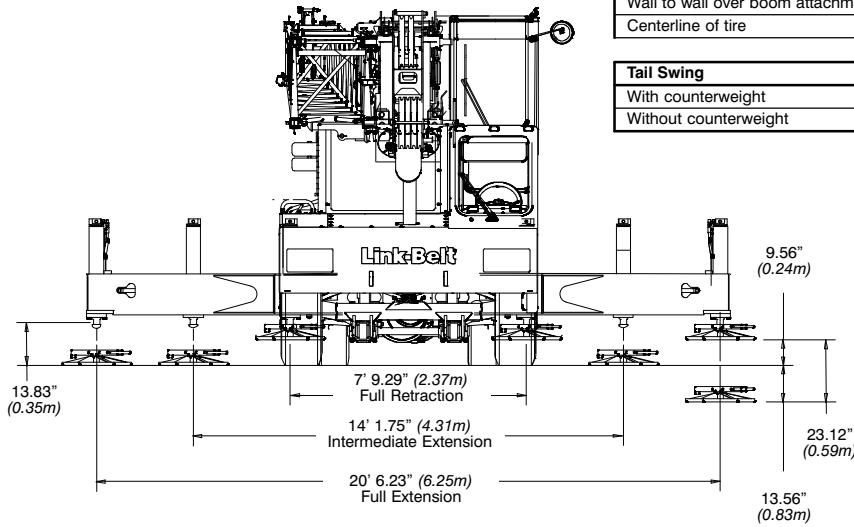

General Dimensions

■ Tier 3 / Stage IIIA

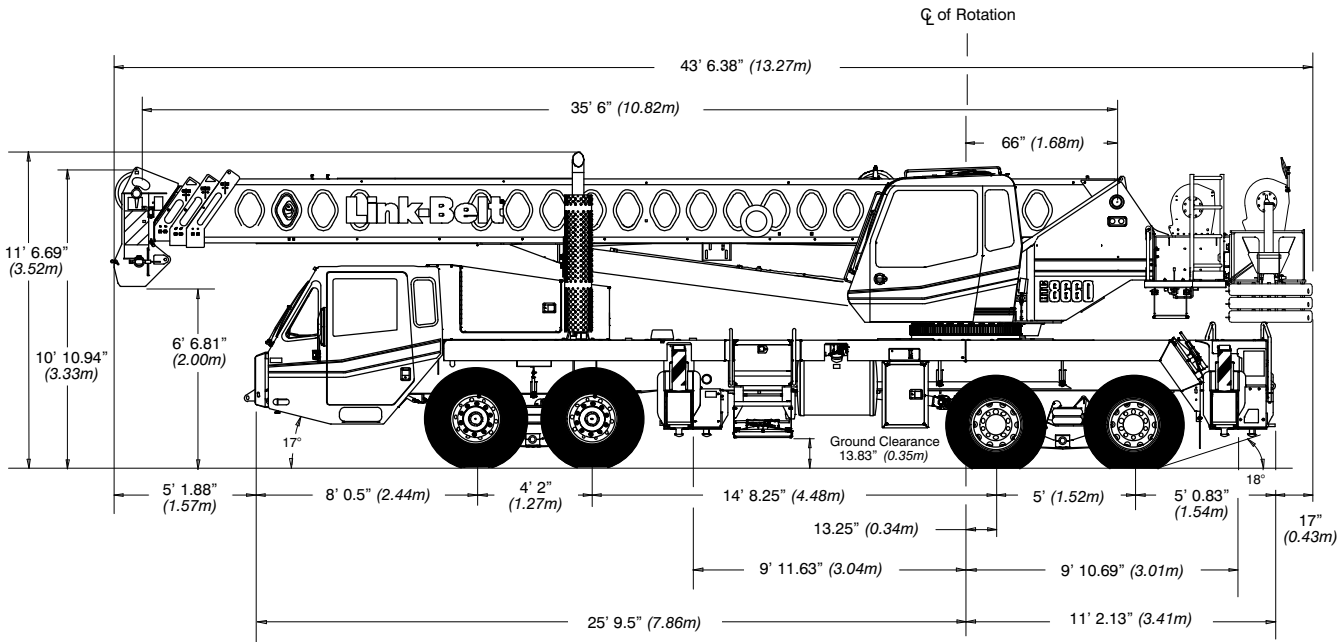

Turning Radius	English	Metric
Wall to wall over carrier	44' 1"	13.4m
Wall to wall over boom	45' 6"	13.9m
Wall to wall over boom attachment	46' 11"	14.3m
Centerline of tire	38' 7"	11.8m

Tail Swing	English	Metric
With counterweight	12' 8.5"	3.9m
Without counterweight	12' 5.25"	3.8m

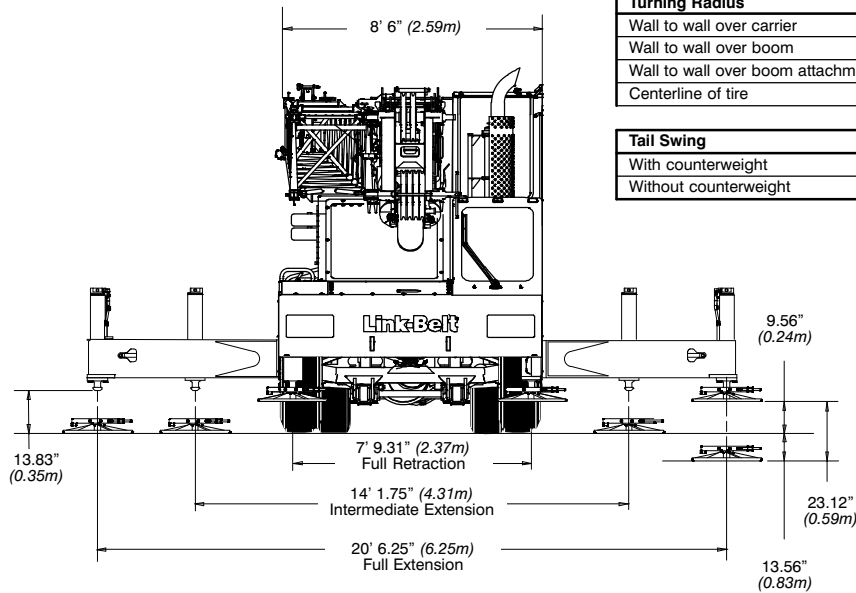

Working Range Diagram

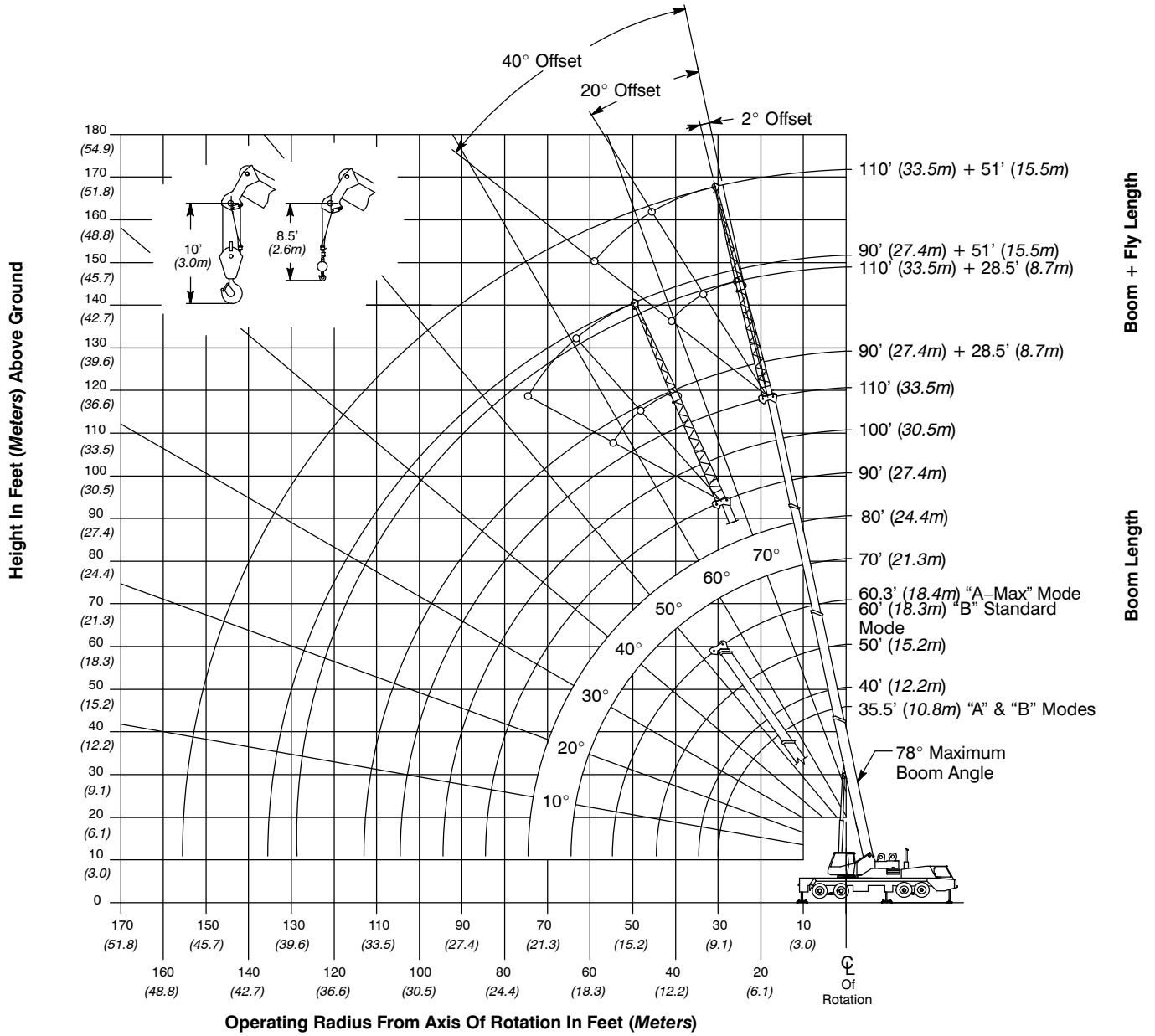

Note: Boom and fly geometry shown are for unloaded condition and crane standing level on firm supporting surface. Boom deflection, subsequent radius, and boom angle change must be accounted for when applying load to hook.



WARNING

Do Not Lower The Boom Below The Minimum Boom Angle For No Load Stability As Shown In The Lift Charts For The Boom Lengths Given. Loss Of Stability Will Occur Causing A Tipping Condition.

Boom Extend Modes

Boom Mode “A” (A–Max)
Only inner mid section telescopes

Boom Length
ft (m)

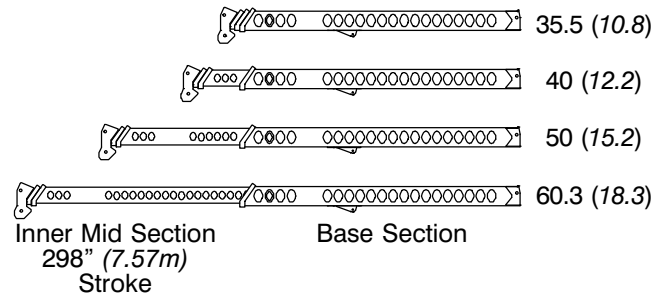

Boom Mode “B” (Standard)
Inner mid, outer mid, and tip sections telescope simultaneously

Boom Length
ft (m)

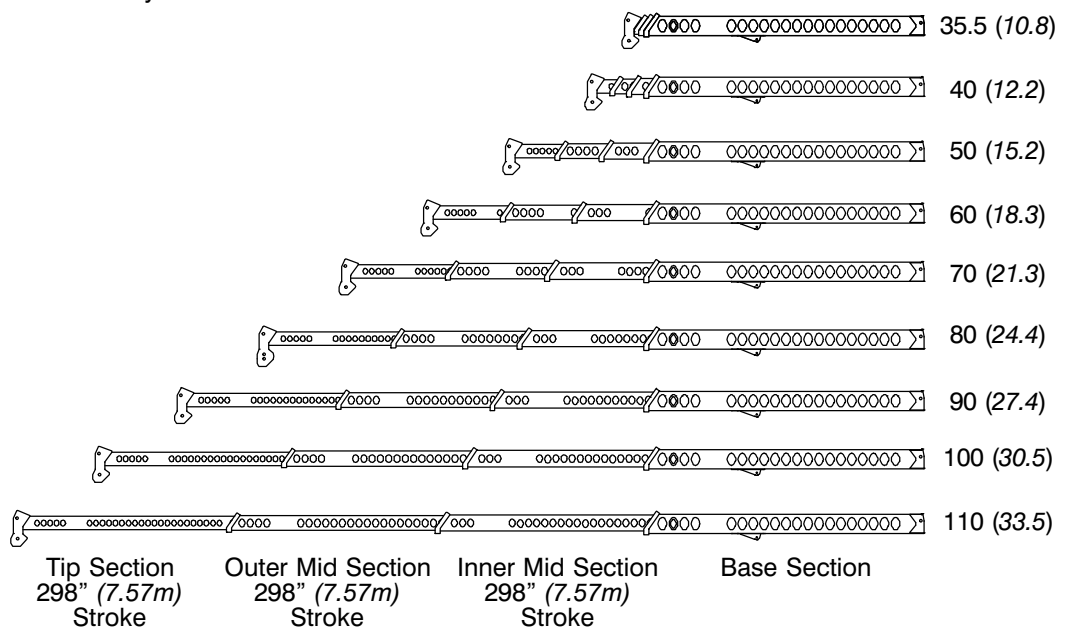

Main Boom Lift Capacity Charts – Standard

11,500 lb Counterweight – Fully Extended Outriggers – 360° Rotation (All Capacities Are Listed In Pounds)										
Radius (ft)	Boom Length (ft)									Radius (ft)
	35.5	40	50	60	70	80	90	100	110	
7	120,000*									7
10	100,000	80,900	72,800							10
12	76,000	73,200	65,800	50,900	37,900					12
15	65,800	63,600	57,700	47,300	37,900	35,400				15
20	52,500	52,000	47,500	39,300	37,900	34,700	28,900			20
25	40,500	40,300	40,000	37,900	37,900	34,300	28,300	24,000	19,500	25
30		29,600	30,300	30,600	30,800	30,400	24,900	22,600	19,500	30
35			22,800	23,200	23,400	23,400	22,100	20,100	18,500	35
40			17,700	18,200	18,400	18,500	18,600	18,000	16,500	40
45				14,600	14,800	15,000	15,000	15,100	14,700	45
50				11,900	12,200	12,300	12,400	12,400	12,500	50
55					10,100	10,300	10,400	10,400	10,500	55
60					8,400	8,600	8,700	8,800	8,800	60
65						7,200	7,400	7,400	7,500	65
70						6,000	6,200	6,300	6,400	70
75							5,200	5,300	5,400	75
80							4,400	4,500	4,600	80
85								3,800	3,900	85
90								3,100	3,200	90
95									2,700	95
100									2,200	100

* Special Conditions Or Wire Rope Required

This information is not for crane operation. Operator must refer to the in-cab information for crane operation. Rated lifting capacities shown on fully extended outriggers do not exceed 85% of the tipping loads and on tires do not exceed 75% of the tipping loads.

11,500 lb Counterweight – On Tires – Stationary – Boom Centered Over Rear
(All Capacities Are Listed In Pounds)

Radius (ft)	Boom Length (ft)						Radius (ft)
	35.5	40	50	60	70	80	
10	49,000						10
12	44,800	37,900	23,100				12
15	37,000	37,400	24,500	15,800			15
20	23,600	23,900	24,500	17,600			20
25	16,400	16,700	17,300	17,600	13,300		25
30		12,300	12,800	13,100	13,300	13,200	30
35			9,700	10,100	10,300	10,500	35
40			7,500	7,800	8,100	8,200	40
45				6,200	6,400	6,500	45
50				4,800	5,000	5,200	50
55					4,000	4,100	55
60					3,100	3,200	60
65						2,500	65
70						1,900	70

11,500 lb Counterweight – On Tires – Pick & Carry (1 mph) – Boom Centered Over Rear
(All Capacities Are Listed In Pounds)

Radius (ft)	Boom Length (ft)						Radius (ft)
	35.5	40	50	60	70	80	
10	36,200						10
12	32,900	33,100					12
15	28,800	29,000	24,000				15
20	23,500	23,700	24,000	17,600			20
25	16,400	16,700	17,300	17,600	13,300		25
30		12,300	12,800	13,100	13,300	13,200	30
35			9,700	10,100	10,300	10,500	35
40			7,500	7,800	8,100	8,200	40
45				6,200	6,400	6,500	45
50				4,800	5,000	5,200	50
55					4,000	4,100	55
60					3,100	3,200	60
65						2,500	65
70						1,900	70

This information is not for crane operation. Operator must refer to the in-cab information for crane operation. Rated lifting capacities shown on fully extended outriggers do not exceed 85% of the tipping loads and on tires do not exceed 75% of the tipping loads.

Main Boom Lift Capacity Charts – Optional

15,100 lb Counterweight – Fully Extended Outriggers – 360° Rotation (All Capacities Are Listed In Pounds)											
Radius (ft)	Boom Length (ft)									Radius (ft)	
	35.5	40	50	60	70	80	90	100	110		
7	120,000*										7
10	100,000	80,900	72,800								10
12	76,000	73,200	65,800	50,900	37,900						12
15	65,800	63,600	57,700	47,300	37,900	35,400					15
20	53,400	52,000	47,500	39,300	37,900	34,700	28,900				20
25	41,900	41,700	40,300	37,900	37,900	34,300	28,300	24,000	19,500		25
30		32,900	33,600	33,900	32,900	30,400	24,900	22,600	19,500		30
35			25,400	25,800	25,900	26,100	22,100	20,100	18,500		35
40			19,900	20,400	20,600	20,700	19,800	18,000	16,500		40
45				16,500	16,700	16,800	16,900	16,200	14,700		45
50				13,500	13,800	13,900	14,000	14,100	13,300		50
55					11,500	11,700	11,800	11,800	11,900		55
60					9,700	9,900	10,000	10,100	10,200		60
65						8,400	8,600	8,600	8,700		65
70						7,100	7,300	7,400	7,500		70
75							6,200	6,300	6,400		75
80							5,300	5,400	5,500		80
85								4,600	4,700		85
90								4,000	4,000		90
95									3,400		95
100									2,900		100

* Special Conditions Or Wire Rope Required

This information is not for crane operation. Operator must refer to the in-cab information for crane operation. Rated lifting capacities shown on fully extended outriggers do not exceed 85% of the tipping loads and on tires do not exceed 75% of the tipping loads.

15,100 lb Counterweight – On Tires – Stationary – Boom Centered Over Rear
(All Capacities Are Listed In Pounds)

Radius (ft)	Boom Length (ft)						Radius (ft)
	35.5	40	50	60	70	80	
10	49,000						10
12	44,800	44,700					12
15	39,600	39,400	29,200				15
20	26,000	26,300	26,900	19,500			20
25	18,200	18,600	19,100	19,500	14,800		25
30		13,800	14,300	14,600	14,800	14,200	30
35			11,000	11,300	11,600	11,700	35
40			8,600	8,900	9,200	9,300	40
45				7,100	7,300	7,500	45
50				5,700	5,900	6,100	50
55					4,700	4,900	55
60					3,800	4,000	60
65						3,200	65
70						2,500	70

15,100 lb Counterweight – On Tires – Pick & Carry (1 mph) – Boom Centered Over Rear
(All Capacities Are Listed In Pounds)

Radius (ft)	Boom Length (ft)						Radius (ft)
	35.5	40	50	60	70	80	
10	36,200						10
12	32,900	33,100					12
15	28,800	29,000	29,200				15
20	23,500	23,700	24,000	19,500			20
25	18,200	18,600	19,100	19,500	14,800		25
30		13,800	14,300	14,600	14,800	14,200	30
35			11,000	11,300	11,600	11,700	35
40			8,600	8,900	9,200	9,300	40
45				7,100	7,300	7,500	45
50				5,700	5,900	6,100	50
55					4,700	4,900	55
60					3,800	4,000	60
65						3,200	65
70						2,500	70

This information is not for crane operation. Operator must refer to the in-cab information for crane operation. Rated lifting capacities shown on fully extended outriggers do not exceed 85% of the tipping loads and on tires do not exceed 75% of the tipping loads.

Fly Attachment Lift Capacity Charts – Optional

11,500 lb Counterweight – Fully Extended Outriggers – 360° Rotation (All Capacities Are Listed In Pounds)								
110 ft Main Boom Length 2° Fly Offset			110 ft Main Boom Length 20° Fly Offset			110 ft Main Boom Length 40° Fly Offset		
Radius (ft)	Fly Length (ft)		Radius (ft)	Fly Length (ft)		Radius (ft)	Fly Length (ft)	
	28.5	51		28.5	51		28.5	51
35	9,400		35			35		
40	9,400		40			40		
45	9,400	6,200	45	9,600		45		
50	9,400	6,200	50	9,200		50	7,600	
55	9,300	6,200	55	8,600		55	7,400	
60	8,600	6,200	60	8,000	4,900	60	7,200	
65	8,000	6,100	65	7,400	4,700	65	7,000	
70	7,000	5,800	70	7,000	4,500	70	6,600	
75	6,000	5,400	75	6,500	4,300	75	6,200	3,500
80	5,200	5,000	80	5,600	4,200	80	5,900	3,400
85	4,400	4,700	85	4,800	4,000	85	5,200	3,300
90	3,800	4,300	90	4,200	3,900	90	4,400	3,300
95	3,200	3,700	95	3,600	3,700	95	3,800	3,200
100	2,700	3,200	100	3,000	3,600	100	3,200	3,200
105	2,300	2,700	105	2,500	3,300	105	2,700	3,100
110	1,900	2,300	110	2,100	2,800	110	2,200	3,100
115	1,500	2,000	115	1,700	2,400	115		2,700
120	1,200	1,600	120	1,300	2,000	120		2,300
125		1,300	125		1,700	125		1,900
130			130		1,300	130		1,500
135			135			135		1,100

This information is not for crane operation. Operator must refer to the in-cab information for crane operation. Rated lifting capacities shown on fully extended outriggers do not exceed 85% of the tipping loads and on tires do not exceed 75% of the tipping loads.

15,100 lb Counterweight – Fully Extended Outriggers – 360° Rotation (All Capacities Are Listed In Pounds)								
110 ft Main Boom Length 2° Fly Offset			110 ft Main Boom Length 20° Fly Offset			110 ft Main Boom Length 40° Fly Offset		
Radius (ft)	Fly Length (ft)		Radius (ft)	Fly Length (ft)		Radius (ft)	Fly Length (ft)	
	28.5	51		28.5	51		28.5	51
35	9,400		35			35		
40	9,400		40			40		
45	9,400	6,200	45	9,600		45		
50	9,400	6,200	50	9,200		50	7,600	
55	9,300	6,200	55	8,600		55	7,400	
60	8,600	6,200	60	8,000	4,900	60	7,200	
65	8,000	6,100	65	7,400	4,700	65	7,000	
70	7,500	5,800	70	7,000	4,500	70	6,600	
75	7,000	5,400	75	6,500	4,300	75	6,200	3,500
80	6,100	5,000	80	6,200	4,200	80	5,900	3,400
85	5,300	4,700	85	5,700	4,000	85	5,600	3,300
90	4,600	4,400	90	5,000	3,900	90	5,200	3,300
95	4,000	4,100	95	4,300	3,700	95	4,500	3,200
100	3,500	3,900	100	3,700	3,600	100	3,900	3,200
105	3,000	3,400	105	3,200	3,400	105	3,400	3,100
110	2,500	3,000	110	2,700	3,300	110	2,800	3,100
115	2,200	2,600	115	2,300	3,000	115		3,000
120	1,800	2,200	120	1,900	2,600	120		2,800
125	1,500	1,900	125	1,500	2,200	125		2,400
130	1,200	1,600	130		1,900	130		2,000
135		1,300	135		1,600	135		1,700
140			140		1,300	140		

This information is not for crane operation. Operator must refer to the in-cab information for crane operation. Rated lifting capacities shown on fully extended outriggers do not exceed 85% of the tipping loads and on tires do not exceed 75% of the tipping loads.

Main Boom Lift Capacity Charts – Optional (Metric)

5.2t Counterweight – Fully Extended Outriggers – 360° Rotation (All Capacities Are Listed In Kilograms)										
Radius (m)	Boom Length (m)									Radius (m)
	10.82	12.2	15.2	18.3	21.3	24.4	27.4	30.5	33.53	
2.5	50 000									2.5
3	45 360	36 650	33 300							3
3.5	35 200	34 100	30 600							3.5
4	32 600	31 450	28 300	23 050	17 150					4
4.5	30 200	29 150	26 400	21 650	17 150					4.5
5	28 050	27 300	24 700	20 200	17 150	16 050				5
6	24 200	23 900	21 800	18 000	17 150	15 700	13 100			6
7	19 850	19 650	19 350	17 150	17 150	15 700	13 100	10 850		7
8	15 100	15 350	15 550	15 700	15 800	15 100	12 450	10 850	8 800	8
9	11 950	12 200	12 450	12 600	12 650	12 750	11 450	10 350	8 800	9
10		9 950	10 300	10 400	10 500	10 550	10 550	9 550	8 800	10
12			7 300	7 500	7 550	7 600	7 650	7 650	7 600	12
14				5 600	5 700	5 750	5 800	5 800	5 850	14
16				4 300	4 450	4 500	4 550	4 550	4 600	16
18					3 450	3 550	3 600	3 600	3 650	18
20						2 800	2 850	2 900	2 950	20
22						2 250	2 300	2 350	2 350	22
24							1 850	1 850	1 900	24
26								1 500	1 500	26
28								1 150	1 200	28
30									900	30

This information is not for crane operation. Operator must refer to the in-cab information for crane operation. Rated lifting capacities shown on fully extended outriggers do not exceed 75% of the tipping loads and on tires do not exceed 65% of the tipping loads.

5.2t Counterweight – On Tires – Stationary – Boom Centered Over Rear (All Capacities Are Listed In Kilograms)							
Radius (m)	Boom Length (m)						Radius (m)
	10.82	12.2	15.2	18.3	21.3	24.4	
3	22 400						3
3.5	20 800	17 150					3.5
4	17 950	17 150					4
4.5	14 900	15 050	9 850				4.5
5	12 650	12 800	9 850				5
6	9 500	9 650	9 850	7 900			6
7	7 400	7 550	7 750	7 900			7
8	5 900	6 050	6 250	6 400	5 350		8
9	4 800	4 950	5 150	5 300	5 350	5 400	9
10		4 100	4 300	4 450	4 500	4 600	10
12			3 050	3 150	3 250	3 300	12
14				2 300	2 400	2 450	14
16				1 650	1 750	1 800	16
18					1 250	1 350	18
20						950	20
22						650	22

5.2t Counterweight – On Tires – Pick & Carry (1.6km/h) – Boom Centered Over Rear (All Capacities Are Listed In Kilograms)							
Radius (m)	Boom Length (m)						Radius (m)
	10.82	12.2	15.2	18.3	21.3	24.4	
3	16 550						3
3.5	15 300	15 350					3.5
4	14 200	14 250					4
4.5	13 200	13 300	9 850				4.5
5	12 300	12 400	9 850				5
6	9 500	9 650	9 850	7 900			6
7	7 400	7 550	7 750	7 900			7
8	5 900	6 050	6 250	6 400	5 350		8
9	4 800	4 950	5 150	5 300	5 350	5 400	9
10		4 100	4 300	4 450	4 500	4 600	10
12			3 050	3 150	3 250	3 300	12
14				2 300	2 400	2 450	14
16				1 650	1 750	1 800	16
18					1 250	1 350	18
20						950	20
22						650	22

This information is not for crane operation. Operator must refer to the in-cab information for crane operation. Rated lifting capacities shown on fully extended outriggers do not exceed 75% of the tipping loads and on tires do not exceed 65% of the tipping loads.

6.8t Counterweight – Fully Extended Outriggers – 360° Rotation (All Capacities Are Listed In Kilograms)										
Radius (m)	Boom Length (m)									Radius (m)
	10.82	12.2	15.2	18.3	21.3	24.4	27.4	30.5	33.53	
2.5	50 000									2.5
3	45 360	36 650	33 300							3
3.5	35 200	34 100	30 600							3.5
4	32 600	31 450	28 300	23 050	17 150					4
4.5	30 200	29 150	26 400	21 650	17 150					4.5
5	28 050	27 300	24 700	20 200	17 150	16 050				5
6	24 550	23 900	21 800	18 000	17 150	15 700	13 100			6
7	21 000	20 900	19 550	17 150	17 150	15 700	13 100	10 850		7
8	16 750	16 950	17 150	17 150	16 650	15 100	12 450	10 850	8 800	8
9	13 050	13 550	13 850	13 950	14 050	13 900	11 450	10 350	8 800	9
10		11 100	11 450	11 550	11 600	11 650	10 550	9 550	8 800	10
12			8 200	8 400	8 450	8 500	8 550	8 250	7 600	12
14				6 350	6 450	6 500	6 500	6 550	6 550	14
16				4 900	5 050	5 100	5 150	5 200	5 200	16
18					4 000	4 100	4 150	4 150	4 200	18
20						3 300	3 350	3 400	3 400	20
22						2 650	2 700	2 750	2 800	22
24							2 200	2 250	2 300	24
26								1 850	1 850	26
28								1 500	1 500	28
30									1 200	30

This information is not for crane operation. Operator must refer to the in-cab information for crane operation. Rated lifting capacities shown on fully extended outriggers do not exceed 75% of the tipping loads and on tires do not exceed 65% of the tipping loads.

6.8t Counterweight – On Tires – Stationary – Boom Centered Over Rear (All Capacities Are Listed In Kilograms)							
Radius (m)	Boom Length (m)						Radius (m)
	10.82	12.2	15.2	18.3	21.3	24.4	
3	22 350						3
3.5	20 800	17 150					3.5
4	19 400	17 150					4
4.5	16 300	16 450	13 400				4.5
5	13 850	14 000	13 400				5
6	10 450	10 600	10 800	8 700			6
7	8 200	8 350	8 550	8 700			7
8	6 600	6 750	6 950	7 100	5 950		8
9	5 400	5 550	5 750	5 900	5 950	6 000	9
10		4 600	4 850	4 950	5 050	5 100	10
12			3 500	3 600	3 700	3 750	12
14				2 650	2 750	2 800	14
16				2 000	2 050	2 150	16
18					1 550	1 600	18
20						1 200	20
22						850	22

6.8t Counterweight – On Tires – Pick & Carry (1.6km/h) – Boom Centered Over Rear (All Capacities Are Listed In Kilograms)							
Radius (m)	Boom Length (m)						Radius (m)
	10.82	12.2	15.2	18.3	21.3	24.4	
3	16 500						3
3.5	15 300	15 350					3.5
4	14 200	14 250					4
4.5	13 200	13 300	13 400				4.5
5	12 300	12 400	12 500				5
6	10 450	10 600	10 800	8 700			6
7	8 200	8 350	8 550	8 700			7
8	6 600	6 750	6 950	7 100	5 950		8
9	5 400	5 550	5 750	5 900	5 950	6 000	9
10		4 600	4 850	4 950	5 050	5 100	10
12			3 500	3 600	3 700	3 750	12
14				2 650	2 750	2 800	14
16				2 000	2 050	2 150	16
18					1 550	1 600	18
20						1 200	20
22						850	22

This information is not for crane operation. Operator must refer to the in-cab information for crane operation. Rated lifting capacities shown on fully extended outriggers do not exceed 75% of the tipping loads and on tires do not exceed 65% of the tipping loads.

Fly Attachment Lift Capacity Charts – Optional (Metric)

5.2t Counterweight – Fully Extended Outriggers – 360° Rotation (All Capacities Are Listed In Kilograms)								
33.53m Main Boom Length 2° Fly Offset			33.53m Main Boom Length 20° Fly Offset			33.53m Main Boom Length 40° Fly Offset		
Radius (m)	Fly Length (m)		Radius (m)	Fly Length (m)		Radius (m)	Fly Length (m)	
	8.69	15.54		8.69	15.54		8.69	15.54
12	4 300		12			12		
14	4 300	2 800	14	4 300		14		
16	4 300	2 800	16	4 050		16	3 400	
18	3 900	2 800	18	3 650	2 250	18	3 300	
20	3 200	2 750	20	3 350	2 100	20	3 150	
22	2 600	2 550	22	2 800	2 000	22	2 900	1 600
24	2 150	2 300	24	2 350	1 900	24	2 500	1 550
26	1 750	1 950	26	1 900	1 800	26	2 050	1 500
28	1 400	1 600	28	1 550	1 750	28	1 650	1 450
30	1 150	1 350	30	1 250	1 550	30	1 350	1 450
32	900	1 100	32	1 000	1 300	32	1 050	1 400
34	700	900	34	800	1 050	34	800	1 200
36	500	700	36	550	850	36		950
38		550	38		650	38		750
40			40		500	40		550

This information is not for crane operation. Operator must refer to the in-cab information for crane operation. Rated lifting capacities shown on fully extended outriggers do not exceed 75% of the tipping loads and on tires do not exceed 65% of the tipping loads.

6.8t Counterweight – Fully Extended Outriggers – 360° Rotation (All Capacities Are Listed In Kilograms)								
33.53m Main Boom Length 2° Fly Offset			33.53m Main Boom Length 20° Fly Offset			33.53m Main Boom Length 40° Fly Offset		
Radius (m)	Fly Length (m)		Radius (m)	Fly Length (m)		Radius (m)	Fly Length (m)	
	8.69	15.54		8.69	15.54		8.69	15.54
12	4 300		12			12		
14	4 300	2 800	14	4 300		14		
16	4 300	2 800	16	4 050		16	3 400	
18	3 950	2 800	18	3 650	2 250	18	3 300	
20	3 600	2 750	20	3 350	2 100	20	3 150	
22	3 050	2 550	22	3 050	2 000	22	2 900	1 600
24	2 500	2 300	24	2 700	1 900	24	2 700	1 550
26	2 100	2 100	26	2 250	1 800	26	2 400	1 500
28	1 750	1 950	28	1 900	1 750	28	2 000	1 450
30	1 450	1 650	30	1 550	1 650	30	1 650	1 450
32	1 200	1 350	32	1 300	1 550	32	1 350	1 400
34	950	1 150	34	1 050	1 300	34	1 050	1 400
36	750	950	36	800	1 100	36		1 200
38	600	750	38	600	900	38		1 000
40	450	600	40		700	40		750
42			42		550	42		550

This information is not for crane operation. Operator must refer to the in-cab information for crane operation. Rated lifting capacities shown on fully extended outriggers do not exceed 75% of the tipping loads and on tires do not exceed 65% of the tipping loads.

This page intentionally left blank

This page intentionally left blank

This page intentionally left blank

Link-Belt Construction Equipment Company Lexington, Kentucky www.linkbelt.com

®Link-Belt is a registered trademark. Copyright 2016. We are constantly improving our products and therefore reserve the right to change designs and specifications.