



**Link-Belt**  
C R A N E S

# HTC 8675 II SERIES

# HTT 8675 II SERIES

**75 U.S. ton | 70 metric ton Hydraulic Truck Crane**  
**75 U.S. ton | 70 metric ton Truck Terrain Crane**

- 41-127 ft (12.5-38.7 m) four-section, latching boom with no charted capacity deductions for telescoping loads.
- 38-64 ft (11.6-19.5 m) two-piece, bi-fold, on-board lattice attachment with 2°, 15°, 30°, 45° offsets - optional
- Two 16 ft (4.9 m) lattice inserts provide a total attachment length of 96 ft (29.3 m) - optional
- 237 ft (72.2 m) maximum tip height
- Modular style counterweights
- 16,880 lbs (7 656.6 kg) maximum winch line pull
- 460 fpm (140.2 m/min) maximum winch line speed
- Next generation operator's cab with improved visibility and ergonomics
- Automated Manual Transmission
- Front and rear air ride suspension
- Anti-lock (ABS) brakes
- Three lockable storage boxes
- "Stow 'n Go" steel pontoons



# HTC 8675 II

- 4-section full power latching boom with attachment flexibility
- Big, wide cab with outstanding visibility
- Winches deliver impressive numbers of line pull and line speed
- Counterweight flexibility, big engine and transmission power, along with air-ride promise incredible mobility on the road or on the job



38-64 ft (11.67-19.5 m)  
two-piece bi-fold, lattice  
attachment with 2°, 15°, 30°,  
and 45° offsets

## Outstanding mobility on the road and on the job site

- Cruise control
- Three stage engine **compression brake**
- Ether injection system—**optional**
- **Automated transmission** (no clutch pedal) —12 speeds forward, 2 speeds reverse with two modes of operation: **fully automatic and semi-automatic**
- Job site travel is **permissible with counterweight** for exceptional job site versatility.



- **Comfortable carrier cab:**
  - Dash-mounted **comprehensive instrumentation** with back-lit gauge
  - Roll up/down door window provides **excellent ventilation**
  - Fully adjustable **air-ride fabric seat**
  - **Suspended pedals**

- **Boom dolly/trailer ready** when equipped with optional boom float kit, rear electrical and air connections.

Optional rear electrical and air connections



All counterweight configurations can be raised and lowered by controls located on each side of the upper structure for ease of installation and removal

There are two standard **locking storage boxes** with options for up to three boxes

**Air-ride suspension** front and rear provides a smooth ride and precise handling. Optional air-ride lift system holds the rear suspension retracted while the crane is on outriggers.



# 4-section latching boom with attachment flexibility

- 41-127 ft (12.5-38.7 m) latching boom with four boom modes for superior capacities throughout the extension range
- No charted capacity reductions for telescoping loads
- Boom requires no greasing because of ingenious Teflon wear pucks impregnated in the full contact wear pads
- No minimum boom angle for extending or retracting the boom sections
- 38-64 ft (11.6-19.5 m) two-piece, bi-fold, on board lattice attachment with 2°, 15°, 30°, and 45° offsets
- Two 16 ft (4.9 m) lattice inserts provide a total attachment length of 90 ft (27.4 m)
- 230 ft (70.2 m) maximum tip height



Quick reeve boom head eliminates the need to remove the bucket when it becomes necessary to change the reeving.



Innovative two-part paint coating technology, coupled with pre-assembly paint process, provides the finest quality coating system available today.



Right side viewing camera

Large west coast-style rear viewing mirrors

Non-slip surface strips on carrier deck

Daytime running lights

Self-storing fifth outrigger pontoon

Large engine doors allow for easy access

Integrated air conditioning (not a roof-mounted system)

Aluminum wheels and radial tires with chrome and stainless wheel accents

Full air, S-cam anti-lock (ABS) brakes on all wheel ends with automatic slack adjusters



Integrated air conditioning

Swing camera

Folding viewing mirror for travel

Mechanical boom angle indicator - standard

Outrigger position sensing (OSHA)



Carrier-mounted outrigger controls, located on each side of the carrier, include an engine throttle-up switch for fast outrigger deployment. For fine level adjusting of the carrier, throttle can be taken down to idle.

\*North American model with EPA 2013 engine shown

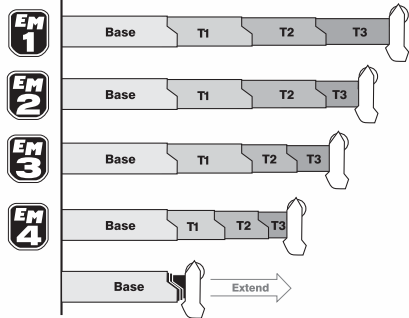

### Powerful and responsive hydraulics

- Six pump, pressure compensated hydraulic system allows simultaneous and precise function of boom hoist, winch and swing.
- Two-speed hydraulic piston motor system delivers superior hoisting. Matched size optional front and rear winches provide equal max line pulls of 16,880 lbs (75.0 kn) and max line speeds of 460 fpm (140.2 m/min) on 16" (.41 m) root diameter grooved drums.
- Drum rotation indicators - standard.
- Bi-directional hydraulic swing motor mounted to a planetary reduction unit for 360° swing. Spring applied hydraulic released 360° swing park brake provides infinite swing park positions as well as free swing when control is in a neutral position.

### Steerable all wheel axles, in conjunction with super single tires, makes the HTT even harder to beat on the job-site, and NO changes to the on-outrigger capacity charts.

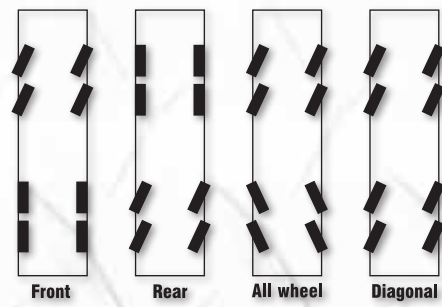

- Drive and steer capabilities for the rear axles
- Four steering modes:
  - Independent front, Independent rear, All wheel, Diagonal
- Rear axles self-center and lock in the straight ahead position for high speed travel
- Turning radius under 29 ft (8.8 m) at the edge of the tire
- 445/65R22.5 tires front and rear that are interchangeable
- Only one spare rim and tire combination is needed
- Transverse (cross-axle) differential locks that greatly improve traction on unimproved job-site conditions.

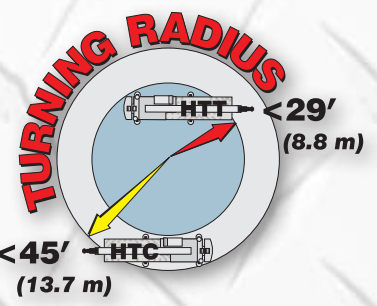
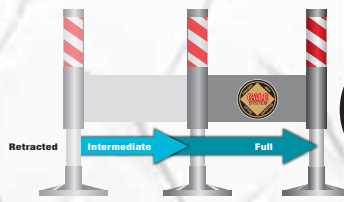

### The Confined Area Lifting Capacities (CALC) system provides three outrigger positions:

- full retraction
  - intermediate extension
  - full extension
- Outrigger pins eliminate guesswork by automatically positioning outriggers at midpoint position.



Stow 'n Go outrigger pontoons are quickly and easily stored and secured for travel, eliminating the need to remove the pontoon each time the crane moves. Pontoon storage space is also available on rear fenders and side access ladders.

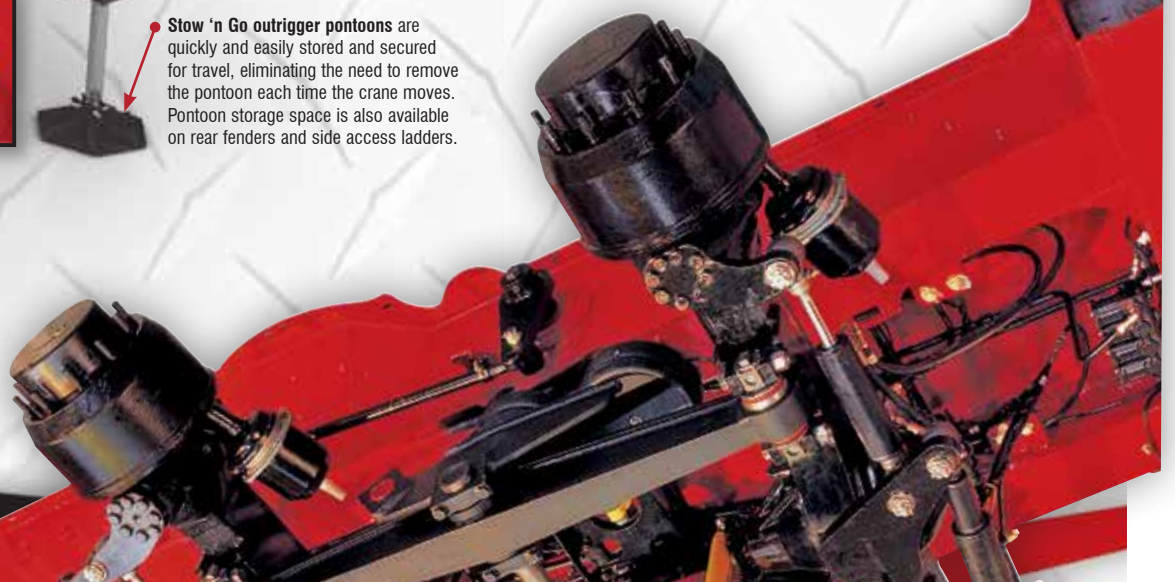



## Roomier and quieter operator's cab

- **Extra large front window** seamlessly merges into the roof window
- Sliding left side door, right and rear windows, and swing up top window provide **excellent ventilation**
- All gauges, switches, indicators and controls are placed in the operators forward line of sight for **excellent ergonomics**
- **All gauges and switches are backlit** for excellent visibility when the cab working lights are switched to the on position
- **Integrated air conditioning** utilizes the same ventilation outlets as the standard heating system

## Total crane operating system

### Link-Belt PULSE

Link-Belt Pulse is the Link-Belt designed total crane operating system. It includes the rated capacity limiter, boom extend mode controller (EMC), self-diagnostic capabilities and continuous monitoring of multiple crane functions and conditions. To aid operators in a safe and efficient operation, its high-resolution, color-intense graphic display provides excellent contrast even in direct sunlight.



## Superior accessibility

Access to the operator's cab and engine compartment is superb with strategically located ladders and steps. The pull-out CabWalk™ slides out from its secured travel position underneath the operator's cab to give the operator a platform to stand on for easy entry and exit from the cab.



Out of cab external light bar



Internal light bar



## Multiple counterweight configurations give you capacities for any size job

- Standard - total of 10,800 lbs (4.8 mt) of removable counterweights. Capacities for four different counterweight configurations.
- Optional - up to 18,400 lbs (8.2 mt) of removable counterweights. Capacities for up to six different counterweight configurations.
- All configurations can be raised and lowered by controls located on each side of the upper structure for ease of installation and removal.



## Telematics. You own the data!

Cellular-based data logging and monitoring system that provides:

- Viewing options for sharing data with distributor and Link-Belt
- Location and operational settings
- Monitor routine maintenance intervals
- Crane and engine monitoring
- Diagnostic and fault codes



Link-Belt Construction Equipment Company is a leader in the design, manufacture and sales of telescopic and lattice boom cranes with headquarters and manufacturing facilities in Lexington, Kentucky, USA. Link-Belt is committed to the manufacture and service of high quality products that satisfy customers worldwide

Towards that end, Link-Belt has pursued a strategy of growth and investment. It has moved aggressively to seize more global market share by producing a broader range of products and strengthening distribution and personnel around the globe.

Link-Belt is also home to a family of passionate professionals with a legacy of innovation and cutting-edge technology spanning over 140 years. These professionals, in a 740,000 sq. ft. (68 748 m2) manufacturing facility and with a culture of continuous innovation, have pushed Link-Belt to be the most modern crane manufacturer in North America.

**Your crane investment is always protected...  
with your Link-Belt distributor.**

When you invest in a Link-Belt crane, you invest in a legacy of outstanding customer support dating back to 1874. The ultimate value of a machine begins with state-of-the-art design and quality manufacturing, but it is the excellent Link-Belt distributor product support that determines its long term value. This philosophy has earned Link-Belt cranes the enviable position of traditionally commanding some of the highest resale prices in the industry.

*"... to be recognized as a*  
**leader in**  
**customer service & satisfaction."**  
*— The Link-Belt Vision*

**Link-Belt®**  
*Preferred*

**As a member of Link-Belt Cranes user's group, you will have access to:**

- A comprehensive online library of all parts, service and operator manuals for YOUR crane
- Interactive, live groundbearing calculations for YOUR crane
- Plus a vast array of information on new products, services and special offerings
- Online access to recommended spare parts lists, filter, lube and key lists plus maintenance information and more
- No annual fee or charges to access your crane information

**Link-Belt was born because our founding father understood the importance of replacement parts.**

William Banta Everett

**Building on that principal...**

- Trained technical specialists
- Faster and more efficient customer service
- State of the art computer information systems
- 24 hours a day, 7 days a week
- 72,000 Sq. Ft. Parts Distribution Center
- All parts in stock ship the same business day

**Link-Belt CRANES GENUINE PARTS**

# Technical Data

## Specifications & Capacities

# HTT 8675

**Series II**  
**Telescopic Boom Truck Crane**  
**75 US ton**  
**70 metric ton**

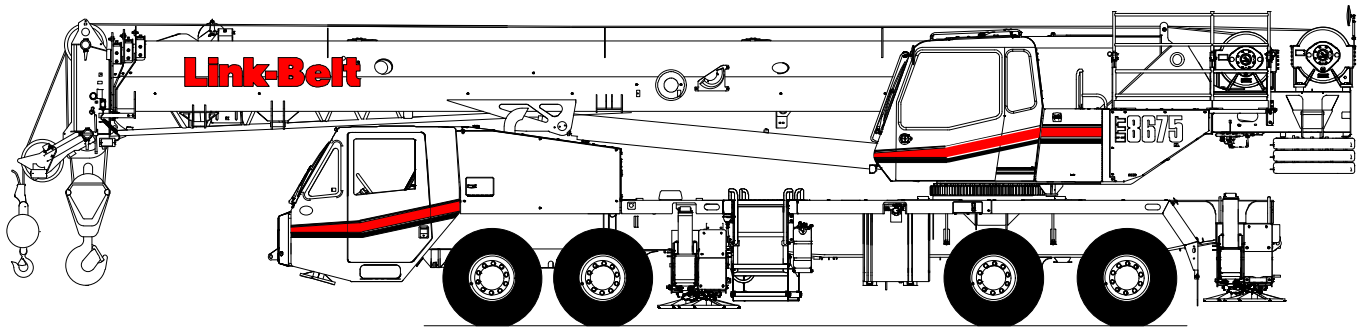

**CAUTION:** This material is supplied for reference use only. Operator must refer to in-cab Crane Rating Manual and Operator's Manual to determine allowable crane lifting capacities and assembly and operating procedures.





# Table Of Contents

<b>Boom, Attachments, and Upper Structure</b> .....	<b>1</b>
Boom .....	1
Boom .....	1
Boom Wear Pads .....	1
Boom Head .....	1
Boom Elevation .....	1
Auxiliary Lifting Sheave – Optional .....	1
Hook Blocks and Balls – Optional .....	1
Fly – Optional .....	1
Fly Extensions – Optional .....	1
Upper Operator’s Cab and Controls .....	1
Swing .....	2
Electrical .....	2
Load Hoist System .....	3
Load Hoist Performance .....	3
2M Main and Optional Auxiliary Winches .....	3
Hydraulic System .....	3
Counterweight .....	3
<b>Carrier</b> .....	<b>5</b>
General .....	5
Outriggers .....	5
Steering and Axles .....	5
Suspension .....	5
Tires and Wheels .....	5
Brakes .....	5
Electrical .....	5
Engine .....	6
Transmission .....	6
Carrier Speeds and Gradeability .....	7
Fuel Tank .....	7
Hydraulic System .....	7
Pump Drive .....	7
Lower Cab and Controls .....	8
Additional Equipment .....	8
<b>Axle Loads</b> .....	<b>9</b>
<b>Axle Loads with 2–Axle or 3–Axle Boom Dolly</b> .....	<b>10</b>
<b>General Dimensions</b> .....	<b>11</b>
EPA 2013 .....	11
<b>General Dimensions</b> .....	<b>12</b>

Tier 3 / Stage IIIA .....	12
<b>Working Range Diagram .....</b>	<b>13</b>
<b>Boom Extend Modes .....</b>	<b>14</b>
<b>Main Boom Lift Capacity Charts – Standard .....</b>	<b>15</b>
0 lb Counterweight – Fully Extended Outriggers – 360° Rotation .....	15
0 lb Counterweight – On Tires – Stationary – Boom Centered Over Rear .....	16
0 lb Counterweight – On Tires – Pick & Carry (1 mph) – Boom Centered Over Rear .....	16
10,800 lb Counterweight – Fully Extended Outriggers – 360° Rotation .....	17
10,800 lb Counterweight – On Tires – Stationary – Boom Centered Over Rear .....	18
10,800 lb Counterweight – On Tires – Pick & Carry (1 mph) – Boom Centered Over Rear .....	18
<b>Main Boom Lift Capacity Charts – Optional .....</b>	<b>19</b>
14,400 lb Counterweight – Fully Extended Outriggers – 360° Rotation .....	19
14,400 lb Counterweight – On Tires – Stationary – Boom Centered Over Rear .....	20
14,400 lb Counterweight – On Tires – Pick & Carry (1 mph) – Boom Centered Over Rear .....	20
18,400 lb Counterweight – Fully Extended Outriggers – 360° Rotation .....	21
18,400 lb Counterweight – On Tires – Stationary – Boom Centered Over Rear .....	22
18,400 lb Counterweight – On Tires – Pick & Carry (1 mph) – Boom Centered Over Rear .....	22
<b>Fly Attachment Lift Capacity Charts – Optional .....</b>	<b>23</b>
0 lb Counterweight – Fully Extended Outriggers – 360° Rotation .....	23
98.7 ft Main Boom Length – 38 ft Offset Fly Length .....	23
127 ft Main Boom Length – 38 ft Offset Fly Length .....	24
10,800 lb Counterweight – Fully Extended Outriggers – 360° Rotation .....	25
98.7 ft Main Boom Length .....	25
127 ft Main Boom Length .....	27
14,400 lb Counterweight – Fully Extended Outriggers – 360° Rotation .....	29
98.7 ft Main Boom Length .....	29
127 ft Main Boom Length .....	31
18,400 lb Counterweight – Fully Extended Outriggers – 360° Rotation .....	33
98.7 ft Main Boom Length .....	33
127 ft Main Boom Length .....	35
<b>Main Boom Lift Capacity Charts – Optional (Metric) .....</b>	<b>37</b>
0t Counterweight – Fully Extended Outriggers – 360° Rotation .....	37
0t Counterweight – On Tires – Stationary – Boom Centered Over Rear .....	38
0t Counterweight – On Tires – Pick & Carry (1 km/h) – Boom Centered Over Rear .....	38
4.8t Counterweight – Fully Extended Outriggers – 360° Rotation .....	39
4.8t Counterweight – On Tires – Stationary – Boom Centered Over Rear .....	40
4.8t Counterweight – On Tires – Pick & Carry (1 km/h) – Boom Centered Over Rear .....	40
6.4t Counterweight – Fully Extended Outriggers – 360° Rotation .....	41
6.4t Counterweight – On Tires – Stationary – Boom Centered Over Rear .....	42
6.4t Counterweight – On Tires – Pick & Carry (1 km/h) – Boom Centered Over Rear .....	42
8.2t Counterweight – Fully Extended Outriggers – 360° Rotation .....	43
8.2t Counterweight – On Tires – Stationary – Boom Centered Over Rear .....	44
8.2t Counterweight – On Tires – Pick & Carry (1 km/h) – Boom Centered Over Rear .....	44
<b>Fly Attachment Lift Capacity Charts – Optional (Metric) .....</b>	<b>45</b>

0t Counterweight – Fully Extended Outriggers – 360° Rotation .....	45
30.1m Main Boom Length – 11.58m Offset Fly Length .....	45
38.71m Main Boom Length – 11.58m Offset Fly Length .....	45
4.8t Counterweight – Fully Extended Outriggers – 360° Rotation .....	46
30.1m Main Boom Length .....	46
38.71m Main Boom Length .....	47
6.4t Counterweight – Fully Extended Outriggers – 360° Rotation .....	48
30.1m Main Boom Length .....	48
38.71m Main Boom Length .....	49
8.2t Counterweight – Fully Extended Outriggers – 360° Rotation .....	50
30.1m Main Boom Length .....	50
38.71m Main Boom Length .....	51

**This Page Intentionally Blank**

# Boom, Attachments, and Upper Structure

## ■ Boom

**Design** — Four section, formed construction of extra high tensile steel consisting of one base section and three telescoping sections. The two plate design of each section has multiple longitudinal bends for superior strength. Each telescoping section extends independently by means of one double-acting, single stage hydraulic cylinder with integrated holding valves.

### Boom

- 41–127 ft (12.5–38.71m) four section boom
- Integral boom dolly connection
- Four boom extend modes (EM1 through EM4), controlled from the operator's cab, provide superior capacities by varying the extension of the telescoping sections:
  - EM1 extends to 127.0 ft (38.71m)
  - EM2 extends to 113.1 ft (34.5m)
  - EM3 extends to 98.7 ft (30.1m)
  - EM4 extends to 76.0 ft (23.2m)
- Mechanical boom angle indicator
- Maximum tip height for each extend mode is:
  - EM1 is 136 ft (41.5m)
  - EM2 is 122 ft (37.3m)
  - EM3 is 108 ft (33.0m)
  - EM4 is 86 ft (26.2m)

### Boom Wear Pads

- Wear pads with Teflon inserts that self-lubricate the boom sections
- Bottom wear pads are universal for all boom sections
- Top wear pads are universal for all boom sections

### Boom Head

- Five 16.5 in (41.9cm) root diameter nylon sheaves to handle up to ten parts of line
- Easily removable wire rope guards
- Rope dead end lugs on each side of the boom head
- Boom head is designed for quick-reeve of the hook block

### Boom Elevation

- One double acting hydraulic cylinder with integral holding valve
- Boom elevation:  $-3^{\circ}$  to  $80^{\circ}$

### Auxiliary Lifting Sheave — Optional

- Single 16.5 in (41.9m) root diameter nylon sheave
- Easily removable wire rope guards
- Does not affect erection of the fly or use of the main head sheaves

### Hook Blocks and Balls — Optional

- 40 ton (36.3mt) 4 sheave quick-reeve hook block with safety latch
- 60 ton (54.4mt) 4 sheave quick-reeve hook block with safety latch

- 75 ton (68.0mt) 5 sheave quick-reeve hook block with safety latch
- 8.5 ton (7.7mt) swivel and non-swivel hook balls with safety latch
- 10 ton (9.1mt) swivel and non-swivel hook balls with safety latch

### Fly — Optional

- 38 ft (11.58m) one piece lattice fly, stowable, offsettable to  $2^{\circ}$ ,  $15^{\circ}$ ,  $30^{\circ}$ , and  $45^{\circ}$ . Maximum tip height is 173 ft (52.9m).
- 38 ft–64 ft (11.58–19.51m) two piece bi-fold lattice fly, stowable, offsettable to  $2^{\circ}$ ,  $15^{\circ}$ ,  $30^{\circ}$ , and  $45^{\circ}$ . Maximum tip height is 199 ft (60.6m).

### Fly Extensions — Optional

- One 16 ft (4.88m) lattice extension, equipped with two 16.5 in (41.9cm) root diameter nylon sheaves, to be mounted between the boom head and fly options. Maximum tip height is 214 ft (65.4m). Minimum of 10,800 lb (4 900kg) of counterweight required.
- Two 16 ft (4.88m) lattice extensions, one equipped with two 16.5 in (41.9cm) root diameter nylon sheaves, to be mounted between the boom head and fly options. Maximum tip height is 230 ft (70.2m). Minimum of 14,400 lb (6 530kg) of counterweight required.

## ■ Upper Operator's Cab and Controls

**Environmental Cab** — Fully enclosed, one person cab of galvaneal steel structure with acoustical insulation.

Equipped with:

- Tinted and tempered glass windows
- Extra-large fixed front window with windshield wiper and washer
- Swing up roof window with windshield wiper
- Sliding left side door with large fixed window
- Sliding rear and right side windows for ventilation
- Six way adjustable, cushioned seat with seat belt and storage compartment
- Diesel fired warm-water heater with air ducts for front windshield defroster and cab floor
- Defroster fan for the front window
- Bubble level
- Circulating fan
- Adjustable sun visor
- LED Dome light
- Cup holder
- Fire extinguisher
- Left side viewing mirror
- Pull-out cabwalk
- Two position travel swing lock
- AM/FM radio

**Air Conditioning — Optional** — Integral with cab heating system utilizing the same ventilation outlets

**Engine Dependent Heater — Optional** — Flameless, warm-water system that does not have a separate fuel tank

**Armrest Controls** – Two dual axis hydraulic joystick controllers or optional single axis hydraulic controllers for:

- Cab heater and A/C controls
- Swing
- Boom hoist
- Main rear winch
- Auxiliary front winch – optional
- Drum rotation indication
- Drum rotation indicator activation switch
- Swing park brake switch
- Winch high/low speed and disable switch(es)
- Warning horn button

**Outrigger Controls** – Hand held control box with umbilical cord gives the operator the freedom to view operation while setting the outriggers.

#### Foot Controls

- Boom telescope
- Swing brake
- Engine throttle

**Right Front Console** – Controls and indicators for:

- Engine ignition
- Engine throttle lock
- Pump enable
- Function disable
- Front windshield wiper and washer
- Cab floodlights
- Warning horn
- Console dimmer switch
- Bubble level
- 12 volt power connection
- Air conditioning – optional
- Boom floodlight – optional
- Rotating beacon or strobe light – optional
- Third wrap selector switch – optional

**Camera Display** – Located on dash console

- Displays right side of upper
- Displays main and auxiliary winches

**Cab Instrumentation** – Ergonomically positioned LCD display, CANBUS instrumentation for crane operation including:

- Tachometer
- Engine water temperature
- Fuel level
- Hydraulic oil temperature
- Stop engine
- Check engine
- Regeneration disabled light (EPA 2013 engine only)
- DPF regeneration light (EPA 2013 engine only)
- High exhaust temperature light (EPA 2013 engine only)
- Malfunction indicator lamp (EPA 2013 engine only)
- Engine air filter high restriction light
- Engine oil pressure
- Swing park brake light
- Battery voltage
- Fuel rate (gal/hr)
- Engine load
- Engine Diagnostics

**Link-Belt Pulse** – The Link-Belt in-house designed, total crane operating system that utilizes the display as a readout and operator interface for the following systems:

- **Rated capacity limiter** – LCD graphic audio – visual warning system integrated into the dash with anti – two block and function limiter. Operating data includes:
  - Crane configuration
  - Boom length and angle
  - Boom head height
  - Allowed load and % of allowed load
  - RCL light bar
  - Boom angle
  - Radius of load
  - Actual load
  - Wind speed
  - Highlighted unit of measurement on working screen
  - Active pin/latch status
  - Telescope operation displayed in real time
  - Third wrap indicator

- Diagnostics
- Operator settable alarms (include):
  - Maximum and minimum boom angles
  - Maximum tip height
  - Maximum boom length
  - Swing left/right positions
  - Operator defined area (imaginary plane)
- **Telematics** – Cellular–based data logging and monitoring system that provides:
  - Location and operational settings
  - Routine maintenance
  - Crane and engine monitoring
  - Diagnostic and fault codes
- **Extend control module (ECM)**
  - Controls the extend modes
  - Diagnostics

**Integrated Third Wrap Indicator – Optional** – Link–Belt Pulse color display visually and audibly warns the operator when the wire rope is on the first/bottom layer and when the wire rope is down to the last three wraps.

**Integrated Third Wrap Function Kickout – Optional** – Link–Belt Pulse color display visually and audibly warns the operator when the wire rope is on the first/bottom layer and provides a function kickout when the wire rope is down to the last three wraps.

**Internal RCL Light Bar** – Visually informs the operator when crane is approaching maximum load capacity with a series of green, yellow, and red lights.

**External RCL Light Bar – Optional** – Visually informs the ground crew when crane is approaching maximum load capacity with a series of green, yellow, and red lights.

## ■ Swing

**Motor/Planetary** – Bi–directional hydraulic swing motor mounted to a planetary reducer for 360° continuous smooth swing at 1.9 rpm.

**Swing Park Brake** – 360°, electric over hydraulic, (spring applied/hydraulic released) multi–disc brake mounted on the speed reducer. Operated by a switch from the operator’s cab.

**Swing Brake** – 360°, foot operated, hydraulic applied disc brake mounted to the speed reducer.

**Swing Lock** – Two–position swing lock (boom over front or rear) operated from the operator’s cab.

**360° Positive Swing Lock – Optional** – Meets New York City requirement.

## ■ Electrical

**Swing Alarm** – Audio warning device signals when the upper is swinging.

#### Lights

- Two LED working lights on front of the cab
- One LED working light on top of the cab – optional
- One amber strobe beacon on top of the cab – optional
- Boom floodlight – Single – optional
- Boom floodlight – Dual – optional
- Boom floodlight – High intensity remote controlled – optional

## Load Hoist System

### Load Hoist Performance

Main (Rear) and Auxiliary (Front) Winches — 3/4 in (19mm) Rope										
Layer	Maximum Line Pull		Normal Line Speed		High Line Speed		Layer		Total	
	lb	kN	ft/min	m/min	ft/min	m/min	ft	m	ft	m
1	16,880	75.09	172	52.4	341	104.0	114	34.7	114	34.7
2	15,519	69.03	187	57.0	371	113.1	124	37.8	238	72.5
3	14,362	63.89	202	61.6	401	122.2	134	40.8	372	113.4
4	13,365	59.45	217	66.1	430	131.1	144	43.9	516	157.3
5	12,497	55.59	232	70.7	460	140.2	154	46.9	670	204.2
6	----	----	----	----	----	----	164	50.0	834	254.2

Wire Rope Application		Diameter		Type	Maximum Permissible Load	
		in	mm		lb	kN
Main (Rear) Winch	Standard	3/4	19	18x19 rotation resistant — right regular lay (Type RB)	12,920	57.47
	Optional	3/4	19	4 strand, low torque, right regular lay (Type GC)	22,400	99.64
	Optional	3/4	19	36x7 rotation resistant — right regular lay (Type ZB)	15,600	69.39
Auxiliary (Front) Winch	Standard	3/4	19	18x19 rotation resistant — right regular lay (Type RB)	12,920	57.47
	Optional	3/4	19	4 strand, low torque, right regular lay (Type GC)	22,400	99.64
	Optional	3/4	19	36x7 rotation resistant — right regular lay (Type ZB)	15,600	69.39

### 2M Main and Optional Auxiliary Winches

- Axial piston, full and half displacement (2—speed) motors driven through planetary reduction unit for positive control under all load conditions.
- Grooved lagging
- Power up/down mode of operation
- Hoist drum cable follower — optional
- Drum rotation indicator
- Drum diameter: 16 in (40.6cm)
- Rope length:
  - Main: 670 ft (204.2m)
  - Auxiliary: 500 ft (152.4m) or 670 ft (204.2m)
- Maximum rope storage: 834 ft (254.2m)
- Terminator style socket and wedge

### Hydraulic System

All circuits of the hydraulic system are pressure compensated.

**Counterbalance Valves** — All hoist motors, boom extend cylinders, and boom hoist cylinders are equipped with counterbalance valves to provide load lowering and to prevent accidental load drop if hydraulic power is suddenly reduced.

**Hydraulic Oil Cooler** — One carrier mounted cooler removes heat from the hydraulic oil. The cooler is mounted in left side access ladder.

**Boom Hoist Float Valves (Optional)** — For transporting the boom over the rear of the crane with a boom dolly. Allows hydraulic oil within the boom hoist cylinder to flow between piston side and case side, allowing the boom to float while on the boom dolly.

**Swing Brake Release** — For transporting the boom over the rear of the crane with a boom dolly. Holds the 360° swing park brake in the released position allowing free rotation of the upper structure.

### Counterweight

**Standard** — Total of 10,800 lb (4.8t) of total counterweight consisting of three, hydraulically removable counterweights. Assembled and disassembled by hydraulic cylinders controlled from the left and right side of the upper structure with capacities for:

- 0 lb (0t) counterweight
- 3,600 lb (1.6t) counterweight
- 7,200 lb (3.2t) counterweight
- 10,800 lb (4.8t) counterweight

**Optional** — 3,600 lb (1.6t) in addition to standard counterweight for a total of 14,400 lb (6.4t) with additional capacities for:

- 14,400 lb (6.4t) counterweight

**Optional** — 7,600 lb (3.4t) in addition to standard counterweight for a total of 18,400 lb (8.2t) with additional capacities for:

- 14,400 lb (6.4t) counterweight
- 18,400 lb (8.2t) counterweight\*

Low speed jobsite travel is offered for these optional counterweight configurations and a boom dolly or boom trailer may be required for on—highway travel.

\* Overall width of the crane increases to 10 ft 5 in (3.2m) for this counterweight configuration

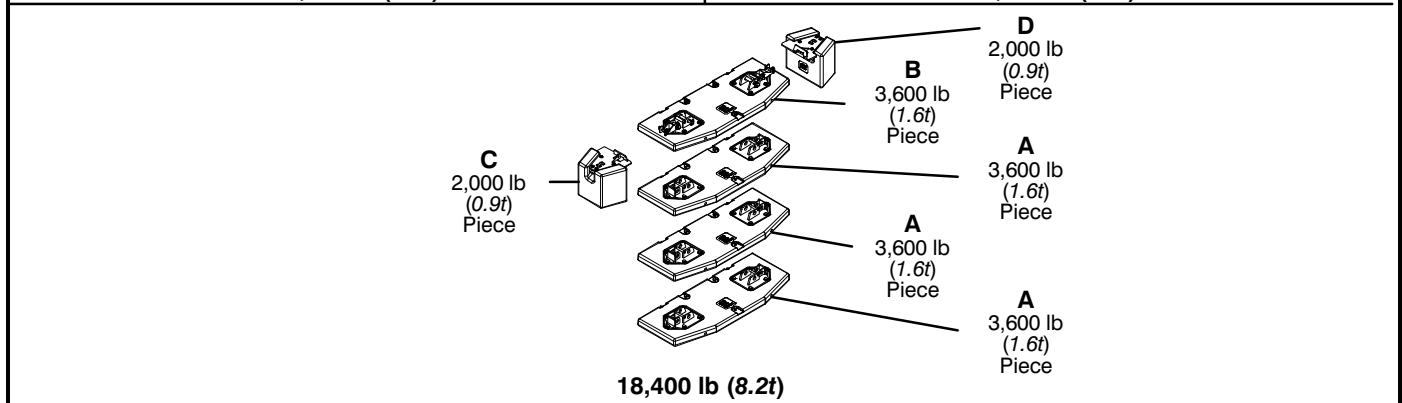
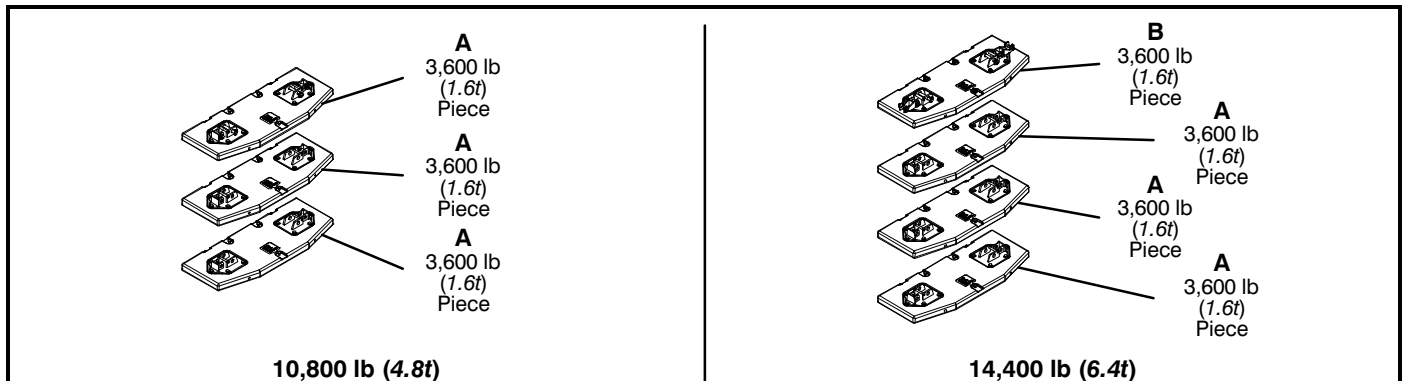

<b>Counterweight Packages</b>			10,800 lb (4.9t) – Standard					
<b>Counterweight Packages</b>			14,400 (6.4t) – Optional					
<b>Counterweight Packages</b>			18,400 (8.2t) – Optional					
<b>Counterweight Pieces</b>			<b>A</b> 3,600 lb (1.6t) Piece	<b>A</b> 3,600 lb (1.6t) Piece	<b>A</b> 3,600 lb (1.6t) Piece	<b>B</b> 3,600 lb (1.6t) Piece	<b>C</b> 2,000 lb (0.9t) Piece	<b>D</b> 2,000 lb (0.9t) Piece
<b>Counterweight Configurations</b>		0 lb (0t)						
	A	3,600 lb (1.6t)	X					
	A,A	7,200 lb (3.2t)	X	X				
	A,A,A	10,800 lb (4.8t)	X	X	X			
	A,A,A,B	14,400 lb (6.4t)	X	X	X	X		
	A,A,A,B,C,D	18,400 lb (8.2t)	X	X	X	X	X	X



# Carrier

## ■ General

- 8 ft 6 in (2.6m) wide
- 23 ft 10 in (7.26m) wheelbase (centerline of first axle to centerline of fourth axle)
- **Frame** — Box-type, torsion resistant, welded construction made of high tensile steel. Equipped with front and rear towing and tie-down lugs, tow connections, and access ladders.

## ■ Outriggers

**Boxes** — Two double box, front and rear welded to the carrier frame

**Beams and Jacks** — Four dual stage beams with Confined Area Lifting Capacities (CALC) provide selectable outrigger extensions of full, intermediate, and retracted positions. Jacks with integral check valves, hydraulically controlled from the operator's cab and on both sides of carrier. A fifth front bumper outrigger, 16 in (40.64cm) diameter, self storing with integral check valves is hydraulically controlled from the operator's cab and at the front bumper of carrier.

### Pontoons

- **Main** — Four lightweight, stow'n go, 23.5" x 27.25" (59.7 x 69.2cm) hexagonal steel pontoons with a contact area of 485 in<sup>2</sup> (3 129cm<sup>2</sup>) can be stored for road travel in either the storage racks on the carrier or under the outrigger boxes
- **Front Bumper** — One, lightweight, self-storing, 16" (40.6cm) diameter steel pontoon with a contact area of 201 in<sup>2</sup> (1 296cm<sup>2</sup>)

### Jack Reaction

- **Main** — 106,000 lb (471.5kN) force and 218 psi (1 503kPa) ground bearing pressure
- **Front Bumper** — 51,000 lb (226.9kN) force and 254 psi (1 751kPa) ground bearing pressure

## ■ Steering and Axles

- Sheppard full integral master gear/slave gear steering system provides hydraulic assisted steering with mechanical link between steering wheel and wheels
- **Drive** — 8 x 4 for on/off—highway travel
- **Axle 1 & 2** — Tandem steered, non-driven
- **Axle 3 & 4** — Tandem non-steered, driven with reduction: 6.35 to 1
- **Inter-Axle Differential Lock** — Traction adding device that locks axle 3 with axle 4. Operated by a switch from the carrier cab.
- **Transverse (Cross-Axle) Differential Locks** — Traction adding device that locks differentials within axles 3 and 4. Operated by a switch from the carrier cab.

## ■ Suspension

**Front** — Raydan Air Link walking beam air suspension

**Rear** — Raydan Air Link walking beam air suspension

- **Axle Lift System — Optional** — Improves rear tire ground clearance when the crane is up on outriggers. The rear tandem axles are raised and lowered with a switch in the carrier cab. The axle lift system can be controlled with a switch on both sides of the carrier.

## ■ Tires and Wheels

**Front** — Four (single) 445/65R22.5 tires on aluminum disc wheels

**Rear** — Four (single) 445/65R22.5 tires on aluminum disc wheels

- Spare tires and wheels — optional
- Tire inflation kit — optional

## ■ Brakes

**Service** — Full air anti-lock (ABS) brakes on all wheel ends. Dual circuit compressed air system with air dryer.

**Parking/Emergency** — Spring loaded type, acting on 3rd and 4th axles automatically apply when air pressure drops below 40 psi (275.8kPa) in both circuits.

## ■ Electrical

**Battery** — Three batteries provide 12 volt starting and operation

### Lights

- Front lighting includes two main daytime running headlights, two high beam lights, two parking/directional indicators, and three cab marker lights.
- Side lighting includes three parking/directional indicators per side.
- Rear lighting includes two parking/directional indicators, two parking/brake lights, two reverse lights, three marker lights, and a license plate light.
- Other equipment includes hazard/warning system, cab light, instrument panel light, and signal horn.
- One amber strobe beacon behind the cab

## ■ Engine

Specification	Cummins ISX12	Cummins QSX15
Emissions Compliance Level:	EPA 2013 <sup>(1)</sup>	Tier 3/ Stage IIIA <sup>(2)</sup>
Maximum Allowable Sulfur Content of Fuel (PPM):	15	5000
Numbers of cylinders:	6	6
Cycle:	4	4
Bore and Stroke: inch ( <i>mm</i> )	5.11 x 5.91 (130x150)	5.39 x 6.65 (137x169)
Piston Displacement: in <sup>3</sup> (L)	729 (11.9)	915 (15.0)
Max. Brake Horsepower: hp (kW)	450 (336) @ 1,800 rpm 414 (309) @ 2,100 rpm	480 (358.8) @ 1,800 rpm 450 (336) @ 2,100 rpm
Peak Torque: ft lb (Nm)	1,550 (2 102) @ 1,200 rpm	1,550 (2 102) @ 1,400 rpm
Alternator: volts – amps	12 – 145	12 – 135
Crankcase Capacity: qt (L)	48 (45.4)	48 (45.4)
<ul style="list-style-type: none"> <li>• Cruise control</li> <li>• Cummins ISX12 – Three stage engine compression brake</li> <li>• Cummins QSX15 – Two stage compression brake</li> <li>• Thermostatically controlled, hydraulically driven radiator fan</li> <li>• 120 volt engine block heater – ISX12</li> <li>• 220 volt engine block heater – QSX15</li> <li>• Engine equipped with on-board diagnostics – ISX</li> <li>• Ether injection system – optional on ISX</li> <li>• Grid heater starting aid standard on QSX</li> </ul> <p><sup>(1)</sup> Can only be sold and/or operated where EPA2013 on-highway emission standards are accepted.</p> <p><sup>(2)</sup> Can only be sold and/or operated where Tier 3/Stage IIIA off-highway emission standards are accepted.</p>		

## ■ Transmission

**Automated** – ZF AS-TRONIC (no clutch pedal) manual transmission with 12 forward gears and 2 reverse gears.

## Carrier Speeds and Gradeability

ZF Astronic		Governed Speed				Gradeability (@ Peak Torque Except Creep @ Idle)		
		EPA 2013		Tier 3/Stage IIIA		% Grade		
Gear	Ratio	mph	km/h	mph	km/h	EPA 2013	Tier 3/ Stage IIIA	
						12th	0.78	53.2
11th	1.00	41.4	66.7	43.5	70.0	3.7	3.9	
10th	1.27	32.7	52.6	34.3	55.3	4.7	5.3	
9th	1.63	25.4	40.9	26.7	43.0	6.1	7.1	
8th	2.10	19.7	31.7	20.7	33.3	7.9	9.4	
7th	2.70	15.3	24.7	16.1	25.9	10.1	12.4	
6th	3.55	11.7	18.8	12.3	19.7	13.3	16.5	
5th	4.57	9.1	14.6	9.5	15.3	17.1	21.4	
4th	5.78	7.2	11.5	7.5	12.1	21.6	27.3	
3rd	7.44	5.6	9.0	5.9	9.4	27.8	35.3	
2nd	9.59	4.3	7.0	4.5	7.3	35.9	45.8	
1st	12.33	3.4	5.4	3.5	5.7	46.1	59.0	
Reverse 1	11.41	3.6	5.8	3.8	6.1	42.7	54.6	
Reverse 2	8.88	4.7	7.5	4.9	7.9	33.2	42.3	
Creep @ idle	2nd	9.59	1.4	2.3	1.5	2.4	33.2	32.4
	1st	12.33	1.1	1.8	1.2	1.9	41.5	41.8
	Reverse 1	11.41	1.2	1.9	1.3	2.0	38.4	38.7
	Reverse 2	8.88	1.6	2.6	1.6	2.6	29.9	30.0

Based on a gross vehicle weight of 95,000 lb (43 091.3kg)

### Fuel Tank

- One 80 gal (302.8L) capacity tank
- One 10 gal (37.8L) capacity diesel exhaust fluid (DEF) plastic tank

### Hydraulic System

All functions are hydraulically powered allowing positive, precise control with independent or simultaneous operation of all functions.

#### Main Pumps

- Three fixed displacement gear pumps with automatic disconnect for the main and auxiliary winches, swing, boom hoist, control circuit, and telescope for use when pick & carry switch is in travel mode.
- One fixed displacement gear pump for steering and the front bumper outrigger.
- Two fixed displacement gear pumps for engine cooling fan and main outriggers. These pumps also provide flow to the winches and boom hoist for “pick & carry” mode. Operated by a switch in the carrier cab.

- Combined pump capacity of 188 gpm (711.7Lpm)

**Hydraulic Reservoir** – 144 gal (545.1L) capacity equipped with sight level gauge. Diffusers built in for deaeration.

**Filtration** – One 10 micron, full flow, return line filter. All oil is filtered prior to return to reservoir. Accessible for easy filter replacement.

### Pump Drive

All pumps are mechanically driven by the diesel engine. Main and auxiliary winches, swing, boom hoist, control circuit, and telescope pumps are mounted to an automatic pump disconnect on the rear of the transmission to aid in cold weather starting as well as to reduce pump wear while traveling.

## ■ Lower Cab and Controls

**Environmental Cab** — Fully enclosed, one person cab of composite structure with acoustical insulation. Equipped with:

- Tinted and tempered glass windows
- Roll down left side window for ventilation
- Windshield wiper and washer
- Six way adjustable and air suspended driver's seat with seat belt
- Two adjustable rear view mirrors
- Engine dependent warm-water heater with air ducts for windshield defroster and cab floor
- Adjustable sun visor
- LED Dome light
- 12 volt connection
- Fire extinguisher

**Air Conditioning** — Integral with cab heating system utilizing the same ventilation outlets

**Overhead Console** — Located above the sun visor

- Document storage unit
- AM/FM Radio
- 12 volt accessory jack (switched)
- 12 volt accessory jack (unswitched)
- Strobe beacon switch

**Camera Display** — Located on dash console

- Displays right side of machine
- Displays rear view

**Cab Instrumentation** — Ergonomically positioned analog instrumentation for driving including:

- Speedometer with odometer, hourmeter, trip odometer, and clock
- Front and rear air pressure with warning indicator
- Engine coolant temperature with warning indicator
- Engine oil pressure with warning indicator
- Voltage indicator with warning indicator
- Fuel level
- Tachometer
- Diesel emission fluid with warning indicator (EPA 2013 engine only)

**Right Side Console** — Controls and indicators for:

- Transmission gear shifting
- Transmission digital readout
- Cruise controls
- Engine compression brake controls
- Rear steer axle lock switch
- Rear axle steering switch

**Dash Mounted Controls For:**

- Carrier lights
- Carrier/upper throttle control
- Engine cooling fan override
- Cab heater/air conditioning
- Console dimmer switch
- Anti-lock brake diagnostic switch
- Diesel particulate filter switch
- Park brake
- Pick & carry switch
- Inter-axle differential lock switch
- Rear axle lift system switch — optional
- Engine ignition

**Dash Mounted Indicator For:**

- Check, stop, and service engine
- Turn signal indication
- Park brake
- Cruise activation
- High beam headlights
- Check anti-lock brake system
- Check anti-lock trailer brake system
- Diesel particulate filter indication (EPA 2013 Engine Only)
- High exhaust temperature indication (EPA 2013 Engine Only)
- Regeneration inhibit (EPA 2013 engine only)
- Malfunction indicator lamp (EPA 2013 engine only)

**Steering Column Controls For:**

- Engine ignition
- Warning horn
- Turn indicators
- High beam headlights
- Steering wheel adjustments
- Intermittent windshield wiper and washer
- Hazard lights

**Foot Controls For:**

- Carrier service brakes
- Engine throttle

## ■ Additional Equipment

**Standard:**

- Aluminum full deck fenders with mud flaps
- Left and right bubble levels
- Air hose connection ports
- Clearance flags

**Optional:**

- Pneumatic and electrical quick disconnect connectors mounted on the rear for trailer or boom dolly brakes and lights
- Left side aluminum storage box
- Rear mounted pintle hook

# Axle Loads

Base crane with full tank of fuel and no counterweight	Gross Vehicle Weight <sup>(1)</sup>		Front Axles		Rear Axles	
	lb	kg	lb	kg	lb	kg
	EPA 2013	75,551	34 269	35,257	15 992	40,294
Tier 3 / Stage IIIA	75,217	34 118	34,955	15 855	40,262	18 263
Driver in carrier cab	250	113	315	143	-65	-29
Rear pintle hook	13	6	-6	-3	19	8
Pneumatic and electrical connectors for trailer or boom dolly	11	5	-2	-1	13	6
Carrier aluminum storage box	60	27	28	13	32	14
Air ride lift system – rear axles	47	21	0	0	47	21
Ether injection	5	2	6	3	-1	-1
Hoist drum follower – main	76	34	-43	-19	119	54
Auxiliary winch with 500 ft (152.4m) of 3/4" (19mm) type "GC" rope	652	296	-238	-108	890	404
Hoist drum follower – auxiliary	76	34	-32	-14	108	49
Substitute 500 ft (152.4m) of rope with 670 ft (204.2m) of rope – auxiliary	213	97	-77	-35	290	132
Remove 670 ft (204.2m) of rope from rear (main) winch	-856	-388	439	199	-1,295	-587
Remove 500 ft (152.4m) of rope from front (auxiliary) winch	-643	-292	233	106	-876	-397
Air conditioner – operator's cab	217	98	-15	-7	232	105
360° mechanical swing lock	140	64	21	9	119	54
3,600 lb (1 635kg) counterweight on upper – 1 piece	3,652	1 657	-1,796	-815	5,448	2 471
7,200 lb (3 265kg) counterweight on upper – 2 pieces	7,304	3 313	-3,593	-1 630	10,897	4 943
10,800 lb (4 900kg) counterweight on upper – 3 pieces	10,956	4 970	-5,389	-2 444	16,345	7 414
14,400 lb (6 530kg) counterweight on upper – 4 pieces	14,608	6 626	-7,185	-3 259	21,793	9 885
Floodlight to the front of boom base section	9	4	10	4	-1	0
Fly mounting brackets to boom base section for fly options	176	80	136	62	40	18
38 ft (11.58m) offsettable fly – stowed	1,671	758	1,758	798	-87	-40
38–64 ft (11.58–19.51m) offsettable fly – stowed	2,413	1 095	2,191	994	222	101
Auxiliary lifting sheave	110	50	217	99	-107	-49
40 ton (36.3mt) 4–sheave hook block at boom head	900	408	1,707	774	-807	-366
60 ton (54.4mt) 4–sheave hook block at boom head	1,109	503	2,103	954	-994	-451
75 ton (68.0mt) 5–sheave hook block at boom head	1,406	638	2,667	1 210	-1,261	-572
8.5 ton (7.7mt) hook ball at boom head	360	163	683	310	-323	-146
10 ton (9.1mt) hook ball at boom head	550	249	1,043	473	-493	-224

Counterweight Load Transfer	Front Axles		Rear Axles	
	lb	kg	lb	kg
Transfer 3,600 lb (1 635kg) counterweight to carrier deck – 1 piece	4,573	2 074.3	-4,573	-2 074.3
Transfer 7,200 lb (3 265kg) counterweight to carrier deck – 2 pieces	9,145	4 148.1	-9,145	-4 148.1
Transfer 10,800 lb (4 900kg) counterweight to carrier deck – 3 pieces	13,718	6 222.4	-13,718	-6 222.4

Axle	Maximum Load @ 65 mph (105km/h)
Front	46,400 lb (21 047kg) – aluminum disc wheels with 445/65R22.5 tires
Rear	51,200 lb (23 224kg) – aluminum disc wheels with 445/65R22.5 tires

<sup>(1)</sup> Adjust gross vehicle weight and axle loading according to component weight. All weights are ±3%.

## Axle Loads with 2–Axle or 3–Axle Boom Dolly

Base crane with full tank of fuel and no counterweight	Gross Vehicle Weight <sup>(1)</sup>		Front Axles		Rear Axles		Dolly Axles	
	lb	kg	lb	kg	lb	kg	lb	kg
	EPA 2013	75,551	34 269	28,854	13 088	33,385	15 143	13,312
Tier 3 / Stage IIIA	75,217	34 118	28,552	12 951	33,353	15 129	13,312	6 038
Nelson 2–axle dolly	6,000	2 721	0	0	0	0	6,000	2 721
Nelson 3–axle dolly	7,160	3 248	0	0	0	0	7,160	3 248
Driver in carrier cab	250	113	315	143	–65	–29	0	0
Rear pintle hook	13	6	–6	–3	19	8	0	0
Pneumatic and electrical connectors for trailer or boom dolly	11	5	–2	–1	13	6	0	0
Carrier aluminum storage box	60	27	28	13	32	14	0	0
Air ride lift system – rear axles	47	21	0	0	47	21	0	0
Ether injection	5	2	6	3	–1	–1	0	0
Hoist drum follower – main	76	34	63	29	13	6	0	0
Auxiliary winch with 500 ft (152.4m) of 3/4" (19mm) type "GC" rope	659	299	418	190	241	109	0	0
Hoist drum follower – auxiliary	76	34	52	24	24	11	0	0
Substitute 500 ft (152.4m) of rope with 670 ft (204.2m) of rope – auxiliary	213	97	134	61	79	36	0	0
Remove 670 ft (204.2m) of rope from rear (main) winch	–856	–388	–669	–303	–187	–85	0	0
Remove 500 ft (152.4m) of rope from front (auxiliary) winch	–643	–292	–406	–184	–237	–108	0	0
Air conditioner – operator's cab	217	98	73	33	144	65	0	0
360° mechanical swing lock	140	64	17	8	123	56	0	0
3,600 lb (1 635kg) counterweight on upper – 1 piece	3,652	1 657	2,776	1 259	876	397	0	0
7,200 lb (3 265kg) counterweight on upper – 2 pieces	7,304	3 313	5,553	2 519	1,751	794	0	0
10,800 lb (4 900kg) counterweight on upper – 3 pieces	10,956	4 970	8,329	3 778	2,627	1 192	0	0
14,400 lb (6 530kg) counterweight on upper – 4 pieces	14,608	6 626	11,106	5 038	3,502	1 589	0	0
Floodlight to the front of boom base section	9	4	1	1	1	1	7	3
Fly mounting brackets to boom base section for fly options	176	80	30	14	30	14	116	53
38 ft (11.58m) offsettable fly – stowed	1,671	758	130	59	131	59	1,410	640
38–64 ft (11.58–19.51m) offsettable fly – stowed	2,413	1 095	302	137	305	138	1,806	819
Two 16 ft (4.88m) lattice inserts (stowed on 3–axle boom dolly)	3,168	1 437	0	0	0	0	3,168	1 437
Auxiliary lifting sheave	110	50	–25	–11	–25	–11	160	73
40 ton (36.3mt) 4–sheave hook block at boom head	900	408	–179	–81	–180	–82	1,259	571
60 ton (54.4mt) 4–sheave hook block at boom head	1,109	503	–220	–100	–222	–101	1,552	704
75 ton (68.0mt) 5–sheave hook block at boom head	1,406	638	–279	–127	–282	–128	1,967	892
8.5 ton (7.7mt) hook ball at boom head	360	163	–72	–33	–72	–33	504	229
10 ton (9.1mt) hook ball at boom head	550	249	–109	–49	–110	–50	770	349

Counterweight Load Transfer	Front Axles		Rear Axles		Dolly Axles	
	lb	kg	lb	kg	lb	kg
Transfer 3,600 lb (1 635kg) counterweight to boom dolly	–2,776	–1 259	–876	–397	3,652	1 657
Transfer 7,200 lb (3 265kg) counterweight to boom dolly	–5,553	–2 519	–1,751	–794	7,304	3 313
Transfer 10,800 lb (4 900kg) counterweight to boom dolly	–8,329	–3 778	–2,627	–1 192	10,956	4 970
Transfer 14,400 lb (6 530kg) counterweight to boom dolly	–11,106	–5 038	–3,502	–1 589	14,608	6 626

Axle	Maximum Load @ 65 mph (105km/h)
Front	46,400 lb (21 047kg) – aluminum disc wheels with 445/65R22.5 tires
Rear	51,200 lb (23 224kg) – aluminum disc wheels with 445/65R22.5 tires

<sup>(1)</sup> Adjust gross vehicle weight and axle loading according to component weight. All weights are ±3%.

# General Dimensions

## EPA 2013

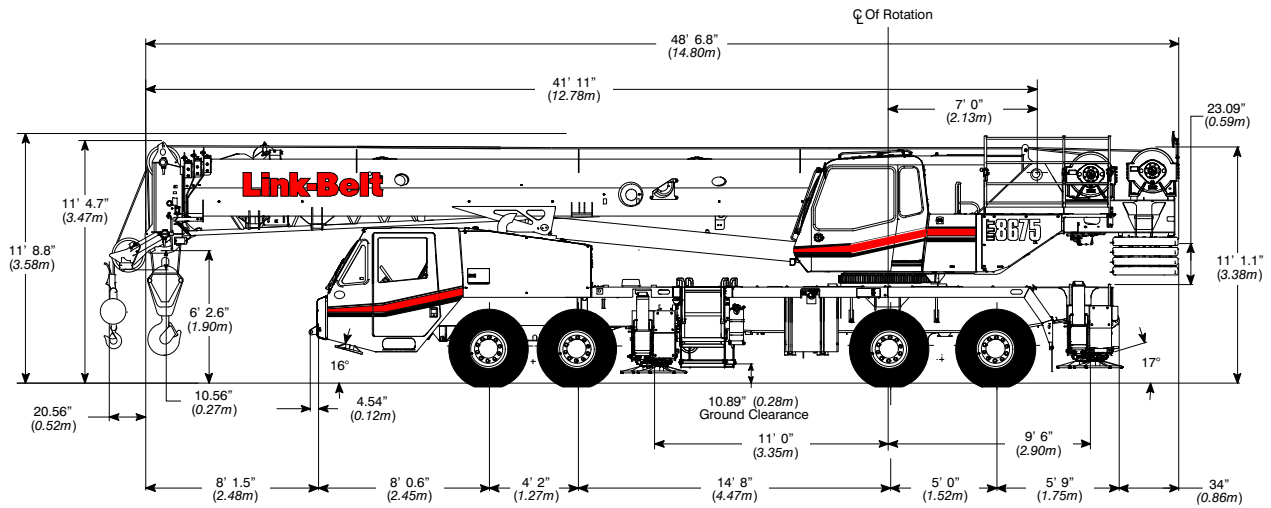

Turning Radius – Front Wheel (8x4) Steering		English	Metric
Wall to wall over carrier		48' 4"	14.7m
Wall to wall over boom		52' 2"	15.9m
Wall to wall over boom attachment		53' 1"	16.2m
Curb to curb		44' 1"	13.4m
Centerline of tire		43' 4"	13.2m
Turning Radius – All Wheel (8x8) Steering		English	Metric
Wall to wall over carrier		32' 10"	10.0m
Wall to wall over boom		37' 8"	11.5m
Wall to wall over boom attachment		38' 1"	11.6m
Curb to curb		28' 4"	8.6m
Centerline of tire		27' 7"	8.4m
Tail Swing		English	Metric
With counterweight		13' 9"	4.2m
Overall Width		English	Metric
With up to 14,400 lb (6 530kg) counterweight		8' 6"	2.6m
With 18,400 lb (8 345kg) counterweight		10' 4"	3.1m

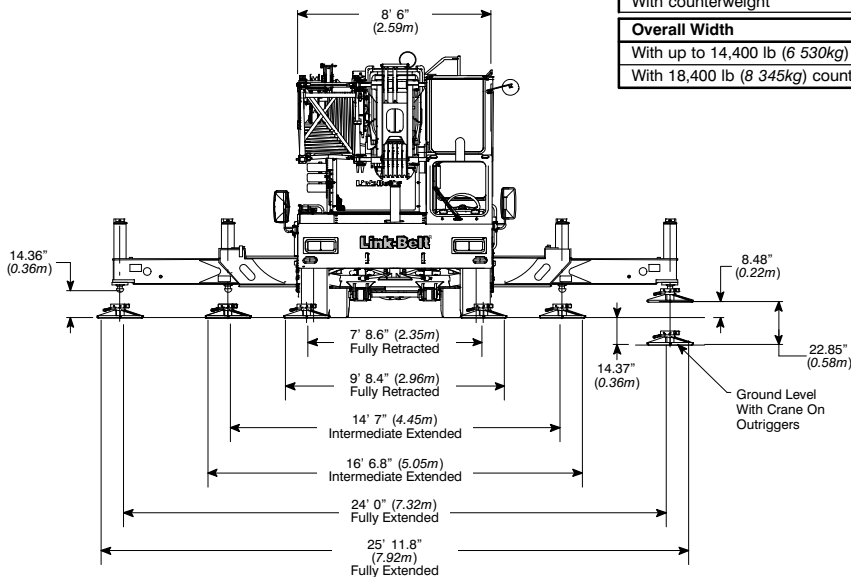

Not To Scale

# General Dimensions

## Tier 3 / Stage IIIA

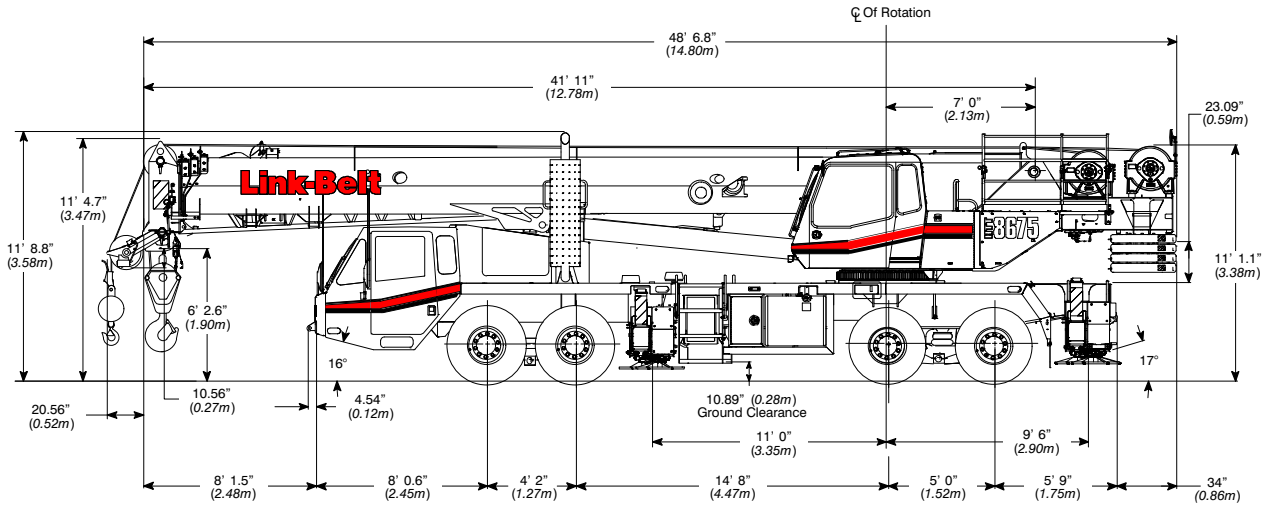

Turning Radius – Front Wheel (8x4) Steering		
	English	Metric
Wall to wall over carrier	48' 4"	14.7m
Wall to wall over boom	52' 2"	15.9m
Wall to wall over boom attachment	53' 1"	16.2m
Curb to curb	44' 1"	13.4m
Centerline of tire	43' 4"	13.2m
Turning Radius – All Wheel (8x8) Steering		
	English	Metric
Wall to wall over carrier	32' 10"	10.0m
Wall to wall over boom	37' 8"	11.5m
Wall to wall over boom attachment	38' 1"	11.6m
Curb to curb	28' 4"	8.6m
Centerline of tire	27' 7"	8.4m
Tail Swing		
	English	Metric
With counterweight	13' 9"	4.2m
Overall Width		
	English	Metric
With up to 14,400 lb (6 530kg) counterweight	8' 6"	2.6m
With 18,400 lb (8 345kg) counterweight	10' 4"	3.1m

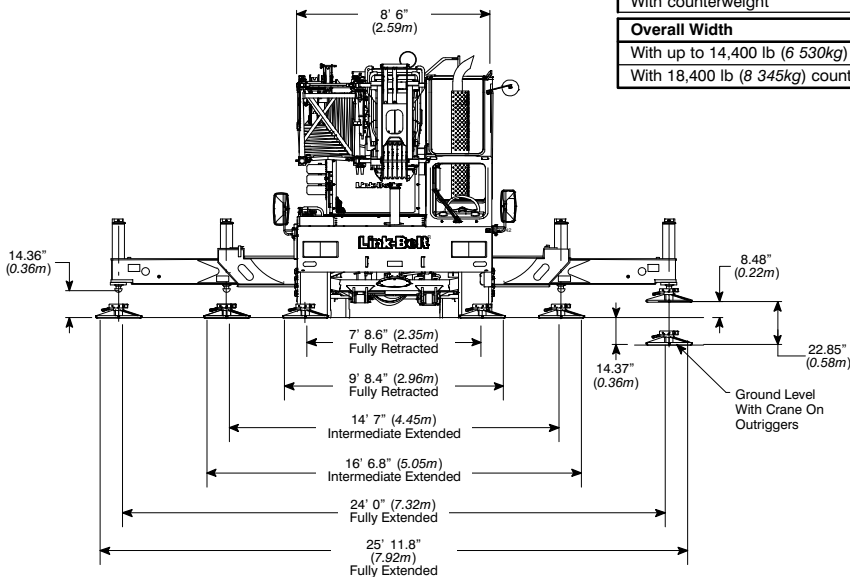

Not To Scale



# Working Range Diagram

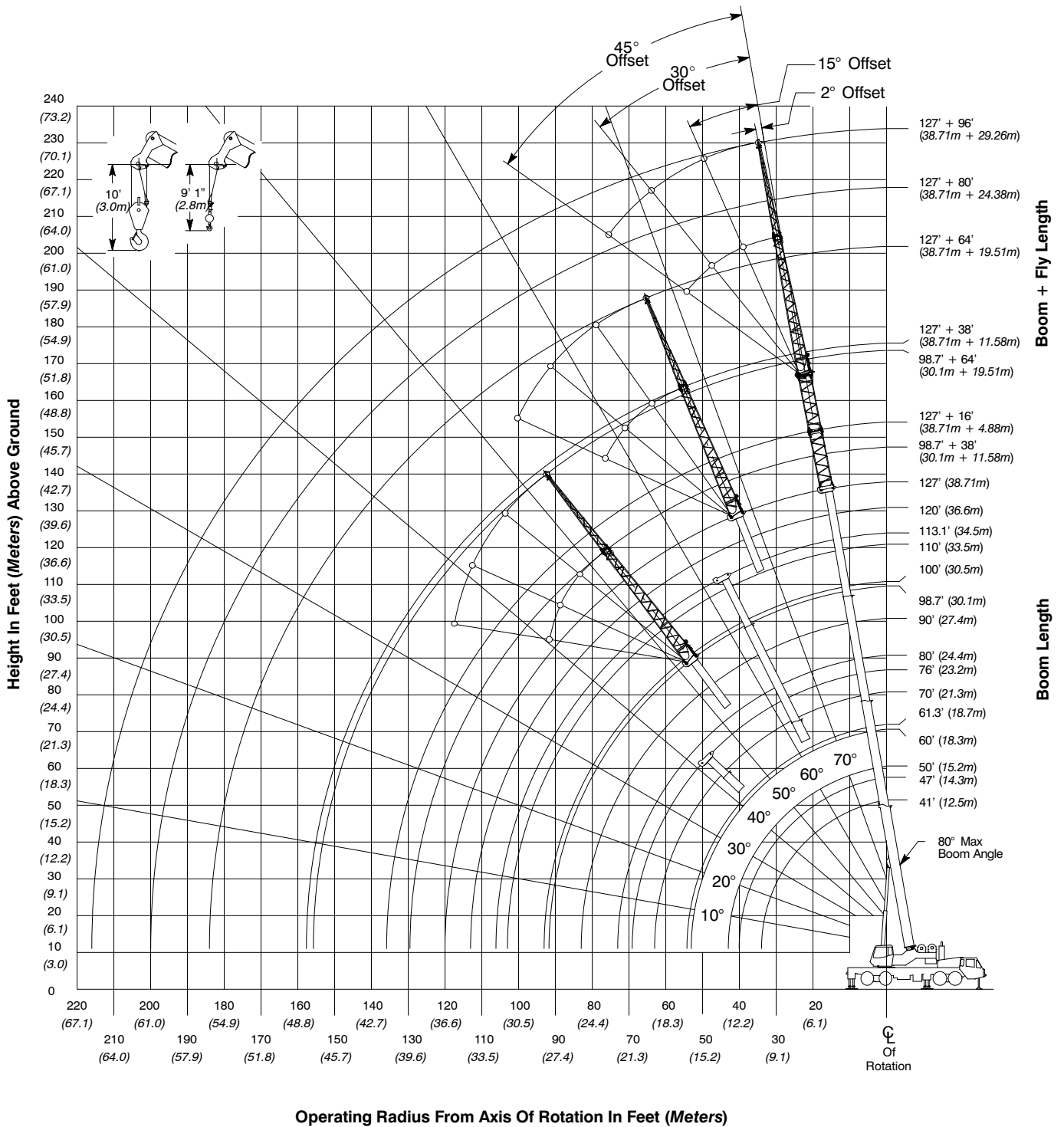

# Boom Extend Modes

Boom Length		Section Length		
ft	m	T3	T2	T1
50	15.2	32%		
60	18.3	68%		
70	21.3	100%	4%	
80	24.4	100%	39%	
90	27.4	100%	74%	
100	30.5	100%	100%	8%
110	33.5	100%	100%	42%
120	36.6	100%	100%	76%
127	38.71	100%	100%	100%

EM  
1

41' (12.5m)  
Extend  
127' (38.71m)

Boom Length		Section Length		
ft	m	T3	T2	T1
50	15.2	32%		
60	18.3	50%	18%	
70	21.3	50%	53%	
80	24.4	50%	87%	
90	27.4	50%	100%	22%
100	30.5	50%	100%	56%
113.1	34.5	50%	100%	100%

EM  
2

41' (12.5m)  
Extend  
113.1' (34.47m)

Boom Length		Section Length		
ft	m	T3	T2	T1
50	15.2	32%		
60	18.3	50%	18%	
70	21.3	50%	50%	3%
80	24.4	50%	50%	37%
90	27.4	50%	50%	71%
98.7	30.1	50%	50%	100%

EM  
3

41' (12.5m)  
Extend  
98.7' (30.1m)

Boom Length		Section Length		
ft	m	T3	T2	T1
47	14.3	22%		
61.3	18.7	22%	50%	
76	23.2	22%	50%	50%

EM  
4

41' (12.50m)  
Extend  
76.0' (23.16m)

# Main Boom Lift Capacity Charts – Standard

0 lb Counterweight – Fully Extended Outriggers – 360° Rotation (All Capacities Are Listed In Pounds)												
Radius (ft)	Boom Length (ft)										Radius (ft)	
	41	50	60	70	80	90	100	110	120	127		
10	124,900	110,700	106,900	74,400								10
12	102,600	103,900	104,800	81,000	62,800							12
15	79,900	81,300	82,500	77,400	62,800	61,400						15
20	57,100	59,100	59,800	60,700	60,400	57,100	47,900	29,100				20
25	43,300	45,300	46,400	46,900	46,700	46,500	42,500	32,800	25,500	22,600		25
30	30,600	33,100	34,600	34,800	35,100	34,300	34,800	32,100	25,500	22,600		30
35		24,600	26,100	26,300	27,400	27,700	26,400	26,600	25,500	22,600		35
40		18,600	20,200	21,100	21,400	21,600	21,700	21,400	21,100	20,900		40
45			16,000	16,900	17,200	17,400	17,400	17,100	16,900	16,700		45
50			12,800	13,800	14,100	14,200	14,300	14,000	13,700	13,600		50
55				11,400	11,700	11,900	12,000	11,700	11,500	11,300		55
60				9,500	9,800	10,000	10,100	9,800	9,600	9,500		60
65				6,400	8,300	8,500	8,500	8,300	8,000	7,900		65
70					6,900	7,200	7,200	7,000	6,800	6,600		70
75						6,100	6,200	5,900	5,700	5,600		75
80						5,100	5,200	5,000	4,800	4,700		80
85							4,400	4,200	4,000	3,900		85
90							3,700	3,500	3,300	3,200		90
95								2,900	2,700	2,600		95
100								2,300	2,200	2,100		100
105								1,000	1,700	1,600		105
110									1,300	1,200		110
115										800		115

This information is not for crane operation. Operator must refer to the in-cab information for crane operation. Rated lifting capacities shown on fully extended outriggers do not exceed 85% of the tipping loads and on tires do not exceed 75% of the tipping loads.

**0 lb Counterweight — On Tires — Stationary — Boom Centered Over Rear**  
(All Capacities Are Listed In Pounds)

Radius (ft)	Boom Length (ft)						Radius (ft)
	41	50	60	70	80	90	
10	25,700						10
12	23,100	24,000	24,600				12
15	19,700	20,700	21,500	20,300			15
20	14,200	15,900	17,200	17,800	16,600		20
25	9,000	10,700	11,900	12,700	12,900	13,000	25
30	5,600	7,300	8,500	9,200	9,500	9,700	30
35		4,900	6,100	6,800	7,100	7,300	35
40		3,100	4,300	5,000	5,300	5,500	40
45			2,900	3,700	4,000	4,200	45
50			1,900	2,600	2,900	3,100	50
55				1,800	2,000	2,200	55
60				1,000	1,300	1,500	60

**0 lb Counterweight — On Tires — Pick & Carry (1 mph) — Boom Centered Over Rear**  
(All Capacities Are Listed In Pounds)

Radius (ft)	Boom Length (ft)						Radius (ft)
	41	50	60	70	80	90	
10	15,000						10
12	13,100	14,000	14,700				12
15	10,700	11,800	12,500	12,900			15
20	7,600	8,700	9,500	10,100	10,200		20
25	5,100	6,400	7,200	7,800	8,000	8,200	25
30	3,200	4,500	5,400	6,100	6,300	6,500	30
35		3,000	4,000	4,600	4,900	5,100	35
40		1,800	2,800	3,500	3,700	3,900	40
45			1,800	2,500	2,700	2,900	45
50				1,700	1,900	2,100	50
55					1,200	1,400	55

This information is not for crane operation. Operator must refer to the in-cab information for crane operation. Rated lifting capacities shown on fully extended outriggers do not exceed 85% of the tipping loads and on tires do not exceed 75% of the tipping loads.

<b>10,800 lb Counterweight — Fully Extended Outriggers — 360° Rotation</b> (All Capacities Are Listed In Pounds)											
Radius (ft)	Boom Length (ft)										Radius (ft)
	41	50	60	70	80	90	100	110	120	127	
10	137,100	110,700	106,900	74,400							10
12	113,100	105,000	106,900	81,000	62,800						12
15	88,500	89,900	90,900	77,400	62,800	61,400					15
20	63,600	65,500	66,100	66,000	62,800	57,100	47,900	29,100			20
25	48,500	50,400	51,400	52,000	51,700	49,900	42,500	32,800	25,500	22,600	25
30	38,300	40,300	41,400	41,900	41,700	41,600	38,100	32,100	25,500	22,600	30
35		32,700	33,900	34,400	34,100	33,900	33,800	29,200	25,500	22,600	35
40		25,800	27,400	27,600	27,900	27,800	27,600	26,700	25,000	22,600	40
45			22,400	22,700	23,200	23,100	22,800	22,500	23,200	22,600	45
50			18,600	19,600	19,900	20,100	19,700	19,800	19,600	19,500	50
55				16,600	16,900	17,000	17,100	16,800	16,600	16,400	55
60				14,100	14,400	14,600	14,600	14,400	14,100	14,000	60
65				10,600	12,500	12,700	12,700	12,500	12,300	12,100	65
70					10,800	11,100	11,100	10,800	10,600	10,500	70
75						9,600	9,700	9,500	9,300	9,100	75
80						8,400	8,500	8,300	8,100	8,000	80
85							7,500	7,300	7,100	7,000	85
90							6,600	6,400	6,200	6,100	90
95								5,600	5,400	5,300	95
100								4,900	4,700	4,600	100
105								3,400	4,100	4,000	105
110									3,500	3,400	110
115										2,900	115

This information is not for crane operation. Operator must refer to the in-cab information for crane operation. Rated lifting capacities shown on fully extended outriggers do not exceed 85% of the tipping loads and on tires do not exceed 75% of the tipping loads.

<b>10,800 lb Counterweight – On Tires – Stationary – Boom Centered Over Rear</b> (All Capacities Are Listed In Pounds)							
Radius (ft)	Boom Length (ft)						Radius (ft)
	41	50	60	70	80	90	
10	25,700						10
12	23,100	23,900	24,500				12
15	19,700	20,700	21,400	21,800			15
20	15,300	16,500	17,200	17,800	17,900		20
25	12,000	13,200	14,100	14,600	14,800	13,900	25
30	9,400	10,700	11,600	12,200	12,400	12,600	30
35		8,500	9,600	10,200	10,400	10,600	35
40		6,300	7,400	8,200	8,500	8,700	40
45			5,700	6,500	6,700	6,900	45
50			4,400	5,100	5,400	5,600	50
55				4,000	4,300	4,500	55
60				3,100	3,400	3,600	60
65					2,600	2,800	65
70					1,900	2,100	70
75						1,600	75
80						1,100	80

<b>10,800 lb Counterweight – On Tires – Pick &amp; Carry (1 mph) – Boom Centered Over Rear</b> (All Capacities Are Listed In Pounds)							
Radius (ft)	Boom Length (ft)						Radius (ft)
	41	50	60	70	80	90	
10	15,400						10
12	12,900	14,100	15,700				12
15	10,700	11,700	12,300	12,500			15
20	7,600	8,700	9,500	10,000	10,200		20
25	5,100	6,400	7,200	7,800	8,000	8,200	25
30	3,200	4,500	5,500	6,100	6,300	6,500	30
35		3,000	4,000	4,600	4,900	5,100	35
40		1,800	2,800	3,500	3,700	3,900	40
45			1,800	2,500	2,700	2,900	45
50			1,000	1,700	1,900	2,100	50
55					1,200	1,400	55

This information is not for crane operation. Operator must refer to the in-cab information for crane operation. Rated lifting capacities shown on fully extended outriggers do not exceed 85% of the tipping loads and on tires do not exceed 75% of the tipping loads.

# Main Boom Lift Capacity Charts – Optional

14,400 lb Counterweight – Fully Extended Outriggers – 360° Rotation (All Capacities Are Listed In Pounds)												
Radius (ft)	Boom Length (ft)										Radius (ft)	
	41	50	60	70	80	90	100	110	120	127		
9	150,000											9
10	140,500	110,700	106,900	74,400								10
12	116,600	105,000	106,900	81,000	62,800							12
15	91,300	92,600	93,700	77,400	62,800	61,400						15
20	65,700	67,600	68,300	68,100	62,800	57,100	47,900	29,100				20
25	50,200	52,100	52,800	53,700	53,400	49,900	42,500	32,800	25,500	22,600		25
30	39,700	41,700	42,800	43,300	43,100	43,000	38,100	32,100	25,500	22,600		30
35		34,300	35,400	35,900	35,800	35,700	34,300	29,200	25,500	22,600		35
40		28,000	29,500	29,700	29,500	29,300	29,100	26,700	25,000	22,600		40
45			24,300	24,600	24,900	24,900	24,700	24,400	23,200	22,600		45
50			20,300	20,600	21,500	21,200	20,700	20,900	21,300	21,000		50
55				18,100	18,400	18,600	18,200	18,400	18,200	18,000		55
60				15,600	15,900	16,200	16,200	15,900	15,700	15,500		60
65				12,000	13,800	14,000	14,100	13,800	13,600	13,400		65
70					12,100	12,300	12,400	12,100	11,900	11,800		70
75						10,800	10,900	10,700	10,400	10,300		75
80						9,500	9,600	9,400	9,200	9,100		80
85							8,500	8,300	8,100	8,000		85
90							7,500	7,300	7,200	7,000		90
95								6,500	6,300	6,200		95
100								5,700	5,600	5,500		100
105								4,200	4,900	4,800		105
110									4,300	4,200		110
115										3,700		115

This information is not for crane operation. Operator must refer to the in-cab information for crane operation. Rated lifting capacities shown on fully extended outriggers do not exceed 85% of the tipping loads and on tires do not exceed 75% of the tipping loads.

<b>14,400 lb Counterweight – On Tires – Stationary – Boom Centered Over Rear</b> (All Capacities Are Listed In Pounds)							
Radius (ft)	Boom Length (ft)						Radius (ft)
	41	50	60	70	80	90	
10	25,500						10
12	23,000	23,800	24,300				12
15	19,700	20,700	21,400	21,800			15
20	15,300	16,400	17,200	17,700	17,900		20
25	12,000	13,200	14,100	14,600	14,800	14,900	25
30	9,400	10,700	11,600	12,200	12,400	12,600	30
35		8,600	9,600	10,200	10,400	10,600	35
40		6,800	7,900	8,500	8,800	9,000	40
45			6,500	7,100	7,400	7,600	45
50			5,200	5,900	6,200	6,400	50
55				4,800	5,000	5,200	55
60				3,800	4,000	4,200	60
65					3,200	3,400	65
70					2,500	2,700	70
75						2,100	75
80						1,600	80

<b>14,400 lb Counterweight – On Tires – Pick &amp; Carry (1 mph) – Boom Centered Over Rear</b> (All Capacities Are Listed In Pounds)							
Radius (ft)	Boom Length (ft)						Radius (ft)
	41	50	60	70	80	90	
10	15,200						10
12	13,300	14,300	15,000				12
15	10,600	12,100	12,900	13,400			15
20	7,600	8,700	9,500	9,900	9,900		20
25	5,100	6,400	7,200	7,800	8,000	8,100	25
30	3,200	4,500	5,500	6,100	6,300	6,400	30
35		3,000	4,000	4,700	4,900	5,100	35
40		1,800	2,800	3,500	3,700	3,900	40
45			1,800	2,500	2,700	2,900	45
50			1,000	1,700	1,900	2,100	50
55					1,200	1,400	55

This information is not for crane operation. Operator must refer to the in-cab information for crane operation. Rated lifting capacities shown on fully extended outriggers do not exceed 85% of the tipping loads and on tires do not exceed 75% of the tipping loads.



<b>18,400 lb Counterweight – Fully Extended Outriggers – 360° Rotation</b> (All Capacities Are Listed In Pounds)												
Radius (ft)	Boom Length (ft)										Radius (ft)	
	41	50	60	70	80	90	100	110	120	127		
9	150,000											9
10	140,500	110,700	106,900	74,400								10
12	120,500	105,000	106,900	81,000	62,800							12
15	94,400	95,800	96,800	77,400	62,800	61,400						15
20	68,000	69,900	70,600	70,400	62,800	57,100	47,900	29,100				20
25	52,000	54,000	54,700	54,900	55,300	49,900	42,500	32,800	25,500	22,600		25
30	41,300	43,300	44,400	44,900	44,700	44,100	38,100	32,100	25,500	22,600		30
35		35,600	36,700	37,300	37,100	37,000	34,300	29,200	25,500	22,600		35
40		29,800	31,000	31,500	31,300	31,200	31,100	26,700	25,000	22,600		40
45			26,300	26,600	26,300	26,100	26,600	24,500	23,200	22,600		45
50			22,100	22,400	22,800	22,700	22,500	22,300	21,600	21,000		50
55				19,100	20,000	19,600	19,300	19,400	19,800	19,400		55
60				17,000	17,400	17,600	16,900	17,400	17,200	17,000		60
65				13,400	15,200	15,400	15,500	15,200	15,000	14,900		65
70					13,300	13,600	13,600	13,400	13,200	13,100		70
75						12,100	12,200	11,900	11,700	11,600		75
80						10,700	10,800	10,600	10,400	10,300		80
85							9,600	9,400	9,200	9,100		85
90							8,600	8,400	8,200	8,100		90
95								7,500	7,300	7,200		95
100								6,700	6,500	6,400		100
105								5,100	5,800	5,700		105
110									5,100	5,000		110
115										4,500		115

This information is not for crane operation. Operator must refer to the in-cab information for crane operation. Rated lifting capacities shown on fully extended outriggers do not exceed 85% of the tipping loads and on tires do not exceed 75% of the tipping loads.

<b>18,400 lb Counterweight – On Tires – Stationary – Boom Centered Over Rear</b> (All Capacities Are Listed In Pounds)							
Radius (ft)	Boom Length (ft)						Radius (ft)
	41	50	60	70	80	90	
10	25,900						10
12	22,200	22,700	23,500				12
15	19,100	20,100	20,600	20,900			15
20	14,800	15,900	16,700	17,200	17,300		20
25	11,600	12,800	13,600	14,200	14,300	14,500	25
30	9,000	10,300	11,200	11,800	12,000	12,200	30
35		8,200	9,200	9,800	10,100	10,200	35
40		6,500	7,600	8,200	8,400	8,600	40
45			6,200	6,800	7,100	7,300	45
50			5,000	5,700	5,900	6,100	50
55				4,700	4,900	5,100	55
60				3,800	4,100	4,300	60
65					3,300	3,500	65
70					2,700	2,900	70
75						2,300	75
80						1,700	80

<b>18,400 lb Counterweight – On Tires – Pick &amp; Carry (1 mph) – Boom Centered Over Rear</b> (All Capacities Are Listed In Pounds)							
Radius (ft)	Boom Length (ft)						Radius (ft)
	41	50	60	70	80	90	
10	14,400						10
12	12,600	13,500	14,200				12
15	10,200	11,300	12,100	12,600			15
20	7,000	8,400	9,200	9,700	10,000		20
25	4,700	5,900	6,700	7,300	7,700	8,000	25
30	2,800	4,100	5,100	5,700	5,800	6,000	30
35		2,700	3,700	4,300	4,500	4,700	35
40		1,500	2,500	3,200	3,400	3,600	40
45			1,500	2,200	2,400	2,600	45
50				1,400	1,600	1,800	50

This information is not for crane operation. Operator must refer to the in-cab information for crane operation. Rated lifting capacities shown on fully extended outriggers do not exceed 85% of the tipping loads and on tires do not exceed 75% of the tipping loads.

## Fly Attachment Lift Capacity Charts – Optional

0 lb Counterweight – Fully Extended Outriggers – 360° Rotation (All Capacities Are Listed In Pounds)					
98.7 ft Main Boom Length – 38 ft Offset Fly Length					
Radius (ft)	2° Fly Offset	15° Fly Offset	30° Fly Offset	45° Fly Offset	Radius (ft)
30	16,200				30
35	15,600				35
40	14,900	12,500			40
45	14,300	12,000	10,100		45
50	13,600	11,500	9,800		50
55	11,900	11,100	9,500	8,600	55
60	9,900	10,700	9,300	8,400	60
65	8,300	9,100	9,000	8,300	65
70	7,000	7,700	8,400	8,100	70
75	5,900	6,600	7,200	7,700	75
80	5,000	5,500	6,100	6,500	80
85	4,200	4,700	5,200	5,500	85
90	3,500	3,900	4,300	4,600	90
95	2,900	3,300	3,600	3,800	95
100	2,300	2,700	3,000	3,100	100
105	1,900	2,100	2,400	2,500	105
110	1,400	1,700	1,900		110
115	1,000	1,200	1,400		115

This information is not for crane operation. Operator must refer to the in-cab information for crane operation. Rated lifting capacities shown on fully extended outriggers do not exceed 85% of the tipping loads and on tires do not exceed 75% of the tipping loads.

0 lb Counterweight – Fully Extended Outriggers – 360° Rotation (All Capacities Are Listed In Pounds)					
127 ft Main Boom Length – 38 ft Offset Fly Length					
Radius (ft)	2° Fly Offset	15° Fly Offset	30° Fly Offset	45° Fly Offset	Radius (ft)
35	10,900				35
40	10,900				40
45	10,900	10,400			45
50	10,900	10,300			50
55	10,900	10,100	9,100		55
60	10,200	9,900	8,900		60
65	8,600	9,400	8,700	8,100	65
70	7,300	8,000	8,600	8,000	70
75	6,200	6,800	7,500	7,900	75
80	5,200	5,800	6,400	6,900	80
85	4,400	5,000	5,500	5,900	85
90	3,700	4,200	4,700	5,000	90
95	3,100	3,500	4,000	4,300	95
100	2,600	3,000	3,300	3,600	100
105	2,100	2,400	2,800	3,000	105
110	1,600	2,000	2,300	2,500	110
115	1,200	1,500	1,800	2,000	115
120		1,100	1,400	1,500	120
125			1,000	1,100	125

This information is not for crane operation. Operator must refer to the in-cab information for crane operation. Rated lifting capacities shown on fully extended outriggers do not exceed 85% of the tipping loads and on tires do not exceed 75% of the tipping loads.

10,800 lb Counterweight – Fully Extended Outriggers – 360° Rotation (All Capacities Are Listed In Pounds)					
98.7 ft Main Boom Length 2° Fly Offset			98.7 ft Main Boom Length 15° Fly Offset		
Radius (ft)	Fly Length (ft)		Radius (ft)	Fly Length (ft)	
	38	64		38	64
30	16,200		30		
35	15,600	10,300	35		
40	14,900	9,900	40	12,500	
45	14,300	9,400	45	12,000	
50	13,600	9,000	50	11,500	7,400
55	13,000	8,500	55	11,100	7,000
60	12,500	8,100	60	10,700	6,700
65	11,900	7,700	65	10,300	6,400
70	10,900	7,300	70	10,000	6,200
75	9,500	7,000	75	9,700	5,900
80	8,300	6,700	80	8,800	5,700
85	7,300	6,400	85	7,800	5,500
90	6,400	6,100	90	6,800	5,300
95	5,600	5,800	95	6,000	5,100
100	4,900	5,600	100	5,200	5,000
105	4,300	5,100	105	4,600	4,800
110	3,700	4,500	110	4,000	4,700
115	3,200	4,000	115	3,400	4,500
120	2,800	3,600	120	2,900	4,000
125	2,300	3,100	125	2,400	3,500
130		2,700	130		3,100
135		2,400	135		2,700
140		2,100	140		2,300
145		1,800	145		2,000
150		1,500	150		1,600
155		1,200	155		

This information is not for crane operation. Operator must refer to the in-cab information for crane operation. Rated lifting capacities shown on fully extended outriggers do not exceed 85% of the tipping loads and on tires do not exceed 75% of the tipping loads.

10,800 lb Counterweight – Fully Extended Outriggers – 360° Rotation (All Capacities Are Listed In Pounds)					
98.7 ft Main Boom Length 30° Fly Offset			98.7 ft Main Boom Length 45° Fly Offset		
Radius (ft)	Fly Length (ft)		Radius (ft)	Fly Length (ft)	
	38	64		38	64
45	10,100		45		
50	9,800		50		
55	9,500		55	8,600	
60	9,300		60	8,400	
65	9,000	5,400	65	8,300	
70	8,800	5,200	70	8,100	
75	8,600	5,100	75	8,000	
80	8,500	4,900	80	7,900	4,400
85	8,200	4,800	85	7,800	4,300
90	7,200	4,700	90	7,500	4,300
95	6,300	4,600	95	6,500	4,200
100	5,500	4,500	100	5,700	4,200
105	4,800	4,400	105	4,900	4,100
110	4,200	4,300	110		4,100
115	3,600	4,200	115		4,100
120		4,200	120		4,100
125		3,900	125		4,100
130		3,400	130		3,500
135		2,900	135		3,000
140		2,500	140		
145		2,100	145		

This information is not for crane operation. Operator must refer to the in-cab information for crane operation. Rated lifting capacities shown on fully extended outriggers do not exceed 85% of the tipping loads and on tires do not exceed 75% of the tipping loads.

10,800 lb Counterweight – Fully Extended Outriggers – 360° Rotation (All Capacities Are Listed In Pounds)							
127 ft Main Boom Length 2° Fly Offset				127 ft Main Boom Length 15° Fly Offset			
Radius (ft)	Fly Length (ft)			Radius (ft)	Fly Length (ft)		
	38	64	80		38	64	80
35	10,900			35			
40	10,900			40			
45	10,900	7,300		45	10,400		
50	10,900	7,300	5,800	50	10,300		
55	10,900	7,200	5,800	55	10,100		
60	10,900	7,100	5,800	60	9,900		
65	10,700	6,900	5,800	65	9,700	6,100	5,600
70	10,500	6,800	5,800	70	9,500	6,000	5,300
75	9,700	6,600	5,800	75	9,300	5,800	5,000
80	8,500	6,500	5,500	80	9,000	5,600	4,700
85	7,500	6,300	5,200	85	8,000	5,500	4,400
90	6,600	6,100	4,900	90	7,100	5,300	4,200
95	5,800	5,900	4,600	95	6,200	5,200	4,000
100	5,100	5,700	4,400	100	5,500	5,100	3,800
105	4,500	5,100	4,200	105	4,800	4,900	3,600
110	3,900	4,500	4,000	110	4,200	4,700	3,500
115	3,400	4,000	3,800	115	3,700	4,500	3,300
120	3,000	3,500	3,400	120	3,200	4,000	3,200
125	2,500	3,100	2,900	125	2,800	3,600	3,000
130	2,200	2,700	2,500	130	2,400	3,100	2,900
135	1,800	2,300	2,200	135	2,000	2,700	2,600
140	1,500	2,000	1,900	140	1,600	2,400	2,200
145	1,200	1,700	1,500	145	1,300	2,000	1,900
150		1,400	1,300	150	1,000	1,700	1,600
155		1,200	1,000	155		1,400	1,300
160				160		1,200	1,000

This information is not for crane operation. Operator must refer to the in-cab information for crane operation. Rated lifting capacities shown on fully extended outriggers do not exceed 85% of the tipping loads and on tires do not exceed 75% of the tipping loads.

10,800 lb Counterweight – Fully Extended Outriggers – 360° Rotation (All Capacities Are Listed In Pounds)							
127 ft Main Boom Length 30° Fly Offset				127 ft Main Boom Length 45° Fly Offset			
Radius (ft)	Fly Length (ft)			Radius (ft)	Fly Length (ft)		
	38	64	80		38	64	80
55	9,100			55			
60	8,900			60			
65	8,700			65	8,100		
70	8,600			70	8,000		
75	8,500			75	7,900		
80	8,300	4,900	3,900	80	7,700		
85	8,000	4,800	3,700	85	7,700		
90	7,500	4,700	3,500	90	7,400	4,200	3,100
95	6,700	4,600	3,400	95	7,000	4,200	2,900
100	5,900	4,500	3,200	100	6,100	4,100	2,800
105	5,200	4,400	3,100	105	5,400	4,100	2,700
110	4,500	4,300	2,900	110	4,700	4,100	2,600
115	4,000	4,200	2,800	115	4,100	4,000	2,500
120	3,500	4,000	2,700	120	3,600	3,900	2,500
125	3,000	3,900	2,600	125	3,100	3,800	2,400
130	2,500	3,600	2,500	130		3,600	2,300
135	2,100	3,100	2,500	135		3,400	2,300
140	1,700	2,700	2,400	140		2,900	2,200
145	1,400	2,300	2,300	145		2,500	2,200
150		2,000	1,900	150		2,100	2,100
155		1,700	1,600	155		1,700	1,800
160		1,300	1,300	160		1,400	1,400
165		1,000	1,000	165			1,100

This information is not for crane operation. Operator must refer to the in-cab information for crane operation. Rated lifting capacities shown on fully extended outriggers do not exceed 85% of the tipping loads and on tires do not exceed 75% of the tipping loads.



14,400 lb Counterweight – Fully Extended Outriggers – 360° Rotation (All Capacities Are Listed In Pounds)					
98.7 ft Main Boom Length 2° Fly Offset			98.7 ft Main Boom Length 15° Fly Offset		
Radius (ft)	Fly Length (ft)		Radius (ft)	Fly Length (ft)	
	38	64		38	64
30	16,200		30		
35	15,600	10,300	35		
40	14,900	9,900	40	12,500	
45	14,300	9,400	45	12,000	
50	13,600	9,000	50	11,500	7,400
55	13,000	8,500	55	11,100	7,000
60	12,500	8,100	60	10,700	6,700
65	11,900	7,700	65	10,300	6,400
70	11,400	7,300	70	10,000	6,200
75	10,700	7,000	75	9,700	5,900
80	9,400	6,700	80	9,400	5,700
85	8,300	6,400	85	8,800	5,500
90	7,300	6,100	90	7,800	5,300
95	6,500	5,800	95	6,900	5,100
100	5,700	5,600	100	6,100	5,000
105	5,100	5,400	105	5,400	4,800
110	4,500	5,200	110	4,700	4,700
115	3,900	4,700	115	4,100	4,600
120	3,400	4,200	120	3,600	4,500
125	3,000	3,800	125	3,100	4,200
130		3,400	130		3,700
135		3,000	135		3,300
140		2,600	140		2,900
145		2,300	145		2,500
150		2,000	150		2,200
155		1,800	155		

This information is not for crane operation. Operator must refer to the in-cab information for crane operation. Rated lifting capacities shown on fully extended outriggers do not exceed 85% of the tipping loads and on tires do not exceed 75% of the tipping loads.

14,400 lb Counterweight – Fully Extended Outriggers – 360° Rotation (All Capacities Are Listed In Pounds)					
98.7 ft Main Boom Length 30° Fly Offset			98.7 ft Main Boom Length 45° Fly Offset		
Radius (ft)	Fly Length (ft)		Radius (ft)	Fly Length (ft)	
	38	64		38	64
45	10,100		45		
50	9,800		50		
55	9,500		55	8,600	
60	9,300		60	8,400	
65	9,000	5,400	65	8,300	
70	8,800	5,200	70	8,100	
75	8,600	5,100	75	8,000	
80	8,500	4,900	80	7,900	4,400
85	8,300	4,800	85	7,800	4,300
90	8,200	4,700	90	7,700	4,300
95	7,200	4,600	95	7,400	4,200
100	6,400	4,500	100	6,500	4,200
105	5,600	4,400	105	5,700	4,100
110	4,900	4,300	110		4,100
115	4,300	4,200	115		4,100
120		4,200	120		4,100
125		4,100	125		4,100
130		4,000	130		4,100
135		3,500	135		3,600
140		3,100	140		
145		2,600	145		

This information is not for crane operation. Operator must refer to the in-cab information for crane operation. Rated lifting capacities shown on fully extended outriggers do not exceed 85% of the tipping loads and on tires do not exceed 75% of the tipping loads.

14,400 lb Counterweight – Fully Extended Outriggers – 360° Rotation (All Capacities Are Listed In Pounds)									
127 ft Main Boom Length 2° Fly Offset					127 ft Main Boom Length 15° Fly Offset				
Radius (ft)	Fly Length (ft)				Radius (ft)	Fly Length (ft)			
	38	64	80	96		38	64	80	96
35	10,900				35				
40	10,900				40				
45	10,900	7,300			45	10,400			
50	10,900	7,300	5,800		50	10,300			
55	10,900	7,200	5,800	4,500	55	10,100			
60	10,900	7,100	5,800	4,500	60	9,900			
65	10,700	6,900	5,800	4,500	65	9,700	6,100	5,600	
70	10,500	6,800	5,800	4,500	70	9,500	6,000	5,300	4,200
75	10,200	6,600	5,800	4,500	75	9,300	5,800	5,000	3,900
80	9,600	6,500	5,500	4,100	80	9,000	5,600	4,700	3,700
85	8,500	6,300	5,200	3,900	85	8,500	5,500	4,400	3,400
90	7,600	6,100	4,900	3,600	90	8,000	5,300	4,200	3,200
95	6,700	5,900	4,600	3,400	95	7,100	5,200	4,000	3,000
100	5,900	5,700	4,400	3,200	100	6,300	5,100	3,800	2,800
105	5,300	5,400	4,200	3,000	105	5,600	4,900	3,600	2,600
110	4,700	5,100	4,000	2,800	110	5,000	4,700	3,500	2,500
115	4,100	4,700	3,800	2,600	115	4,400	4,500	3,300	2,300
120	3,600	4,200	3,600	2,500	120	3,900	4,300	3,200	2,200
125	3,200	3,800	3,400	2,300	125	3,400	4,100	3,000	2,100
130	2,800	3,300	3,200	2,200	130	3,000	3,800	2,900	1,900
135	2,400	2,900	2,800	2,100	135	2,600	3,300	2,800	1,800
140	2,100	2,600	2,400	2,000	140	2,200	3,000	2,700	1,700
145	1,800	2,300	2,100	1,800	145	1,900	2,600	2,400	1,600
150	1,500	2,000	1,800	1,700	150	1,600	2,300	2,100	1,500
155	1,200	1,700	1,500	1,500	155	1,300	2,000	1,800	1,500
160		1,400	1,300	1,200	160		1,700	1,500	1,400
165		1,200	1,000		165		1,400	1,200	1,200
170		1,000			170		1,100	1,000	1,000

This information is not for crane operation. Operator must refer to the in-cab information for crane operation. Rated lifting capacities shown on fully extended outriggers do not exceed 85% of the tipping loads and on tires do not exceed 75% of the tipping loads.

14,400 lb Counterweight – Fully Extended Outriggers – 360° Rotation (All Capacities Are Listed In Pounds)									
127 ft Main Boom Length 30° Fly Offset					127 ft Main Boom Length 45° Fly Offset				
Radius (ft)	Fly Length (ft)				Radius (ft)	Fly Length (ft)			
	38	64	80	96		38	64	80	96
55	9,100				55				
60	8,900				60				
65	8,700				65	8,100			
70	8,600				70	8,000			
75	8,500				75	7,900			
80	8,300	4,900	3,900		80	7,700			
85	8,000	4,800	3,700	3,000	85	7,700			
90	7,700	4,700	3,500	2,800	90	7,400	4,200	3,100	
95	7,400	4,600	3,400	2,600	95	7,200	4,200	2,900	2,300
100	6,700	4,500	3,200	2,400	100	6,900	4,100	2,800	2,200
105	6,000	4,400	3,100	2,300	105	6,200	4,100	2,700	2,100
110	5,300	4,300	2,900	2,200	110	5,500	4,100	2,600	1,900
115	4,700	4,200	2,800	2,000	115	4,900	4,000	2,500	1,800
120	4,100	4,000	2,700	1,900	120	4,300	3,900	2,500	1,700
125	3,600	3,900	2,600	1,800	125	3,700	3,800	2,400	1,600
130	3,200	3,700	2,500	1,700	130		3,600	2,300	1,500
135	2,700	3,600	2,500	1,600	135		3,500	2,300	1,500
140	2,300	3,300	2,400	1,500	140		3,400	2,200	1,400
145	1,900	2,900	2,300	1,400	145		3,100	2,200	1,300
150		2,500	2,300	1,300	150		2,700	2,100	1,200
155		2,200	2,100	1,300	155		2,300	2,100	1,200
160		1,900	1,800	1,200	160		1,900	1,900	1,100
165		1,500	1,500	1,200	165			1,600	1,100
170		1,200	1,200	1,100	170			1,300	1,100
175				1,000	175				1,000

This information is not for crane operation. Operator must refer to the in-cab information for crane operation. Rated lifting capacities shown on fully extended outriggers do not exceed 85% of the tipping loads and on tires do not exceed 75% of the tipping loads.

18,400 lb Counterweight – Fully Extended Outriggers – 360° Rotation (All Capacities Are Listed In Pounds)					
98.7 ft Main Boom Length 2° Fly Offset			98.7 ft Main Boom Length 15° Fly Offset		
Radius (ft)	Fly Length (ft)		Radius (ft)	Fly Length (ft)	
	38	64		38	64
30	16,200		30		
35	15,600	10,300	35		
40	14,900	9,900	40	12,500	
45	14,300	9,400	45	12,000	
50	13,600	9,000	50	11,500	7,400
55	13,000	8,500	55	11,100	7,000
60	12,500	8,100	60	10,700	6,700
65	11,900	7,700	65	10,300	6,400
70	11,400	7,300	70	10,000	6,200
75	11,000	7,000	75	9,700	5,900
80	10,500	6,700	80	9,400	5,700
85	9,400	6,400	85	9,100	5,500
90	8,400	6,100	90	8,800	5,300
95	7,500	5,800	95	7,800	5,100
100	6,700	5,600	100	7,000	5,000
105	5,900	5,400	105	6,200	4,800
110	5,300	5,200	110	5,500	4,700
115	4,700	5,000	115	4,900	4,600
120	4,200	4,900	120	4,400	4,500
125	3,700	4,500	125	3,800	4,400
130		4,100	130		4,300
135		3,700	135		3,900
140		3,300	140		3,500
145		2,900	145		3,100
150		2,600	150		2,800
155		2,300	155		

This information is not for crane operation. Operator must refer to the in-cab information for crane operation. Rated lifting capacities shown on fully extended outriggers do not exceed 85% of the tipping loads and on tires do not exceed 75% of the tipping loads.

18,400 lb Counterweight – Fully Extended Outriggers – 360° Rotation (All Capacities Are Listed In Pounds)					
98.7 ft Main Boom Length 30° Fly Offset			98.7 ft Main Boom Length 45° Fly Offset		
Radius (ft)	Fly Length (ft)		Radius (ft)	Fly Length (ft)	
	38	64		38	64
45	10,100		45		
50	9,800		50		
55	9,500		55	8,600	
60	9,300		60	8,400	
65	9,000	5,400	65	8,300	
70	8,800	5,200	70	8,100	
75	8,600	5,100	75	8,000	
80	8,500	4,900	80	7,900	4,400
85	8,300	4,800	85	7,800	4,300
90	8,200	4,700	90	7,700	4,300
95	8,000	4,600	95	7,600	4,200
100	7,300	4,500	100	7,500	4,200
105	6,500	4,400	105	6,600	4,100
110	5,700	4,300	110		4,100
115	5,100	4,200	115		4,100
120	4,400	4,200	120		4,100
125		4,100	125		4,100
130		4,100	130		4,100
135		4,100	135		4,100
140		3,700	140		
145		3,200	145		

This information is not for crane operation. Operator must refer to the in-cab information for crane operation. Rated lifting capacities shown on fully extended outriggers do not exceed 85% of the tipping loads and on tires do not exceed 75% of the tipping loads.

18,400 lb Counterweight – Fully Extended Outriggers – 360° Rotation (All Capacities Are Listed In Pounds)									
127 ft Main Boom Length 2° Fly Offset					127 ft Main Boom Length 15° Fly Offset				
Radius (ft)	Fly Length (ft)				Radius (ft)	Fly Length (ft)			
	38	64	80	96		38	64	80	96
35	10,900				35				
40	10,900				40				
45	10,900	7,300			45	10,400			
50	10,900	7,300	5,800		50	10,300			
55	10,900	7,200	5,800	4,500	55	10,100			
60	10,900	7,100	5,800	4,500	60	9,900			
65	10,700	6,900	5,800	4,500	65	9,700	6,100	5,600	
70	10,500	6,800	5,800	4,500	70	9,500	6,000	5,300	4,200
75	10,200	6,600	5,800	4,500	75	9,300	5,800	5,000	3,900
80	9,600	6,500	5,500	4,100	80	9,000	5,600	4,700	3,700
85	9,100	6,300	5,200	3,900	85	8,500	5,500	4,400	3,400
90	8,600	6,100	4,900	3,600	90	8,100	5,300	4,200	3,200
95	7,700	5,900	4,600	3,400	95	7,800	5,200	4,000	3,000
100	6,900	5,700	4,400	3,200	100	7,300	5,100	3,800	2,800
105	6,200	5,400	4,200	3,000	105	6,500	4,900	3,600	2,600
110	5,500	5,100	4,000	2,800	110	5,800	4,700	3,500	2,500
115	4,900	4,900	3,800	2,600	115	5,200	4,500	3,300	2,300
120	4,400	4,700	3,600	2,500	120	4,700	4,300	3,200	2,200
125	3,900	4,500	3,400	2,300	125	4,200	4,100	3,000	2,100
130	3,500	4,000	3,300	2,200	130	3,700	4,000	2,900	1,900
135	3,100	3,600	3,200	2,100	135	3,300	3,800	2,800	1,800
140	2,700	3,200	3,000	2,000	140	2,900	3,600	2,700	1,700
145	2,400	2,900	2,700	1,800	145	2,500	3,200	2,600	1,600
150	2,100	2,600	2,400	1,700	150	2,200	2,900	2,500	1,500
155	1,800	2,300	2,100	1,700	155	1,800	2,500	2,400	1,500
160		2,000	1,800	1,600	160		2,200	2,100	1,400
165		1,700	1,500	1,500	165		1,900	1,800	1,300
170		1,500	1,300	1,200	170		1,700	1,500	1,300
175		1,300	1,100	1,000	175		1,400	1,300	1,200
180		1,100			180		1,100	1,000	1,000

This information is not for crane operation. Operator must refer to the in-cab information for crane operation. Rated lifting capacities shown on fully extended outriggers do not exceed 85% of the tipping loads and on tires do not exceed 75% of the tipping loads.

18,400 lb Counterweight – Fully Extended Outriggers – 360° Rotation (All Capacities Are Listed In Pounds)									
127 ft Main Boom Length 30° Fly Offset					127 ft Main Boom Length 45° Fly Offset				
Radius (ft)	Fly Length (ft)				Radius (ft)	Fly Length (ft)			
	38	64	80	96		38	64	80	96
55	9,100				55				
60	8,900				60				
65	8,700				65	8,100			
70	8,600				70	8,000			
75	8,500				75	7,900			
80	8,300	4,900	3,900		80	7,700			
85	8,000	4,800	3,700	3,000	85	7,700			
90	7,700	4,700	3,500	2,800	90	7,400	4,200	3,100	
95	7,400	4,600	3,400	2,600	95	7,200	4,200	2,900	2,300
100	7,100	4,500	3,200	2,400	100	6,900	4,100	2,800	2,200
105	6,800	4,400	3,100	2,300	105	6,700	4,100	2,700	2,100
110	6,100	4,300	2,900	2,200	110	6,300	4,100	2,600	1,900
115	5,500	4,200	2,800	2,000	115	5,600	4,000	2,500	1,800
120	4,900	4,000	2,700	1,900	120	5,000	3,900	2,500	1,700
125	4,400	3,900	2,600	1,800	125	4,400	3,800	2,400	1,600
130	3,900	3,700	2,500	1,700	130	3,900	3,600	2,300	1,500
135	3,400	3,600	2,500	1,600	135		3,500	2,300	1,500
140	3,000	3,500	2,400	1,500	140		3,400	2,200	1,400
145	2,600	3,400	2,300	1,400	145		3,400	2,200	1,300
150		3,100	2,300	1,300	150		3,300	2,100	1,200
155		2,800	2,200	1,300	155		2,800	2,100	1,200
160		2,400	2,200	1,200	160		2,400	2,100	1,100
165		2,100	2,000	1,200	165			2,100	1,100
170		1,700	1,700	1,100	170			1,800	1,100
175		1,400	1,400	1,100	175				1,000
180			1,200	1,100	180				1,000
185					185				1,000

This information is not for crane operation. Operator must refer to the in-cab information for crane operation. Rated lifting capacities shown on fully extended outriggers do not exceed 85% of the tipping loads and on tires do not exceed 75% of the tipping loads.



## Main Boom Lift Capacity Charts – Optional (Metric)

0t Counterweight – Fully Extended Outriggers – 360° Rotation (All Capacities Are Listed In Kilograms)											
Radius (m)	Boom Length (m)										Radius (m)
	12.5	15.2	18.3	21.3	24.4	27.4	30.5	33.5	36.6	38.71	
3	57 600	50 450	48 450	33 750							3
3.5	48 800	48 250	48 450	36 700	28 500						3.5
4	42 150	42 750	43 250	35 000	28 500						4
4.5	36 900	37 550	38 100	35 000	28 500	27 850					4.5
5	32 750	33 600	33 900	33 800	28 500	27 850					5
6	26 400	27 300	27 650	27 850	27 900	26 150	21 750	14 850			6
7	21 850	22 750	23 250	23 450	23 350	23 250	20 200	14 850	11 550	10 250	7
8	16 650	17 750	18 300	18 550	18 400	18 300	18 200	14 700	11 550	10 250	8
9	13 100	14 200	14 900	15 000	15 150	15 150	15 000	13 200	11 550	10 250	9
10	10 450	11 600	12 300	12 400	12 850	12 950	12 400	12 550	11 550	10 250	10
12		7 850	8 600	9 050	9 150	9 250	9 250	9 150	9 000	8 950	12
14			6 250	6 700	6 800	6 900	6 900	6 750	6 650	6 600	14
16			4 600	5 100	5 250	5 300	5 350	5 200	5 100	5 050	16
18				3 900	4 050	4 150	4 200	4 050	3 950	3 900	18
20					3 150	3 300	3 300	3 200	3 100	3 050	20
22					2 450	2 600	2 600	2 500	2 400	2 350	22
24						2 000	2 050	1 950	1 850	1 800	24
26							1 600	1 500	1 400	1 350	26
28							1 200	1 100	1 050	1 000	28
30								800	700	650	30
32									450	400	32

This information is not for crane operation. Operator must refer to the in-cab information for crane operation. Rated lifting capacities shown meet ISO 4305 standards.

<b>0t Counterweight – On Tires – Stationary – Boom Centered Over Rear</b> (All Capacities Are Listed In Kilograms)							
Radius (m)	Boom Length (m)						Radius (m)
	12.5	15.2	18.3	21.3	24.4	27.4	
3	15 300						3
3.5	14 200	14 250					3.5
4	12 850	13 550	12 000				4
4.5	10 550	11 500	12 000	9 200			4.5
5	8 800	9 650	10 300	9 200			5
6	6 200	7 050	7 700	8 100	7 500		6
7	4 500	5 300	5 900	6 300	6 400		7
8	3 200	4 050	4 600	5 000	5 150	5 250	8
9	2 250	3 050	3 650	4 000	4 150	4 250	9
10	1 500	2 300	2 850	3 250	3 400	3 500	10
12		1 150	1 700	2 100	2 250	2 350	12
14			900	1 300	1 400	1 500	14
16				700	850	900	16
18						450	18

<b>0t Counterweight – On Tires – Pick &amp; Carry (1 km/h) – Boom Centered Over Rear</b> (All Capacities Are Listed In Kilograms)							
Radius (m)	Boom Length (m)						Radius (m)
	12.5	15.2	18.3	21.3	24.4	27.4	
3	10 800						3
3.5	9 950	10 050					3.5
4	9 100	9 550	9 850				4
4.5	8 350	8 800	9 100	9 200			4.5
5	7 650	8 100	8 450	8 650			5
6	5 550	6 300	6 850	7 200	7 300		6
7	4 000	4 750	5 300	5 650	5 750		7
8	2 850	3 600	4 150	4 500	4 600	4 700	8
9	2 000	2 750	3 250	3 600	3 700	3 800	9
10	1 300	2 050	2 550	2 900	3 000	3 100	10
12		1 050	1 550	1 850	2 000	2 050	12
14			800	1 150	1 250	1 350	14
16				600	750	800	16
18						400	18

This information is not for crane operation. Operator must refer to the in-cab information for crane operation. Rated lifting capacities shown meet ISO 4305 standards.

**4.8t Counterweight – Fully Extended Outriggers – 360° Rotation**  
 (All Capacities Are Listed In Kilograms)

Radius (m)	Boom Length (m)										Radius (m)
	12.5	15.2	18.3	21.3	24.4	27.4	30.5	33.5	36.6	38.71	
3	63 150	50 450	48 450	33 750							3
3.5	53 800	48 250	48 450	36 700	28 500						3.5
4	46 550	46 300	47 550	35 000	28 500						4
4.5	40 850	41 450	41 950	35 000	28 500	27 850					4.5
5	36 250	36 900	37 400	35 000	28 500	27 850					5
6	29 350	30 250	30 550	30 450	28 500	26 150	21 750	14 850			6
7	24 400	25 300	25 600	25 950	25 900	23 900	20 200	14 850	11 550	10 250	7
8	20 650	21 550	22 050	22 300	22 200	21 900	18 750	14 700	11 550	10 250	8
9	17 350	18 450	19 000	19 250	19 100	19 000	17 450	13 800	11 550	10 250	9
10	14 150	15 250	15 850	16 050	15 950	15 850	15 750	12 550	11 550	10 250	10
12		10 950	11 700	11 800	11 950	11 900	11 800	11 200	11 450	10 250	12
14			8 900	9 350	9 500	9 600	9 550	9 450	9 350	9 300	14
16			6 950	7 400	7 550	7 650	7 650	7 500	7 400	7 350	16
18				5 900	6 050	6 150	6 150	6 050	5 950	5 850	18
20					4 950	5 050	5 100	4 950	4 850	4 800	20
22					4 050	4 150	4 200	4 100	4 000	3 950	22
24						3 450	3 500	3 400	3 300	3 250	24
26							2 900	2 800	2 700	2 650	26
28							2 400	2 300	2 250	2 200	28
30								1 900	1 800	1 800	30
32									1 450	1 400	32

This information is not for crane operation. Operator must refer to the in-cab information for crane operation. Rated lifting capacities shown meet ISO 4305 standards.

<b>4.8t Counterweight – On Tires – Stationary – Boom Centered Over Rear</b> (All Capacities Are Listed In Kilograms)							
Radius (m)	Boom Length (m)						Radius (m)
	12.5	15.2	18.3	21.3	24.4	27.4	
3	15 200						3
3.5	14 200	14 200					3.5
4	13 100	13 550	13 800				4
4.5	12 150	12 600	12 900	10 700			4.5
5	11 300	11 700	12 050	10 700			5
6	9 300	10 150	10 600	10 700	8 150		6
7	7 100	7 900	8 500	8 900	8 150		7
8	5 450	6 250	6 850	7 250	7 350	6 300	8
9	4 250	5 050	5 600	5 950	6 100	6 200	9
10	3 250	4 050	4 650	5 000	5 150	5 250	10
12		2 600	3 150	3 550	3 700	3 800	12
14			2 150	2 500	2 650	2 750	14
16			1 400	1 750	1 900	2 000	16
18				1 200	1 300	1 400	18
20					850	950	20
22					500	600	22

<b>4.8t Counterweight – On Tires – Pick &amp; Carry (1 km/h) – Boom Centered Over Rear</b> (All Capacities Are Listed In Kilograms)							
Radius (m)	Boom Length (m)						Radius (m)
	12.5	15.2	18.3	21.3	24.4	27.4	
3	10 750						3
3.5	9 950	10 050					3.5
4	9 100	9 500	9 800				4
4.5	8 300	8 750	9 050	9 150			4.5
5	7 650	8 100	8 450	8 650			5
6	6 450	6 950	7 300	7 500	7 450		6
7	5 450	5 950	6 350	6 600	6 650		7
8	4 600	5 150	5 550	5 800	5 850	5 950	8
9	3 800	4 450	4 850	5 150	5 250	5 300	9
10	2 900	3 600	4 150	4 450	4 600	4 700	10
12		2 350	2 850	3 150	3 300	3 350	12
14			1 900	2 250	2 350	2 450	14
16			1 250	1 600	1 700	1 800	16
18				1 050	1 150	1 250	18
20					750	850	20
22					450	500	22

This information is not for crane operation. Operator must refer to the in-cab information for crane operation. Rated lifting capacities shown meet ISO 4305 standards.

<b>6.4t Counterweight – Fully Extended Outriggers – 360° Rotation</b> (All Capacities Are Listed In Kilograms)												
Radius (m)	Boom Length (m)										Radius (m)	
	12.5	15.2	18.3	21.3	24.4	27.4	30.5	33.5	36.6	38.71		
2.5	70 000											3
3	64 250	50 450	48 450	33 750								3
3.5	55 500	48 250	48 450	36 700	28 500							3.5
4	48 000	46 300	48 450	35 000	28 500							4
4.5	42 150	42 750	43 250	35 000	28 500	27 850						4.5
5	37 450	38 050	38 600	35 000	28 500	27 850						5
6	30 350	31 200	31 550	31 450	28 500	26 150	21 750	14 850				6
7	25 250	26 150	26 450	26 400	26 750	23 900	20 200	14 850	11 550	10 250		7
8	21 400	22 300	22 700	23 050	22 950	21 900	18 750	14 700	11 550	10 250		8
9	18 400	19 300	19 800	20 050	19 950	19 900	17 450	13 800	11 550	10 250		9
10	15 400	16 500	17 050	17 300	17 150	17 050	16 300	12 550	11 550	10 250		10
12		11 900	12 650	12 750	12 900	12 850	12 750	11 200	11 450	10 250		12
14			9 700	9 850	10 300	10 300	9 900	10 050	10 150	10 100		14
16			7 650	8 050	8 250	8 300	8 350	8 200	8 100	8 050		16
18				6 550	6 700	6 800	6 850	6 700	6 600	6 550		18
20					5 550	5 650	5 700	5 550	5 450	5 400		20
22					4 600	4 700	4 750	4 600	4 550	4 450		22
24						3 900	3 950	3 850	3 800	3 700		24
26							3 350	3 250	3 150	3 100		26
28							2 800	2 700	2 650	2 600		28
30								2 250	2 200	2 150		30
32									1 800	1 750		32

This information is not for crane operation. Operator must refer to the in-cab information for crane operation. Rated lifting capacities shown meet ISO 4305 standards.

<b>6.4t Counterweight – On Tires – Stationary – Boom Centered Over Rear</b> (All Capacities Are Listed In Kilograms)							
Radius (m)	Boom Length (m)						Radius (m)
	12.5	15.2	18.3	21.3	24.4	27.4	
3	15 250						3
3.5	14 200	14 200					3.5
4	13 100	13 500	13 800				4
4.5	12 150	12 550	12 850	10 700			4.5
5	11 300	11 700	12 050	10 700			5
6	9 750	10 250	10 600	10 700	8 950		6
7	7 950	8 800	9 400	9 600	8 950		7
8	6 200	7 000	7 600	8 000	8 100	6 900	8
9	4 900	5 700	6 250	6 650	6 750	6 850	9
10	3 850	4 650	5 200	5 600	5 750	5 800	10
12		3 100	3 650	4 050	4 150	4 250	12
14			2 550	2 950	3 050	3 150	14
16			1 750	2 150	2 250	2 350	16
18				1 500	1 650	1 750	18
20					1 150	1 250	20
22					750	850	22
24						500	24

<b>6.4t Counterweight – On Tires – Pick &amp; Carry (1 km/h) – Boom Centered Over Rear</b> (All Capacities Are Listed In Kilograms)							
Radius (m)	Boom Length (m)						Radius (m)
	12.5	15.2	18.3	21.3	24.4	27.4	
3	10 650						3
3.5	9 900	9 950					3.5
4	9 050	9 450	9 700				4
4.5	8 300	8 750	9 050	9 100			4.5
5	7 650	8 100	8 400	8 600			5
6	6 450	6 950	7 300	7 500	7 450		6
7	5 450	5 950	6 350	6 600	6 650		7
8	4 600	5 150	5 550	5 800	5 850	5 950	8
9	3 850	4 450	4 850	5 150	5 250	5 300	9
10	3 200	3 800	4 250	4 550	4 650	4 700	10
12		2 750	3 250	3 550	3 650	3 750	12
14			2 300	2 600	2 750	2 800	14
16			1 550	1 900	2 000	2 100	16
18				1 350	1 450	1 550	18
20					1 000	1 100	20
22					650	750	22
24						450	24

This information is not for crane operation. Operator must refer to the in-cab information for crane operation. Rated lifting capacities shown meet ISO 4305 standards.

<b>8.2t Counterweight — Fully Extended Outriggers — 360° Rotation</b> (All Capacities Are Listed In Kilograms)												
Radius (m)	Boom Length (m)										Radius (m)	
	12.5	15.2	18.3	21.3	24.4	27.4	30.5	33.5	36.6	38.71		
2.5	70 000											3
3	64,250	50,450	48,450	33,750								3
3.5	57,250	48,250	48,450	36,700	28,500							3.5
4	49,600	46,300	48,450	35,000	28,500							4
4.5	43,600	44,200	44,650	35,000	28,500	27,850						4.5
5	38,750	39,350	39,900	35,000	28,500	27,850						5
6	31,400	32,200	32,600	32,500	28,500	26,150	21,750	14,850				6
7	26,200	27,050	27,400	27,350	27,000	23,900	20,200	14,850	11,550	10,250		7
8	22,250	23,100	23,450	23,800	23,700	21,900	18,750	14,700	11,550	10,250		8
9	19,150	20,000	20,500	20,750	20,650	20,250	17,450	13,800	11,550	10,250		9
10	16,650	17,550	18,050	18,300	18,200	18,150	16,300	12,550	11,550	10,250		10
12		12,950	13,550	13,800	13,650	13,550	13,500	11,200	11,450	10,250		12
14			10,550	10,700	10,850	10,850	10,750	10,050	10,400	10,150		14
16			8,350	8,550	8,950	9,050	8,600	8,950	8,850	8,750		16
18				7,200	7,350	7,450	7,450	7,350	7,250	7,200		18
20					6,100	6,200	6,250	6,100	6,000	5,950		20
22					5,100	5,250	5,300	5,200	5,100	5,050		22
24						4,450	4,500	4,400	4,300	4,250		24
26							3,800	3,700	3,650	3,600		26
28							3,250	3,150	3,050	3,000		28
30								2,650	2,600	2,550		30
32									2,200	2,150		32

This information is not for crane operation. Operator must refer to the in-cab information for crane operation. Rated lifting capacities shown meet ISO 4305 standards.

<b>8.2t Counterweight – On Tires – Stationary – Boom Centered Over Rear</b> (All Capacities Are Listed In Kilograms)							
Radius (m)	Boom Length (m)						Radius (m)
	12.5	15.2	18.3	21.3	24.4	27.4	
3	14 850						3
3.5	13 850	13 850					3.5
4	12 800	13 200	13 450				4
4.5	11 850	12 300	12 600	12 650			4.5
5	11 050	11 500	11 750	11 950			5
6	9 500	10 000	10 350	10 600	8 550		6
7	8 250	8 800	9 150	9 400	8 550		7
8	7 050	7 750	8 150	8 400	8 500	7 250	8
9	5 600	6 400	6 950	7 350	7 500	7 250	9
10	4 500	5 300	5 850	6 200	6 350	6 450	10
12		3 600	4 200	4 550	4 700	4 800	12
14			3 000	3 400	3 500	3 600	14
16			2 150	2 500	2 650	2 750	16
18				1 850	2 000	2 100	18
20					1 450	1 550	20
22					1 050	1 100	22
24						750	24

<b>8.2t Counterweight – On Tires – Pick &amp; Carry (1 km/h) – Boom Centered Over Rear</b> (All Capacities Are Listed In Kilograms)							
Radius (m)	Boom Length (m)						Radius (m)
	12.5	15.2	18.3	21.3	24.4	27.4	
3	10 750						3
3.5	9 500	9 850					3.5
4	8 750	9 000	9 350				4
4.5	8 050	8 450	8 650	8 650			4.5
5	7 350	7 800	8 100	8 250			5
6	6 200	6 700	7 050	7 250	7 200		6
7	5 250	5 750	6 100	6 350	6 450		7
8	4 400	4 950	5 350	5 600	5 700	5 750	8
9	3 650	4 250	4 650	4 950	5 050	5 100	9
10	3 00	3 650	4 100	4 350	4 450	4 550	10
12		2 650	3 100	3 400	3 500	3 600	12
14			2 300	2 650	2 750	2 800	14
16			1 700	2 000	2 150	2 200	16
18				1 500	1 600	1 700	18
20					1 200	1 300	20
22					800	900	22
24						600	24

This information is not for crane operation. Operator must refer to the in-cab information for crane operation. Rated lifting capacities shown meet ISO 4305 standards.



## Fly Attachment Lift Capacity Charts – Optional (Metric)

0t Counterweight – Fully Extended Outriggers – 360° Rotation (All Capacities Are Listed In Kilograms)					
30.1m Main Boom Length – 11.58m Offset Fly Length					
Radius (m)	2° Fly Offset	15° Fly Offset	30° Fly Offset	45° Fly Offset	Radius (m)
9	7 350				9
10	7 200				10
12	6 800	5 700			12
14	6 400	5 400	4 550		14
16	5 250	5 150	4 400	3 900	16
18	4 100	4 500	4 250	3 800	18
20	3 200	3 550	3 900	3 750	20
22	2 500	2 800	3 100	3 350	22
24	1 950	2 200	2 450	2 650	24
26	1 500	1 700	1 950	2 100	26
28	1 100	1 300	1 500	1 600	28
30	800	950	1 100	1 200	30
32	500	650	750		32
34		400	450		34

0t Counterweight – Fully Extended Outriggers – 360° Rotation (All Capacities Are Listed In Kilograms)					
38.71m Main Boom Length – 11.58m Offset Fly Length					
Radius (m)	2° Fly Offset	15° Fly Offset	30° Fly Offset	45° Fly Offset	Radius (m)
10	4 950				10
12	4 950				12
14	4 950	4 700			14
16	4 950	4 600			16
18	4 200	4 500	4 050		18
20	3 300	3 650	3 950	3 650	20
22	2 600	2 950	3 250	3 500	22
24	2 050	2 350	2 600	2 800	24
26	1 600	1 850	2 100	2 250	26
28	1 200	1 400	1 650	1 800	28
30	900	1 050	1 250	1 400	30
32	600	750	950	1 050	32
34		500	650	750	34
36			400	450	36

This information is not for crane operation. Operator must refer to the in-cab information for crane operation. Rated lifting capacities shown meet ISO 4305 standards.

4.8t Counterweight – Fully Extended Outriggers – 360° Rotation (All Capacities Are Listed In Kilograms)					
30.1m Main Boom Length 2° Fly Offset			30.1m Main Boom Length 15° Fly Offset		
Radius (m)	Fly Length (m)		Radius (m)	Fly Length (m)	
	11.58	19.51		11.58	19.51
9	7 350		9		
10	7 200	4 750	10		
12	6 800	4 500	12	5 700	
14	6 400	4 250	14	5 400	
16	6 050	3 950	16	5 150	3 250
18	5 700	3 700	18	4 900	3 050
20	5 000	3 450	20	4 650	2 900
22	4 100	3 250	22	4 400	2 750
24	3 400	3 050	24	3 650	2 600
26	2 800	2 900	26	3 000	2 500
28	2 300	2 700	28	2 500	2 400
30	1 900	2 300	30	2 050	2 300
32	1 550	1 950	32	1 650	2 200
34	1 250	1 600	34	1 350	1 850
36	950	1 350	36	1 050	1 550
38	750	1 100	38	800	1 250
40		850	40		1 050
42		700	42		800
44		500	44		600
46		350	46		400

4.8t Counterweight – Fully Extended Outriggers – 360° Rotation (All Capacities Are Listed In Kilograms)					
30.1m Main Boom Length 30° Fly Offset			30.1m Main Boom Length 45° Fly Offset		
Radius (m)	Fly Length (m)		Radius (m)	Fly Length (m)	
	11.58	19.51		11.58	19.51
14	4 550		14		
16	4 400		16	3 900	
18	4 250		18	3 800	
20	4 100	2 450	20	3 750	
22	3 950	2 350	22	3 650	
24	3 850	2 250	24	3 600	2 000
26	3 250	2 150	26	3 400	1 950
28	2 700	2 100	28	2 800	1 900
30	2 200	2 050	30	2 300	1 900
32	1 800	2 000	32	1 850	1 850
34	1 400	1 950	34		1 850
36	1 100	1 750	36		1 850
38		1 450	38		1 550
40		1 150	40		1 200
42		900	42		
44		650	44		

This information is not for crane operation. Operator must refer to the in-cab information for crane operation. Rated lifting capacities shown meet ISO 4305 standards.

4.8t Counterweight – Fully Extended Outriggers – 360° Rotation (All Capacities Are Listed In Kilograms)							
38.71m Main Boom Length 2° Fly Offset				38.71m Main Boom Length 15° Fly Offset			
Radius (m)	Fly Length (m)			Radius (m)	Fly Length (m)		
	11.58	19.51	24.38		11.58	19.51	24.38
10	4 950			10			
12	4 950			12			
14	4 950	3 350	2 600	14	4 700		
16	4 950	3 300	2 600	16	4 600		
18	4 950	3 200	2 600	18	4 500		
20	4 850	3 150	2 600	20	4 400	2 750	2 500
22	4 200	3 050	2 600	22	4 300	2 650	2 300
24	3 500	2 950	2 550	24	3 750	2 550	2 150
26	2 900	2 850	2 350	26	3 150	2 500	2 000
28	2 400	2 700	2 200	28	2 600	2 400	1 850
30	2 000	2 300	2 050	30	2 200	2 300	1 750
32	1 650	1 900	1 850	32	1 800	2 200	1 650
34	1 350	1 600	1 550	34	1 450	1 850	1 550
36	1 050	1 300	1 250	36	1 200	1 550	1 450
38	800	1 050	1 000	38	950	1 300	1 200
40	600	850	800	40	700	1 050	950
42	400	650	600	42	500	850	750
44		500	400	44		650	550
46				46		450	400

4.8t Counterweight – Fully Extended Outriggers – 360° Rotation (All Capacities Are Listed In Kilograms)							
38.71m Main Boom Length 30° Fly Offset				38.71m Main Boom Length 45° Fly Offset			
Radius (m)	Fly Length (m)			Radius (m)	Fly Length (m)		
	11.58	19.51	24.38		11.58	19.51	24.38
18	4 050			18			
20	3 950			20	3 650		
22	3 850			22	3 600		
24	3 800	2 200		24	3 500		
26	3 400	2 150	1 650	26	3 450		
28	2 850	2 100	1 550	28	3 000	1 900	1 350
30	2 350	2 050	1 500	30	2 500	1 850	1 300
32	1 950	2 000	1 400	32	2 050	1 850	1 250
34	1 600	1 950	1 300	34	1 700	1 850	1 200
36	1 300	1 800	1 250	36	1 350	1 800	1 100
38	1 000	1 500	1 200	38	1 050	1 700	1 100
40	800	1 250	1 150	40		1 400	1 050
42	550	1 000	950	42		1 100	1 000
44		800	750	44		850	850
46		600	550	46		650	650
48		400		48		400	450

This information is not for crane operation. Operator must refer to the in-cab information for crane operation. Rated lifting capacities shown meet ISO 4305 standards.

6.4t Counterweight – Fully Extended Outriggers – 360° Rotation (All Capacities Are Listed In Kilograms)					
30.1m Main Boom Length 2° Fly Offset			30.1m ft Main Boom Length 15° Fly Offset		
Radius (m)	Fly Length (m)		Radius (m)	Fly Length (m)	
	11.58	19.51		11.58	19.51
9	7 350		9		
10	7 200	4 750	10		
12	6 800	4 500	12	5 700	
14	6 400	4 250	14	5 400	
16	6 050	3 950	16	5 150	3 250
18	5 700	3 700	18	4 900	3 050
20	5 400	3 450	20	4 650	2 900
22	4 600	3 250	22	4 450	2 750
24	3 850	3 050	24	4 100	2 600
26	3 250	2 900	26	3 450	2 500
28	2 700	2 700	28	2 900	2 400
30	2 250	2 600	30	2 400	2 300
32	1 900	2 250	32	2 000	2 200
34	1 550	1 950	34	1 650	2 100
36	1 250	1 650	36	1 350	1 850
38	1 000	1 350	38	1 050	1 550
40		1 150	40		1 300
42		950	42		1 050
44		750	44		850
46		600	46		650

6.4t Counterweight – Fully Extended Outriggers – 360° Rotation (All Capacities Are Listed In Kilograms)					
30.1m Main Boom Length 30° Fly Offset			30.1m Main Boom Length 45° Fly Offset		
Radius (m)	Fly Length (m)		Radius (m)	Fly Length (m)	
	11.58	19.51		11.58	19.51
14	4 550		14		
16	4 400		16	3 900	
18	4 250		18	3 800	
20	4 100	2 450	20	3 750	
22	3 950	2 350	22	3 650	
24	3 850	2 250	24	3 600	2 000
26	3 650	2 150	26	3 500	1 950
28	3 100	2 100	28	3 200	1 900
30	2 550	2 050	30	2 650	1 900
32	2 150	2 000	32	2 200	1 850
34	1 750	1 950	34		1 850
36	1 400	1 900	36		1 850
38		1 750	38		1 850
40		1 450	40		1 500
42		1 150	42		
44		900	44		

This information is not for crane operation. Operator must refer to the in-cab information for crane operation. Rated lifting capacities shown meet ISO 4305 standards.

<b>6.4t Counterweight – Fully Extended Outriggers – 360° Rotation (All Capacities Are Listed In Kilograms)</b>									
<b>38.71m Main Boom Length 2° Fly Offset</b>					<b>38.71m Main Boom Length 15° Fly Offset</b>				
Radius (m)	Fly Length (m)				Radius (m)	Fly Length (m)			
	11.58	19.51	24.38	29.26		11.58	19.51	24.38	29.26
10	4 950				10				
12	4 950				12				
14	4 950	3 350	2 600		14	4 700			
16	4 950	3 300	2 600	2 050	16	4 600			
18	4 950	3 200	2 600	2 050	18	4 500			
20	4 850	3 150	2 600	2 050	20	4 400	2 750	2 500	
22	4 750	3 050	2 600	2 050	22	4 300	2 650	2 300	1 850
24	3 950	2 950	2 550	1 900	24	4 100	2 550	2 150	1 700
26	3 350	2 850	2 350	1 750	26	3 600	2 500	2 000	1 550
28	2 800	2 750	2 200	1 600	28	3 000	2 400	1 850	1 400
30	2 350	2 650	2 050	1 450	30	2 550	2 300	1 750	1 300
32	2 000	2 250	1 900	1 350	32	2 150	2 250	1 650	1 200
34	1 650	1 900	1 750	1 250	34	1 800	2 100	1 550	1 100
36	1 350	1 600	1 550	1 150	36	1 500	1 850	1 450	1 000
38	1 100	1 350	1 300	1 050	38	1 200	1 600	1 400	950
40	900	1 100	1 050	1 000	40	950	1 300	1 250	850
42	650	900	850	800	42	750	1 100	1 000	800
44	500	750	650	600	44	550	900	800	750
46		550	500	450	46		700	600	600
48		400			48		500	450	450

<b>6.4t Counterweight – Fully Extended Outriggers – 360° Rotation (All Capacities Are Listed In Kilograms)</b>									
<b>38.71m Main Boom Length 30° Fly Offset</b>					<b>38.71m Main Boom Length 45° Fly Offset</b>				
Radius (m)	Fly Length (m)				Radius (m)	Fly Length (m)			
	11.58	19.51	24.38	29.26		11.58	19.51	24.38	29.26
18	4 050				18				
20	3 950				20	3 650			
22	3 850				22	3 600			
24	3 800	2 200			24	3 500			
26	3 650	2 150	1 650	1 350	26	3 450			
28	3 250	2 100	1 550	1 250	28	3 300	1 900	1 350	
30	2 750	2 050	1 500	1 150	30	2 850	1 850	1 300	1 000
32	2 300	2 000	1 400	1 050	32	2 400	1 850	1 250	950
34	1 950	1 950	1 300	950	34	2 000	1 850	1 200	850
36	1 600	1 850	1 250	900	36	1 650	1 800	1 100	800
38	1 300	1 750	1 200	800	38	1 350	1 700	1 100	750
40	1 050	1 500	1 150	750	40		1 650	1 050	700
42	800	1 250	1 100	700	42		1 350	1 000	650
44	600	1 050	1 000	650	44		1 100	1 000	600
46		800	800	600	46		850	900	550
48		600	600	550	48		650	650	500
50		450	400	400	50			450	500

This information is not for crane operation. Operator must refer to the in-cab information for crane operation. Rated lifting capacities shown meet ISO 4305 standards.

8.2t Counterweight – Fully Extended Outriggers – 360° Rotation (All Capacities Are Listed In Kilograms)					
30.1m Main Boom Length 2° Fly Offset			30.1m Main Boom Length 15° Fly Offset		
Radius (m)	Fly Length (m)		Radius (m)	Fly Length (m)	
	11.58	19.51		11.58	19.51
9	7 350		9		
10	7 200	4 750	10		
12	6 800	4 500	12	5 700	
14	6 400	4 250	14	5 400	
16	6 050	3 950	16	5 150	3 250
18	5 700	3 700	18	4 900	3 050
20	5 400	3 450	20	4 650	2 900
22	5 100	3 250	22	4 450	2 750
24	4 400	3 050	24	4 300	2 600
26	3 700	2 900	26	3 950	2 500
28	3 150	2 700	28	3 350	2 400
30	2 650	2 600	30	2 800	2 300
32	2 250	2 450	32	2 400	2 200
34	1 900	2 300	34	2 000	2 100
36	1 600	1 950	36	1 700	2 050
38	1 350	1 700	38	1 350	1 850
40		1 450	40		1 600
42		1 200	42		1 350
44		1 000	44		1 100
46		850	46		900

8.2t Counterweight – Fully Extended Outriggers – 360° Rotation (All Capacities Are Listed In Kilograms)					
30.1m Main Boom Length 30° Fly Offset			30.1m Main Boom Length 45° Fly Offset		
Radius (m)	Fly Length (m)		Radius (m)	Fly Length (m)	
	11.58	19.51		11.58	19.51
14	4 550		14		
16	4 400		16	3 900	
18	4 250		18	3 800	
20	4 100	2 450	20	3 750	
22	3 950	2 350	22	3 650	
24	3 850	2 250	24	3 600	2 000
26	3 750	2 150	26	3 500	1 950
28	3 500	2 100	28	3 450	1 900
30	2 950	2 050	30	3 050	1 900
32	2 500	2 000	32	2 550	1 850
34	2 100	1 950	34		1 850
36	1 750	1 900	36		1 850
38		1 850	38		1 850
40		1 700	40		1 800
42		1 450	42		
44		1 150	44		

This information is not for crane operation. Operator must refer to the in-cab information for crane operation. Rated lifting capacities shown meet ISO 4305 standards.

8.2t Counterweight – Fully Extended Outriggers – 360° Rotation (All Capacities Are Listed In Kilograms)									
38.71m Main Boom Length 2° Fly Offset					38.71m Main Boom Length 15° Fly Offset				
Radius (m)	Fly Length (m)				Radius (m)	Fly Length (m)			
	11.58	19.51	24.38	29.26		11.58	19.51	24.38	29.26
10	4 950				10				
12	4 950				12				
14	4 950	3 350	2 600		14	4 700			
16	4 950	3 300	2 600	2 050	16	4 600			
18	4 950	3 200	2 600	2 050	18	4 500			
20	4 850	3 150	2 600	2 050	20	4 400	2 750	2 500	
22	4 750	3 050	2 600	2 050	22	4 300	2 650	2 300	1 850
24	4 450	2 950	2 550	1 900	24	4 100	2 550	2 150	1 700
26	3 800	2 850	2 350	1 750	26	3 850	2 500	2 000	1 550
28	3 250	2 750	2 200	1 600	28	3 450	2 400	1 850	1 400
30	2 750	2 650	2 050	1 450	30	2 950	2 300	1 750	1 300
32	2 350	2 450	1 900	1 350	32	2 500	2 250	1 650	1 200
34	2 000	2 250	1 750	1 250	34	2 150	2 100	1 550	1 100
36	1 700	1 950	1 650	1 150	36	1 800	2 000	1 450	1 000
38	1 400	1 650	1 550	1 050	38	1 500	1 900	1 400	950
40	1 150	1 400	1 350	1 000	40	1 250	1 600	1 300	850
42	950	1 200	1 100	900	42	1 050	1 350	1 250	800
44	750	1 000	900	850	44	800	1 150	1 050	750
46	600	800	750	700	46	600	950	850	700
48	450	650	550	550	48		750	700	650
50		500	400	400	50		600	500	500
52		350			52		450		
54		250			54		300		
56		150			56				

This information is not for crane operation. Operator must refer to the in-cab information for crane operation. Rated lifting capacities shown meet ISO 4305 standards.

8.2t Counterweight – Fully Extended Outriggers – 360° Rotation (All Capacities Are Listed In Kilograms)									
38.71m Main Boom Length 30° Fly Offset					38.71m Main Boom Length 45° Fly Offset				
Radius (m)	Fly Length (m)				Radius (m)	Fly Length (m)			
	11.58	19.51	24.38	29.26		11.58	19.51	24.38	29.26
18	4 050				18				
20	3 950				20	3 650			
22	3 850				22	3 600			
24	3 800	2 200			24	3 500			
26	3 650	2 150	1 650	1 350	26	3 450			
28	3 450	2 100	1 550	1 250	28	3 300	1 900	1 350	
30	3 150	2 050	1 500	1 150	30	3 150	1 850	1 300	1 000
32	2 700	2 000	1 400	1 050	32	2 800	1 850	1 250	950
34	2 300	1 950	1 300	950	34	2 350	1 850	1 200	850
36	1 950	1 850	1 250	900	36	2 000	1 800	1 100	800
38	1 600	1 750	1 200	800	38	1 650	1 700	1 100	750
40	1 350	1 650	1 150	750	40		1 650	1 050	700
42	1 100	1 550	1 100	700	42		1 550	1 000	650
44	850	1 300	1 050	650	44		1 350	1 000	600
46		1 050	1 000	600	46		1 100	950	550
48		850	800	550	48		900	900	500
50		650	650	550	50			700	500
52		500	450	500	52			500	500

This information is not for crane operation. Operator must refer to the in-cab information for crane operation. Rated lifting capacities shown meet ISO 4305 standards.



**This Page Intentionally Blank**

**Link-Belt Construction Equipment Company** Lexington, Kentucky [www.linkbelt.com](http://www.linkbelt.com)

®Link-Belt is a registered trademark. Copyright 2015. We are constantly improving our products and therefore reserve the right to change designs and specifications.