

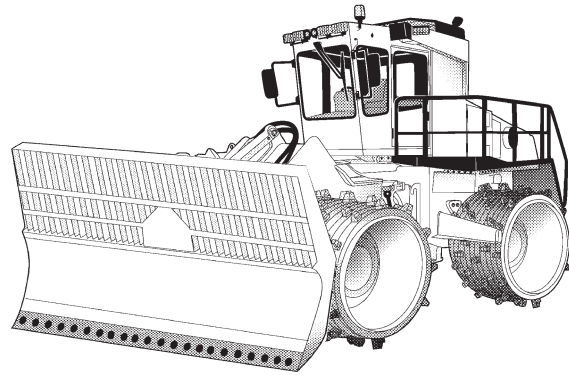

BOMAG
FAYAT GROUP

REFUSE COMPACTOR BC 972 RB-4, BC 1172 RB-4



STANDARD

- Electronic engine management
- Electronic monitoring module with engine shut-down
- Engine air intake at a height of 13 ft
- Dry air filter
- Cold starting system
- Multi fuel filter system
- Fuel bleeding pump
- All wheel drive with hydraulic differential lock
- Wear control in hydraulic circuit
- Hydraulically operated articulated steering system
- Oscillating articulated joint between front and rear frames
- Automatic central lubrication system
- Polygonal compaction wheels
- Adjustable scrapers in front of and behind each wheel
- All drive components well protected by the closed frame pan
- Wire deflector and drive protection on inner side of wheels
- ROPS/FOPS
- Noise insulated cab
- Vibration insulated cab suspension
- Cab ventilation with overpressure
- Activated charcoal filter for odor restriction
- Automatic heating - air conditioning
- Tinted safety glass panes
- Sun shades
- Sliding windows on both sides
- Front I rear windscreen washer system
- Interval switch for windscreen wiper
- Outside and inside rear mirrors
- Heated outside mirror
- Air suspended seat
- Seat heating
- Head rest
- Control unit for dozer blade and travel direction control integrated in driver's seat
- Adjustable joystick steering
- Display instruments
- Radio cassette unit (stereo) AM/FM
- 24 V electrics
- Generator 80 A
- Battery disconnecting switch
- Working lights, 6 front / 4 rear
- Rotary beacon
- Audible backup alarm
- Warning horn
- Access steps right / left
- Towing eyes front / rear
- Hydr. driven, reversible and speed controlled radiator fan
- TELEMATIC
- Reversing monitor

* must be ordered separately

*must be ordered separately

Technical Data

BC 972 RB-4, BC 1172 RB-4

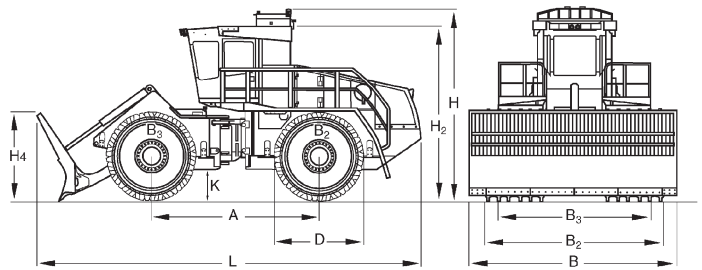

Optional Equipment

- Pre start cabin heating
- Fire extinguisher
- Special painting
- Lockable hood lock (anti-theft protection)
- Semi-U-Blade

Dimensions in inches

	A	B	B ²	B ³	D	H	H ²	H ⁴	K	L
BC 972 RB-4	161	205	177	168	87	191	173	88	30	377
BC 1172 RB-4	161	205	177	168	87	191	173	88	30	377

Technical data

Weights

	BOMAG BC 972 RB-4	BOMAG BC 1172 RB-4
Operating weight CECE lb	106925	123019
Axle load, front / rear CECE lb	50376/55006	59194/63824

Driving Characteristics

	BOMAG BC 972 RB-4	BOMAG BC 1172 RB-4
Speed (1), forward mph	0-1.9	0-1.9
Speed (1), reverse mph	0-1.9	0-1.9
Speed (2), forward mph	0-3.1	0-3.1
Speed (2), reverse mph	0-3.1	0-3.1
Speed (3), forward mph	0-7.5	0-7.5
Speed (3), reverse mph	0-7.5	0-7.5
Max. gradeability (dep. on soil con.) %	100	100
Max. pushing force lbf	112,854	132,187

Drive

	BOMAG BC 972 RB-4	BOMAG BC 1172 RB-4
Engine manufacturer	Merc. Benz/MTU	Merc. Benz/MTU
Type	OM 473 LA	OM 473 LA
Emission stage	Tier 4 Final	Tier 4 Final
Cooling	Liquid	Liquid
Number of cylinders	6	6
Performance ISO 9249 hp	576.6	576.6
Performance SAE J 1349 hp	576.0	576.0
Speed rpm	1700	1700
Travel system	hydrost.	hydrost.
Operating voltage V	24	24

Compaction Wheels

	BOMAG BC 972 RB-4	BOMAG BC 1172 RB-4
Width, front in	55.1	55.1
Width, rear in	55.1	55.1
Number of teeth/cutters, front	72	72
Number of teeth/cutters, rear	72	72
Compaction coverage per side in	59.8	59.8

Brakes

	BOMAG BC 972 RB-4	BOMAG BC 1172 RB-4
Service brake	hydrost.	hydrost.
Parking brake	hydromec.	hydromec.

Steering

	BOMAG BC 972 RB-4	BOMAG BC 1172 RB-4
Steering system	oscil.artic.	oscil.artic.
Steering method	hydraulic	hydraulic
Track radius, inner in	120.1	120.1
Steering / oscillating angle +/- deg	40/15	40/15

Dozer Blade

	BOMAG BC 972 RB-4	BOMAG BC 1172 RB-4
Height adjustment over ground level in	54.1	54.1
Height adjustment below ground level in	2.0	2.0
Dozer blade capacity acc. to SAE J 1265 yd ³	20.7	20.7

Capacities

	BOMAG BC 972 RB-4	BOMAG BC 1172 RB-4
Fuel gal	264.2	264.2
Engine oil gal	12.4	12.4
Hydraulic oil gal	155.9	155.9
AdBlue gal	25.1	25.1

Technical modifications reserved. Machines may be shown with options.