



**BOMAG**  
FAYAT GROUP

# Single Directional Vibratory Plate

## BP25/50



*Removable water tank with level gauge.*



*Easy jobsite movement with transport wheels.*



*Protection for paving stones by the Vulcolan mat.*



# Technical Specifications

## BP25/50

Shipping dimensions  
in cubic feet (m<sup>3</sup>)

BP25/50 15.15 (0.429)

### Standard Equipment

- Honda engine with oil alert
- Vibration isolated engine
- Removable, foldable, vibration isolated steering handle
- Wear resistant base plate with reinforced sides
- Self-cleaning base plate
- Engine protection frame
- Balanced lifting point
- Carrying handles
- Integrated exciter housing
- Centrifugal clutch
- Fully enclosed V-belt

### Optional Equipment

- Water sprinkler system
- Transport wheels
- Vulcolan mat
- Service kit
- Mid mounted handle

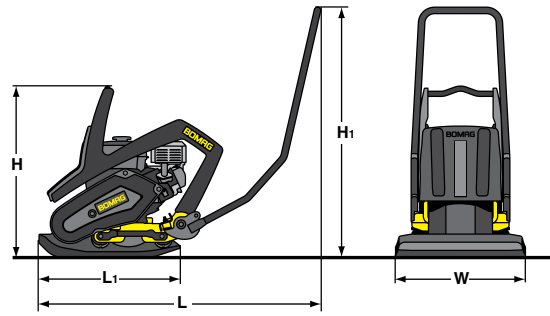

### Dimensions in inches (mm)

	H	H <sub>1</sub>	L	L <sub>1</sub>	W
BP25/50	25.9 (658)	37.9 (962)	42.7 (1084)	21.5 (545)	19.7 (500)

### Technical data

**BOMAG  
BP25/50**

### Weights

Basic weight .....	lbs (kg)	236 (107)
Operating weight .....	lbs (kg)	238 (108)

### Dimensions

Working width.....	in (mm)	19.7 (500)
--------------------	---------	------------

### Driving Characteristics (depending on site conditions)

Max. working speed .....	ft / min (m / min)	98 (30)
Max. gradeability .....	%	30

### Drive

Engine manufacturer.....	Honda	
Type .....	GX160	
Cooling.....	air	
Number of cylinders .....	1	
Performance ISO 9249 .....	hp (kW)	4.8 (3.6)
Speed .....	rpm	3600
Fuel.....	gasoline	

### Vibratory system

Frequency .....	vpm (Hz)	5520 (92)
Centrifugal force .....	lbs (kN)	5620 (25)

### Capacities

Fuel.....	gal (l)	1.0 (3.6)
Water .....	gal (l)	3.6 (13.5)

Technical modifications reserved. Machines may be shown with options.

