



BOMAG
FAYAT GROUP

Reversible Vibratory Plates BPR45/55D, BPR50/55D, BPR60/65D



Fully closed hood for maximum protection and lower repair costs.



BOMAG ECONOMIZER - An optional soil stiffness indicator providing greater productivity and reduced machine wear.



Technical Specifications

Reversible Plates

Shipping dimensions

in cubic feet (m³)

BPR45/55D	44.6	(1.26)
BPR50/55D	44.6	(1.26)
BPR60/65D	44.6	(1.26)

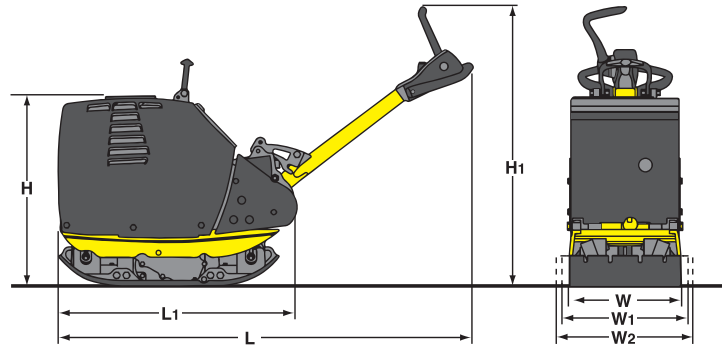

Standard Equipment - All Models

- Fully closed engine protection hood made of high strength steel
- Hydraulic travel lever adjustment
- Low vibration steering rod with four rubber supports
- Height adjustable steering rod
- Steering rod lockable in transport and working position
- Vibration and throttle regulation on the steering rod
- Highly wear resistant base plate with reinforced edges
- Automatically adjusting V-belt pulley
- Fully protected V-belt
- Reinforced centrifugal clutch
- Large-volume dry air filter with cyclone-type precleaner
- Electric start with warning buzzer
- Recoil start with automatic decompression
- Multi-functional, foldable single point lifting facility

Optional Equipment - All Models

- BOMAG Economizer
- Extension plates
- Vulcolan mat
- Hour meter
- Service kit

Dimensions in inches (mm)

	H	H ₁	L	L ₁	W	W ₁	W ₂
BPR45/55D	31.1 (790)	31.5 (800)	66.9 (1700)	35.4 (900)	17.7 (450)	21.7 (550)	29.5 (750)
BPR50/55D	31.1 (790)	38.6 (980)	66.9 (1700)	35.4 (900)	17.7 (450)	21.7 (550)	29.5 (750)
BPR60/65D	31.1 (790)	38.6 (980)	66.9 (1700)	35.4 (900)	17.7 (450)	25.6 (650)	29.5 (750)

Technical Data

Weights

	BOMAG BPR45/55D	BOMAG BPR50/55D	BOMAG BPR60/65D
Basic Operating Weight lbs (kg)	862 (391)	875 (397)	996 (452)
Operating Weight (W) lbs (kg)	840 (381)	851 (386)	961 (436)
Operating Weight (W ₁) lbs (kg)	873 (396)	884 (401)	1005 (456)
Operating Weight (W ₂) lbs (kg)	908 (412)	919 (417)	1030 (467)

Driving Characteristics

	BOMAG BPR45/55D	BOMAG BPR50/55D	BOMAG BPR60/65D
Working speed max ft / min (m /min)	92 (28)	92 (28)	92 (28)
Max. gradeability (depending on soil conditions) %	35	35	35

Drive

	BOMAG BPR45/55D	BOMAG BPR50/55D	BOMAG BPR60/65D
Engine manufacturer	Lombardini	Hatz	Hatz
Type	15 LD 440	1B 40	1B 40
Cooling	air	air	air
Number of cylinders	1	1	1
Performance ISO 9249 hp (kW)	8.9 (6.6)	9.1 (6.8)	9.1 (6.8)
Speed	3000	3000	3000
Drive system	mech.	mech.	mech.
Fuel	diesel	diesel	diesel

Vibratory System

	BOMAG BPR45/55D	BOMAG BPR50/55D	BOMAG BPR60/65D
Frequency vpm (Hz)	4200 (70)	3960 (66)	3960 (66)
Centrifugal force lbs (kN)	10116 (45)	11240(50)	13489 (60)

Capacities

	BOMAG BPR45/55D	BOMAG BPR50/55D	BOMAG BPR60/65D
Fuel gal (l)	1.3 (5)	1.3 (5)	1.3 (5)

Technical modifications reserved. Machines may be shown with options.

