



BOMAG
FAYAT GROUP

Rubber Tire Asphalt Paver **Cedarapids® CR352L**



KEY FEATURES

- 10 ton hopper capacity
- Patented frame-raise system
- Three-point suspension system
- Direct hydrostatic drive
- Unique swinging control console
- Maximum paving width of 20 ft (6.1 m)
- Maximum paving depth of 12 in (305 mm)
- Large tire footprint
- Heavy-duty slat / auger conveyor system
- High alloy cast slat conveyor liners



Technical Specifications

Cedarapids® CR352L

Dimensions in inches (mm)

Clearance	A		B		C
	Screed	Auger Screed Up	Auger Screed Down	Frame	
Frame Raised	14 (356)	7.5 (191)	11 (279)	5.5 (139)	
Frame Lowered	8 (203)	2.5 (64)	5 (127)	6.5 (165)	

Standard Equipment

- Turbocharged 160 hp Tier 3 engine
- Power-tilt hood with radiator
- Lockout/tagout capable E-stop and master electrical switch
- Fume-recovery system
- Accessible filter locations
- All-welded mainframe construction
- Patented Frame Raise and Three-Point Suspension system
- Adjustable spreading auger height
- Reinforced, sealed, tilting hopper wings with beveled corners
- Hydraulically adjustable screed vibrators
- Hydraulic power crown control
- Adjustable material retaining plates
- Dual power-adjustable feed gates
- Oscillating front wheel bogie assemblies
- Hydraulic front wheel alignment
- Hydrostatic steering
- Operator's umbrella
- 30 ft hose reel for spray-down
- Back-up alarm

Mandatory Options (Select only one)

- Two-wheel drive **or** Front wheel assist
- Oscillating push rollers **or** Truck hitch

Optional Equipment

- Stretch® 16 screed with electric or oil heat
- Fastach® 8 screed with electric or oil heat
- Proportional steer assist
- Grade and slope control
- Multi-foot grade reference system
- Sonic averaging systems
- Bevel guide plates
- Cutoff shoes, 12" and 24" sections
- 500-hour filter kit
- Screed extensions
- Up time kit

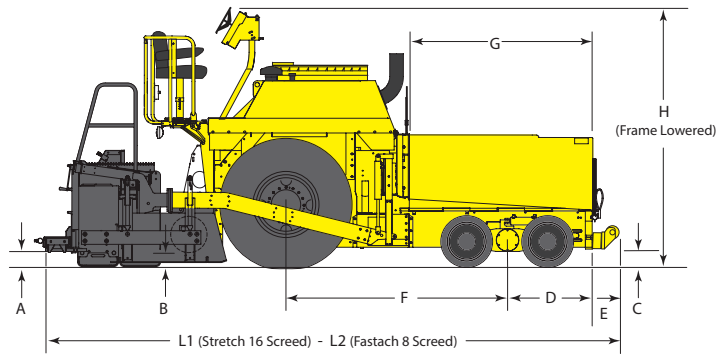

Dimensions in inches (mm)

D	E	F	G	H	L1	L2
34 (864)	10 (254)	83 (2108)	70 (1778)	104 (2642)	231 (5867)	214 (5436)

Technical Data

Paver

Paver width (hopper wings up).....	in (mm)	102 (2590)
Paver width (hopper wings down).....	in (mm)	120.1 (3050)
Paving width (max).....	ft (m)	20 (6.1)
Paving depth (max).....	in (mm)	12 (305)
Paving speed (max).....	ft/min (m/min)	458 (139)
Travel speed (max).....	mph (kmph)	13 (20.9)
Drive tires.....		10-ply 18.4 x 26 in (467 x 660 mm)
Front wheels.....		12 in wide x 22 in dia (305 x 559 mm)
Brakes.....		multiple disc parking

Weights*

Tractor.....	lbs (kg)	25260 (11458)
with Stretch 16 and hydroflated tires.....	lbs (kg)	31870 (14456)
with Fastach® 8 and hydroflated tires.....	lbs (kg)	28760 (13046)

Engine

Make/Model.....	Cummins
Type.....	QSB4.5
Tier compliance.....	Tier 3
Performance.....	hp (kW)
Speed.....	rpm
Electrical.....	V

Capacities

Diesel fuel.....	gal (l)	62 (234)
Hydraulic oil.....	gal (l)	50 (189)
Cooling system.....	gal (l)	6 (23)

Spreading Auger Sections

Construction.....	Cast, high alloy
Diameter.....	in (mm)
Thickness.....	in (mm)

Hopper

Length and width.....	in (mm)	70 (1778) x 118 (2997)
Volume.....	ft ³ (m ³)	165 (4.67)
Capacity.....	tons (tonnes)	10 (9.07)
Feed tunnel width (each).....	in (mm)	25 (635)
Slat conveyor liner (thickness).....	in (mm)	0.375 (9.5)

Screed

Screed plate thickness.....	in (mm)	0.5 (12.7)
Positive crown (hydraulically powered).....	in (mm)	3 (76)
Negative crown (hydraulically powered).....	in (mm)	1 (25)
Vibrations per minute (max).....		3000

Screed Heaters

Stretch® 16 (electric heat) generator.....	kW	20
Stretch® 16 (four oil heaters) 274,000 BTU (total).....	gph (lph)	2.0 (7.6)
Fastach® 8 (electric heat) generator.....	kW	20
Fastach® 8 (two oil heaters) 178,000 BTU (total).....	gph (lph)	1.3 (4.9)

Technical modifications reserved.
Machines may be shown with options.
*Weights are based on average shipping weights.



BOMAG Americas, Inc.
2000 Kentville Rd. • Kewanee, IL 61443
Tel: 309 853-3571 • Fax: 309 852-0350