



HORIZON 6203

The Powerscreen® Horizon Range features horizontal screens that are ideal for handling high volumes of sticky materials and for the exact, fine sizing demanded in many construction contracts.

The Powerscreen® Horizon 6203 excels in applications such as natural and crushed aggregate, coal, iron ore, recycled concrete and asphalt.



✓ APPLICATIONS

AGGREGATE



Sand & gravel
Blasted rock
River rock

RECYCLING



Top soil
C&D waste
Composted materials
Wood by-products
Overburden
Foundry waste

MINING



Processed ores
Processed minerals



TECHNICAL HIGHLIGHTS



INCREASED PRODUCTIVITY

- High capacity up to 800 tph / 881 US tph
- Low engine running speed to improve fuel consumption.
- Rapid set up time - typically under 10 minutes.
- Heavy duty triple shaft horizontal screenbox with adjustable stroke, angle & speed

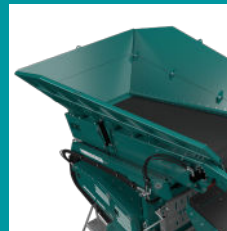

VERSATILITY

- Maximum mobility with heavy duty, low ground pressure crawler tracks
- Removable heavy duty pendant remote control system
- High performance hydraulics system
- Powerscreen Pulse telemetry as standard

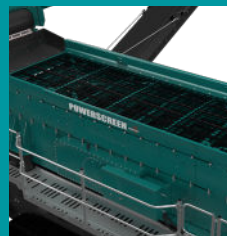

SERVICEABILITY

- Hydraulically folding for transport
- Galvanised maintenance platforms on both sides of screen





TECHNICAL SPECIFICATION

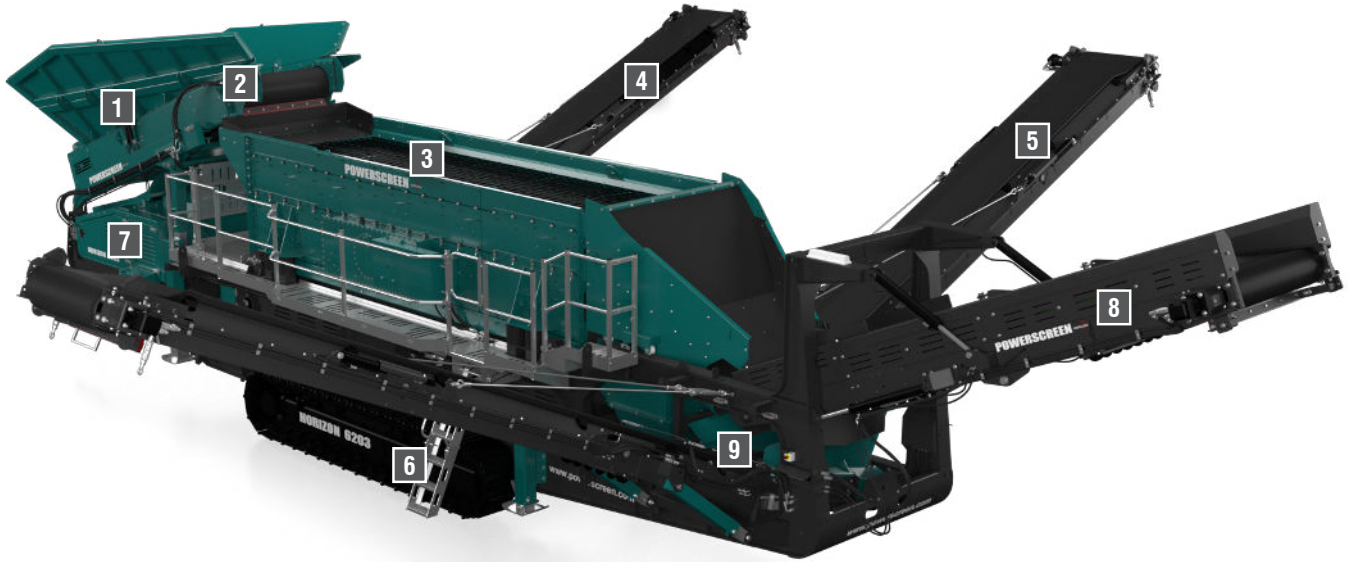

1 HOPPER

Capacity: 8.2m³ (10.72 cu. yd.)
Hydraulic folding hopper sides
Wear resistant steel on hopper sides

2 FEEDER CONVEYOR

Width: 1300mm (52")
Heavy duty belt feeder
Direct drive system with twin direct gearboxes
Variable speed control

3 SCREENBOX

Heavy duty 3 deck screenbox with adjustable screening range
Size: 6.1m x 1.93m (20' x 6' 4")
Oval stroke angle adjustable from 30° - 60°

4 SIDE CONVEYOR (FINESIZE)

Width: 900mm (36")
Discharge height: 4.3m (14' 1")
Variable speed control

5 TAIL CONVEYOR (OVERSIZE)

Width: 1400mm (55")
Discharge height: 4m (13' 1")
Heavy duty impact bars
Variable speed control
Angle adjustable

6 TRACKS

Width: 500mm (1' 8")
2 Speed tracking

7 POWER UNIT

Engine Tier 3 Equivalent: CAT C7.1
151 kW (202hp) @ 2200rpm
Engine Tier 4F / Stage V: CAT C7.1
151 kW (202hp) @ 2200rpm
Fuel tank capacity:
597 L (158 US Gal)

8 SIDE CONVEYOR (MID FINESIZE)

Width: 900mm (36")
Discharge height: 4.4m (14' 5")
Variable speed control

9 UNDERSCREEN CONVEYOR

1500mm (60")
Variable speed control



DIMENSIONS

Working



Transport

Length: 19.54m (64' 1")
Width: 3.24m (10' 8")
Height: 3.6m (11' 10")

Weight

46,700kg (102,956lbs)
*Weights may vary depending on options

GET IN TOUCH

Dungannon

200 Coalisland Road, Dungannon,
Co Tyrone, BT71 4DR, Northern Ireland
Tel: +44 (0) 28 87 718 500
Fax: +44 (0) 28 87 747 231

Louisville

11001 Electron Drive,
Louisville, Kentucky, 40299 USA
Tel: +1 502 736 5200
Fax: +1 502 736 5202



www.powerscreen.com

The material in this document is for information only and is subject to change without notice. Powerscreen assumes no liability resulting from errors or omissions in this document, or from the use of the information contained herein. Due to continual product development we reserve the right to change specifications without notice. Product performance figures given in this brochure are for guidance purposes only, this information does not constitute an expressed or implied warranty or guarantee, but shows test examples provided by Dealers. These results will vary depending on crusher chamber settings, screen media and sizes, feed source and types of material being processed. Photographs are for illustrative purposes only, some or all of the machines in the illustrations may be fitted with optional extras. Please check with your Dealer for details on optional extras. All machines are CE Approved.

Powerscreen® is a registered trademark of Terex GB Limited in the United States of America and many other countries. Copyright 2024 Terex GB Limited. Published and Printed in 2024.